

Model #SJT100-1

1 HP Shallow Well Jet Pump C/W Pressure Tank

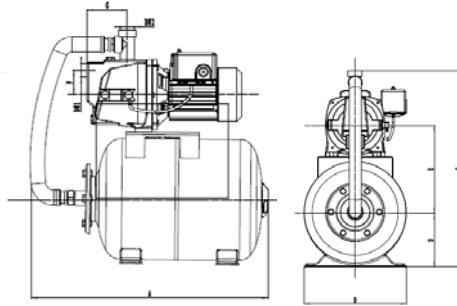

Features & Benefits:

- ❖ For use on shallow well applications up to 25ft water level.
- ❖ Durable cast iron pump housing.
- ❖ Built-in thermal overload protection.
- ❖ Fully automatic water supply.
- ❖ Dedicated priming port for volute filling.
- ❖ 1 ¼" NPT suction and 1" NPT discharge.
- ❖ Complete with 6 gallon tank.
- ❖ 2 year warranty.

Inlet	NPT1
Discharge	NPT1
Pump Cover	/
Motor Housing	ZL102
Pump Body	HT200
Switch Type	Press switch
Impeller	PPO-GF30
Seal Design	Mechanical seal
Seal Material	Graphite & Ceramic
Oil Filled Motor	No
Power Cord	
Net Weight	
Gross Weight	
Package Size	197*118*205
Expected Life Cycle	ON 2 SEC OFF 2 sec. 300,000 cycles
Motor Wires	Copper
Self-Priming	No
Certification	CSA

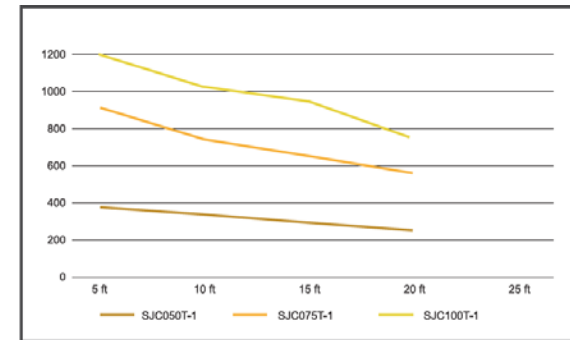

Model	HP	Voltage	AMP	Discharge NPT(In)	GPH of water @ Total Ft. of Head					Max.Head Ft
					5 ft	10 ft	15 ft	20 ft	25 ft	
SJT100-1	1	115 or 230	4.8/9.6	1	1200	1080	960	780		180