

**Model #SEC075T**

**3/4 HP Cast Iron Sewage Pump**

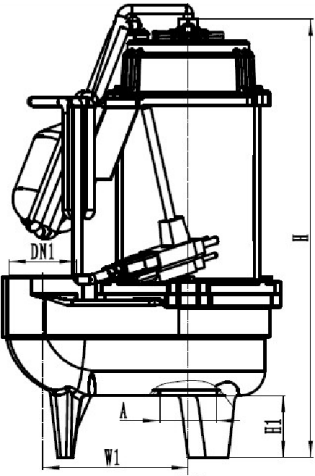

Inlet	2 inch
Discharge	NPT2
Pump Cover	HT200
Motor Housing	08F
Pump Body	HT200
Switch Type	Float switch
Impeller	PA6-GF25
Seal Design	Mechanical seal
Seal Material	Carborundum & Carborundum
Oil Filled Motor	Yes
Power Cord	SJTW3*18AWG
Net Weight	32
Gross Weight	34
Package Size	11.2*7.5*17.1
Expected Life Cycle	ON 10 Sec. OFF 30 Sec. 100,000 cycles
Motor Wires	Copper
Self-Priming	No
Certification	CSA

- Features & Benefits:**
- ❖ Durable cast iron construction.
  - ❖ Heavy duty cast iron volute and nylon impeller.
  - ❖ Built-in automatic thermal overload protector motor.
  - ❖ Adjustable tethered float switch for automatic operation.
  - ❖ Application up to 2" diameter solids.
  - ❖ 2" NPT discharge.
  - ❖ 10ft power cord.
  - ❖ 2 year warranty.

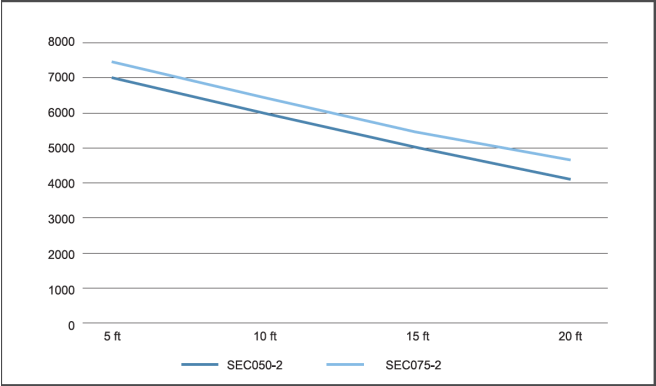

Model	HP	Voltage	AMP	Discharge NPT(In)	GPH of water @ Total Ft. of Head					Max.Head Ft
					5 ft	10 ft	15 ft	20 ft	25 ft	
<b>SEC075T</b>	3/4	120	9.5	2	7500	6400	5400	4600	3700	31