

REPLACEMENT PARTS

Illustrated Parts List

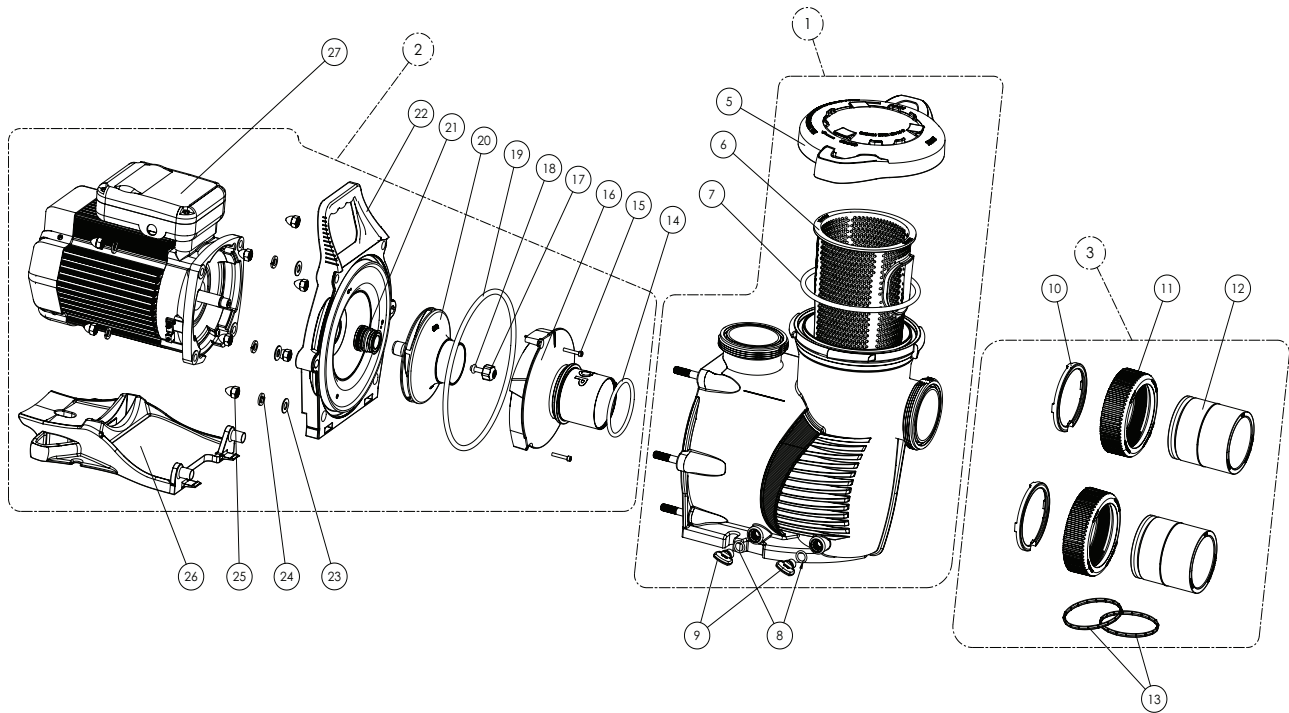

Item No.	Description	WhisperFlo XF	Max-E-Pro XF
1	Wet End Assembly	400000	401000
2	Power End Assembly	See Power End Table	
3	Union Kit Without Tap	410020	410020
5	Lid/Locking Ring Assembly	400006	401006
6	XF Series Replacement Basket	400007z	400007z
7	Lid/Locking Ring O-Ring	35505-1440	35505-1440
8	Drain Plug O-Ring	192115	192115
9	Drain Plug	071131	357161
10	2.5" C-Clip Locking Ring	410001	410001
11	2.5" Union Adapter without Tap	410002	410002
12	2.5" Union Nut	411000	411000
13	2.5" Diamond Seal Kit - (Includes two)	410016z	410016z
14	Diffuser O-Ring	350336	350336
15	Diffuser Screw	353323	353323
16	Diffuser	See Hydraulic Parts Table	
17	Impeller Reverse Screw	37337-6080	37337-6080
18	Impeller Reverse Screw O-Ring	33455-1047	33455-1047
19	Seal Plate O-Ring	351446	351446
20	Impeller Assembly	See Hydraulic Parts Table	
21	Mechanical Seal Assembly	17351-0101S	17351-0101S
22	Seal Plate	400002	401002
22	Seal Plate Kit With Mech Seal	400031z	400032z
23	Flat Washer	072184	072184
24	Split Lock Washer	U43-12SS	U43-12SS
25	Acorn Nut	071413	071413
Not Shown	Hardware and Orings Kit	400030z	400030z
26	Motor Base	400004z	401004z
Not Shown	Riser Plate XF to Challenger	400012	400012
27	Motor	See Motor Table	

Motor Table

Model Name			Motor Part #		Power End Part #	
WhisperFloXF	Max-E-ProXF	Description	WhisperFloXF	Max-E-ProXF	WhisperFloXF	Max-E-ProXF
XFK-8	XPK-8	2hp 3-Phase TEFC 208-230-460V	354809s	354810s	400617z	401617z
XFK-12	XPK-12	3hp 3-Phase TEFC 208-230-460V	354811s	354812s	400618z	401618z
XFK-20	XPK-20	5hp 3-Phase TEFC 208-230-460V	354813s	354814s	400619z	401619z

Hydraulic Parts Table

Model Name			Hydraulic Parts	
WhisperFloXF	Max-E-ProXF	Description	Diffuser	Impeller
XFK-8	XPK-8	2hp 3-Phase TEFC 208-230-460V	400010	400020Z
XFK-12	XPK-12	3hp 3-Phase TEFC 208-230-460V	400010	400015
XFK-20	XPK-20	5hp 3-Phase TEFC 208-230-460V	400011Z	400023Z

Pump Dimensions

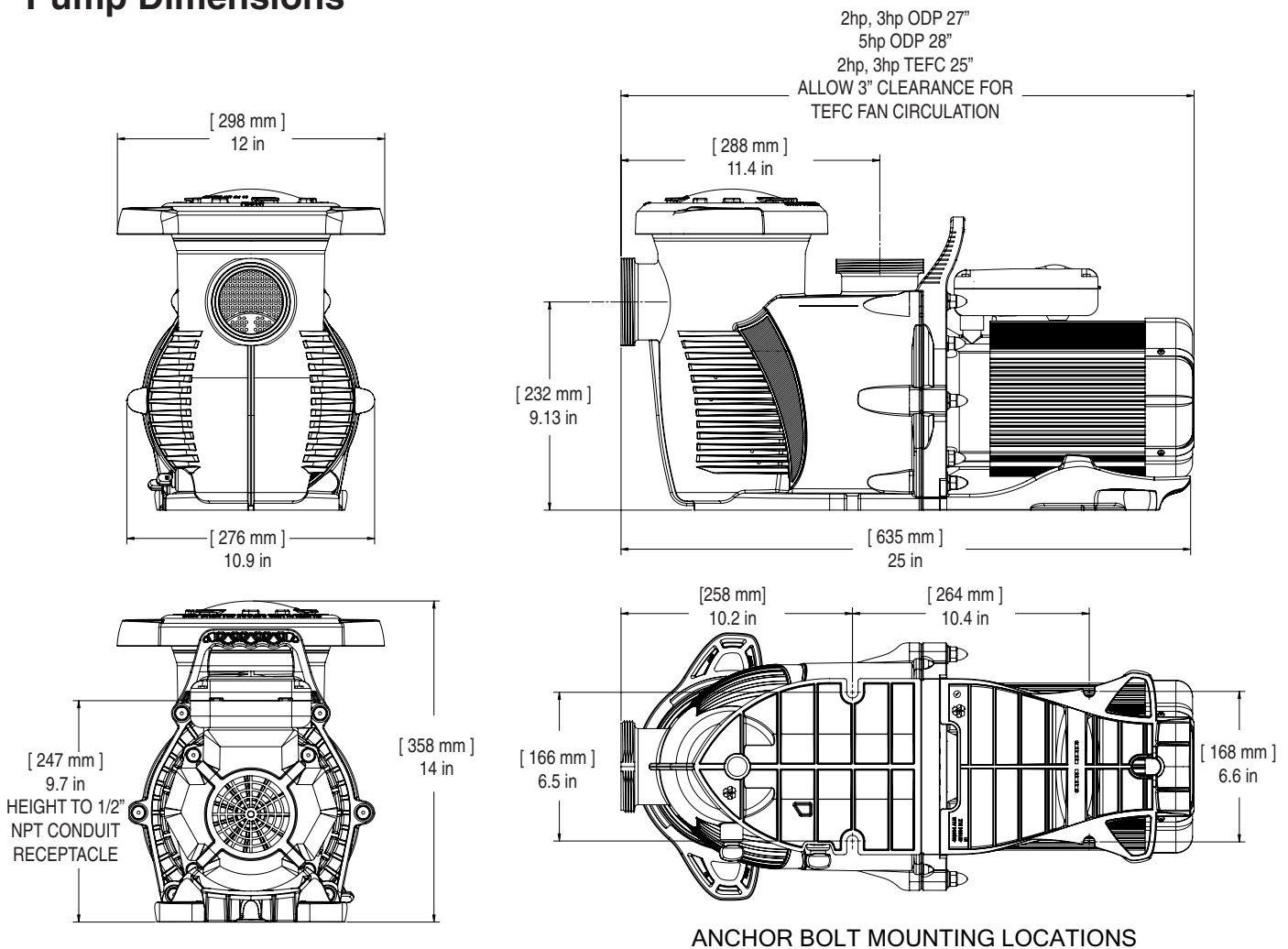

Pump Performance Curves

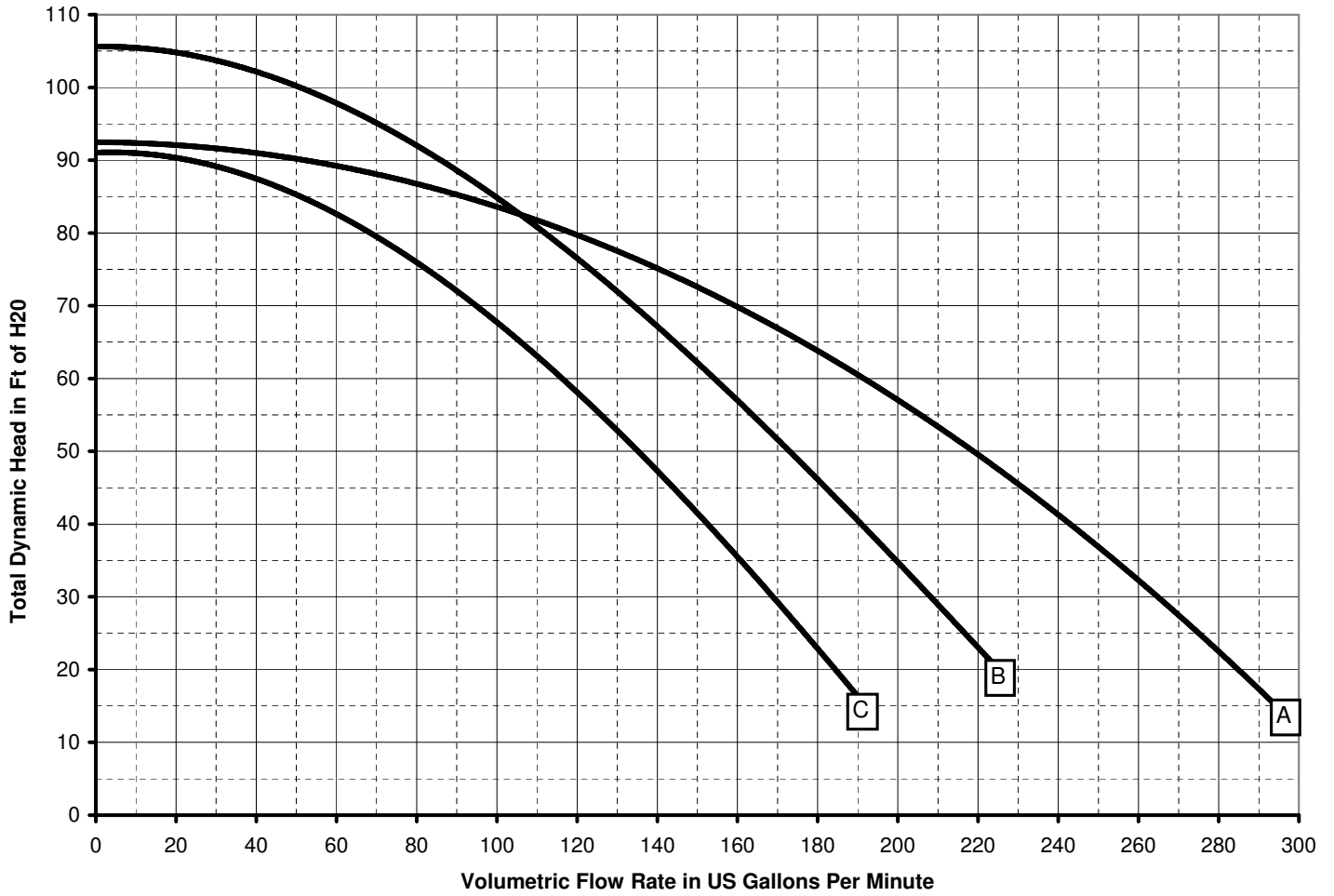

Pump Model	Performance Curve
XFK-8	C
XPK-8	C
XFK-12	B
XPK-12	B
XFK-20	A
XPK-20	A