

CHALLENGER® HIGH FLOW PUMP

REPLACEMENT PARTS

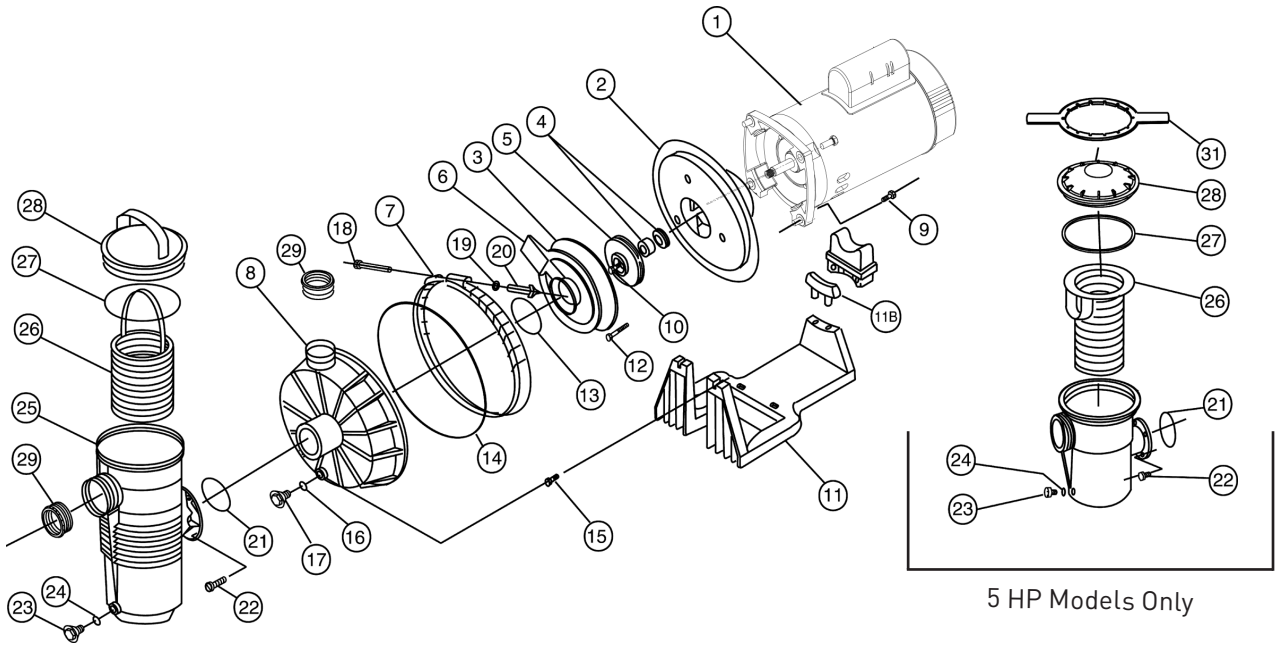

5 HP Models Only

Item	Part No.	Description
CHALLENGER HIGH FLOW PUMP MOTORS		
1	355019S	1/2F, 3/4A std. sq. flg., 115/208-230
1	355021S	3/4F, 1A std. sq. flg., 115/208-230
1	355023S	1F, 1-1/2A std. sq. flg., 115/208-230
1	355025S	1-1/2F, 2A std. sq. flg., 115/208-230
1	355027S	2F, 2-1/2A std. sq. flg., 208-230
1	355034S	3F std. sq. flg. 230 only
1	355009S	3/4FE, 1AE sq. flg. 115/208-230
1	355011S	1FE, 1-1/2AE sq. flg. 115/208-230
1	355013S	1-1/2FE, 2AE sq. flg. 208-230
1	355015S	2FE, 2-1/2AE sq. flg. 208-230
1	355017S	3FE, 1 ph sq. flg. 208-230
1	353319S	5FE, 1 ph, 5 HP, 208-230
1	355375S	3/4F, 1A std. sq. flg. 2 sp. 115 only, 28 lbs.
1	355232S	3/4F, 1A std. sq. flg. 2 sp. 230 only
1	355376S	1F, 1-1/2A std. sq. flg. 2 sp. 230 only
1	355377S	1-1/2F, 2A std. sq. flg. 2 sp. 230 only
1	355378S	2F, 2-1/2A std. sq. flg. 2 sp. 230 only
1	354806S	1 HP, 3 ph sq. flg. TEFC 208-230/460
1	354808S	1-1/2 HP, 3 ph sq. flg. TEFC 208-230/460
1	354810S	2 HP, 3 ph sq. flg. TEFC 208-230/460

Item	Part No.	Description
1	354812S	3HP, 3 ph sq. flg. TEFC 208-230/460
1	354814S	5HP, 3 ph, TEFC 208-230/460 sq. flg. only
2	355004	Plate, seal - black
3	355028	Plate, mounting 1/2F, 3/4F, 3/4A, 1A
3	355078	Plate, mounting 1F, 1-1/2F, 1-1/2A, 2A
3	355095	Plate, mounting 2F, 2-1/2A
3	355495	Plate, mounting 5F
4	354545S	Seal, 5/8 in. mechanical
5	355043	Impeller, 1/2F, 3/4A
5	355067	Impeller, 3/4F, 1A
5	355074	Impeller, 1F, 1-1/2A
5	355086	Impeller, 1-1/2F, 2A
5	355093	Impeller, 2F, 2-1/2A
5	355068	Impeller, 3F 50 Hz/5F 60 Hz
6	355029	Diffuser, 1/2F, 3/4F, 3/4A, 1A
6	355077	Diffuser, 1F, 1-1/2F, 1-1/2A, 2A
6	355094	Diffuser, 2F, 2-1/2A
6	355069	Diffuser, 3F, 50 Hz/5F 60 Hz
7	355320	Band clamp assembly, complete

CHALLENGER® HIGH FLOW PUMP (CONT'D)

REPLACEMENT PARTS

Item	Part No.	Description
CHALLENGER HIGH FLOW PUMPS		
8	355468	Housing, front, black ⁴
8	355469	Housing, front, almond ⁴
9	U30-74SS	Screw, 3/8-16 x 1 in. SS hex hd cap SS 4 req.
10	355389	Screw, impeller locking
11	355305	Base, pump ¹
11B	355385	Adapter, 5-5/8 in. dia. motor ²
12	355334	Screw, No.8, 32 hex wsh. hd., 3 req.
13	355030	O-ring, diffuser (all except 5 HP)
13	355331	O-ring diffuser, 5 HP only
14	355329	O-ring, front housing
15	355335	Screw, 5/16, 18 x 1/2 in. SS hex hd., 2 req.
16	192115	O-ring, drain plug
17	357161	Plug, 1/4 in. drain
18	152060	Bolt, 5/16, 18 x 4 in. carriage ²
19	072173	Washer, 5/16 in. SS flat
20	174882	Knob (fits clamp w/ removable bolt only)
20	175025	Knob (fits clamp w/ captured T-bolt only)
21	355330	O-ring, strainer pot flange
22	354265	Screw, 5/16, 18 hex wsh. hd., 4 req.
23	357161	Plug, 1/4 in. drain
24	192115	O-ring, drain plug
25	355300	Strainer, pot, black ³
26	355318	Basket, plastic strainer
26	355441	Basket, SS Strainer (3F Only)
26	355901	Basket, SS strainer, 5F
27	350013	O-ring, lid
27	152509	Square ring, 8-1/2 in. (5 HP only)
28	355301	Lid, strainer pot
28	354112	Lid, strainer pot, chemical resistant
28	355902	Lid, strainer pot, 5F, clear
28	355914	Lid, strainer pot, 5F, black, chemical resistant
29	552377	Bushing, reducer 1/2F, 3/4F, 3/4A, 1A, 2 req.
31	154527	Wrench, 8-1/2 in.

Item	Part No.	Description
POWER END ASSEMBLIES (INCLUDES ITEMS 1-6, 9, 12 AND 13)		
	355637	CF-N1-3/4F, 1A std., 115/208-230
	355638	CF-N1-1F, 1-1/2A std., 115/208-230
	355520	CF-N1-1-1/2F, 2A std., 115/208-230
	355984	CF-N1-3/4FE, 1AE 115/208-230
	355639	CF-N1-1-1/2FE, 2AE 208-230
	355986	CF-N1-2FE, 2-1/2AE 208-230
	355640	CF-N2-3/4F, 1A 2 sp. std., 115 only
	355641	CF-N2-1F, 1-1/2A 2 sp. std., 230 only
	355642	CF-N2-1-1/2F, 2A 2 sp. std., 230 only
	355987	CF-N2-2F, 2-1/2A 2 sp. std., 230 only
	345211	CFII-N1-5FE, power end
NOT SHOWN		
	355309	Union kit
	357391	Pot Assembly, Black with SS basket (3F Only) Includes items 23-28
	359507	Pot Assembly, Black with plastic bracket (all models except 3F and 5F) Includes items 23-28.
	401014Z	Motor End Cap and Screw

¹ Pump base (item 11) includes dual radius motor support adapter (item 11B) which fits both 5-5/8 in. & 6-1/2 in. dia. motors.

² Item 18, carriage bolt is a replacement part for old style clamp band assembly (item 7).

³ Includes items 23 & 24.

⁴ Includes items 16 & 17.

Note: Challenger booster pumps consist of 1-20.

Note: Challenger pumps consist of all items except No.15.

Note: When ordering replacement motor, give all information on motor name plate.