

# CHALLENGER® HIGH PRESSURE PUMP

## REPLACEMENT PARTS

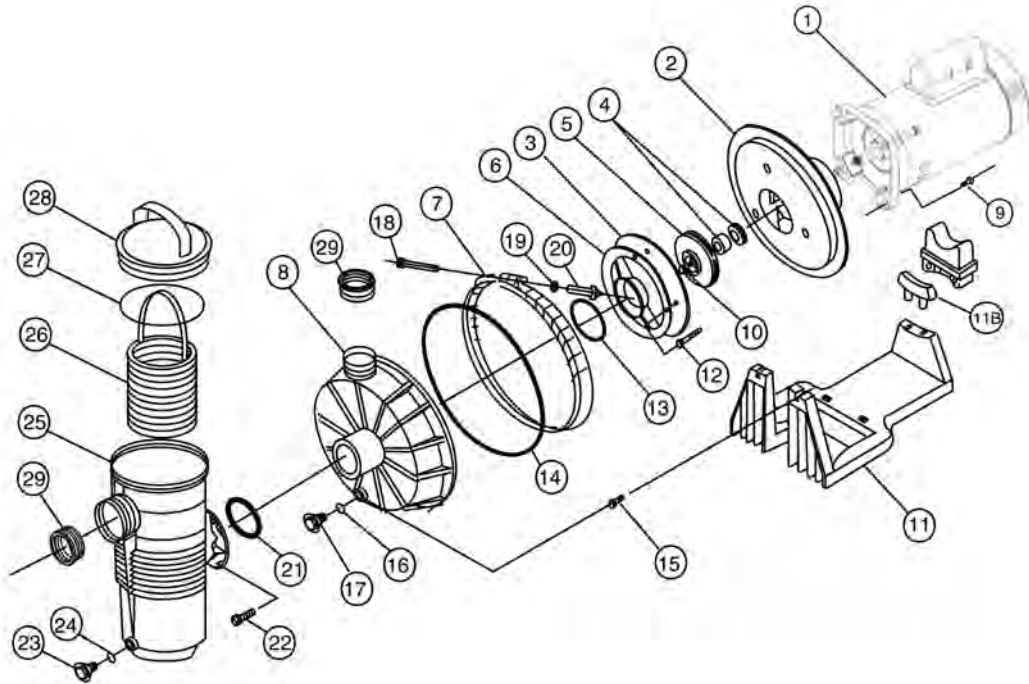

Item	Part No.	Description
<b>CHALLENGER HIGH PRESSURE PUMP MOTORS</b>		
1	355019S	1/2F, 3/4A std. sq. flg., 115/208-230
1	355021S	3/4F, 1A std. sq. flg., 115/208-230
1	355023S	1F, 1-1/2A std. sq. flg., 115/208-230
1	355025S	1-1/2F, 2A std. sq. flg., 115/208-230
1	355027S	2F, 2-1/2A std. sq. flg., 208-230
1	355034S	3F std. sq. flg. 230 only
1	355009S	3/4FE, 1AE sq. flg. 115/208-230
1	355011S	1FE, 1-1/2AE sq. flg. 115/208-230
1	355013S	1-1/2FE, 2AE sq. flg. 208-230
1	355015S	2FE, 2-1/2AE sq. flg. 208-230
1	355017S	3FE, 1 ph sq. flg. 208-230
1	353319S	5FE, 1 ph, 5 HP, 208-230
1	355375S	3/4F, 1A std. sq. flg. 2 sp. 115 only, 28 lbs.
1	355232S	3/4F, 1A std. sq. flg. 2 sp. 230 only
1	355376S	1F, 1-1/2A std. sq. flg. 2 sp. 230 only
1	355377S	1-1/2F, 2A std. sq. flg. 2 sp. 230 only
1	355378S	2F, 2-1/2A std. sq. flg. 2 sp. 230 only
1	354806S	1 HP, 3 ph sq. flg. TEFC 208-230/460
1	354808S	1-1/2 HP, 3 ph sq. flg. TEFC 208-230/460
1	354810S	2 HP, 3 ph sq. flg. TEFC 208-230/460
1	354812S	3HP, 3 ph sq. flg. TEFC 208-230/460
1	354814S	5HP, 3 ph, TEFC 208-230/460 sq. flg. only
2	355004	Plate, seal - black

Item	Part No.	Description
3	355384	Plate, mounting 1/2F, 3/4A
3	355317	Plate, mount 3/4F thru 3F, 1A thru 2-1/2A
4	354545S	Seal, 5/8 in. mechanical PS 200
5	355147	Impeller, 1/2F, 3/4A
5	355187	Impeller, 3/4F, 1A
5	355369	Impeller, 1F, 1-1/2A
5	355315	Impeller, 1-1/2F, 2A
5	355604	Impeller, 2F, 2-1/2A <sup>1</sup>
5	355544	Impeller, 3F
6	355148	Diffuser, 1/2F, 3/4A
6	355188	Diffuser, 3/4F, 1F, 1A, 11/2A
6	355270	Diffuser, 1-1/2F, 2A
6	355545	Diffuser, 3F, 2.5A, 2F <sup>2</sup>
7	355320	Band, clamp assembly complete
8	355468	Housing, front, black
8	355469	Housing, front, almond
9	U30-74SS	Screw, 3/8 in., 16 SS hex hd., 4 req.
10	355389	Screw, imp. locking
11	355305	Base, pump <sup>3</sup>
11B	355385	Adapter, 5-5/8 in. dia. motor <sup>4</sup>
12	355334	Screw, 8-32 x 1 in. SS hex wsh. hd., 3 req.
13	355331	O-ring, diffuser

# CHALLENGER® HIGH PRESSURE PUMP (CONT'D)

## REPLACEMENT PARTS

Item	Part No.	Description
<b>CHALLENGER HIGH PRESSURE PUMPS</b>		
14	355329	O-ring, front housing
15	355335	Screw, 5/16 in., 18 x 1/2 in. SS hex wsh. hd., 2 req.
16	192115	O-ring, drain plug
17	357161	Plug, 1/4 in. drain
18	152060	Bolt, 5/16 in., 18 x 4 in. carriage <sup>5</sup>
19	072173	Washer, 5/16 in. SS flat
20	174882	Knob (fits clamp w/ removable bolt only)
20	175025	Knob (fits clamp w/ captured t-bolt only)
21	355330	O-ring, strainer pot flange
22	354265	Screw, 5/16 in., 18 x 3/4 in. SS hex wsh. hd., 4 req.
23	357161	Plug, 1/4 in. drain
24	192115	O-ring, drain plug
25	355300	Pot strainer
26	355318	Basket, plastic strainer (all except 3F)
26	355441	Basket, SS strainer (3F only)
27	350013	O-ring, lid
28	355301	Lid, strainer pot
28	354112	Lid, strainer pot chemical resistant
29	552377	Bushing, reducer 1/2F, 3/4F, 3/4A, 1A
<b>POWER END ASSEMBLIES (INCLUDES ITEMS 1-6, 9, 10, 12 AND 13)</b>		
	355670	CH-N1-1/2F, 3/4A std. power end 115/208-230
	355671	CH-N1-3/4F, 1A std. power end 115/208-230
	355672	CH-N1-1F, 1-1/2A std. power end 115/208-230
	355669	CH-N1-11/2F, 2A std. power end 115/208-230

Item	Part No.	Description
	355674	CH-N1-1FE, 1-1/2AE power end 115/208-230
	355675	CH-N1-1-1/2FE, 2AE power end 208-230
	355676	CH-N1-2FE, 2-1/2AE power end 208-230 <sup>1</sup>
	355677	CH-N1-3FE, 1 ph power end 208-230
	355679	CH-N2-3/4F, 1A 2 sp. std. power end 115 only
	355680	CH-N2-1F, 1-1/2A 2 sp. std. power end 230 only
	355681	CH-N2-1-1/2F, 2A 2 sp. std. power end 230 only
	355682	CH-N2-2F, 2-1/2A 2 sp. std. power end 230 only
<b>NOT SHOWN</b>		
	355302	Housing booster pump
	355309	Union Kit
	357391	Pot Assembly, Black with SS basket (3F Only) Includes items 23-28
	359507	Pot Assembly, Black with plastic bracket (all models except 3F and 5F) Includes items 23-28.
	401014Z	Motor End Cap and Screw

<sup>1</sup> Used on 2F, 2-1/2A pumps built after 10-1-92.

<sup>2</sup> Used on 2F, 2-1/2A pumps built prior to 10-1-92. Must replace w/ both diffuser 355545 & impeller 355604.

<sup>3</sup> Pump base, (item 11) includes dual radius motor support adapter (item 11B), which fits both 5-5/8 in. & 6-1/2 in. dia. motors.

<sup>4</sup> Item 11A motor support is a replacement part that fits only older style pump bases with rectangular opening.

<sup>5</sup> Carriage bolt (item 18) fits prev. style clamp band assembly (item 7).

Note: Challenger booster pumps consist of items 1-20.

Note: Challenger pool pumps consist of all items except item 15.