

# **Griswold H Series, High Head, Self-Priming Pump**

**Griswold's High Pressure H Series pumps offer performances previously unavailable.**

Ideally suited for applications where relatively clean water is needed at higher pressures.

***Pressures up to 110 PSI  
(260 Feet)  
and flows to 325 GPM...***

**fire protection, marine,  
forestry, irrigation, industrial  
and commercial applications.**

The H Series pumps are designed specifically to lift water (up to a maximum of 25 feet). Unlike standard end suction centrifugal pumps the Griswold H Series is a true self-priming pump. Able to maintain its prime even when check valves or foot valves have failed. The suction line being located higher on the pump housing than conventional centrifugal pumps keeps the impeller and mechanical seal covered with water at all times eliminating the need to re-prime the pump and protects the seal from running dry and costly replacements.

The H Series pumps are available in two versions. The HL pumps are designed for higher pressures at lower flows with lower horsepower. The HH pumps are designed for higher flows at higher pressures requiring higher horsepower.

Both the HL and the HH pumps are available in your choice of drivers. Close-coupled electric motors, long-coupled frame mounted, or close-coupled engine driven with your choice of gas, diesel or LP fueled air cooled engines. Close-coupled, electric driven pumps are available with ODP or TEFC, JM frame motors.

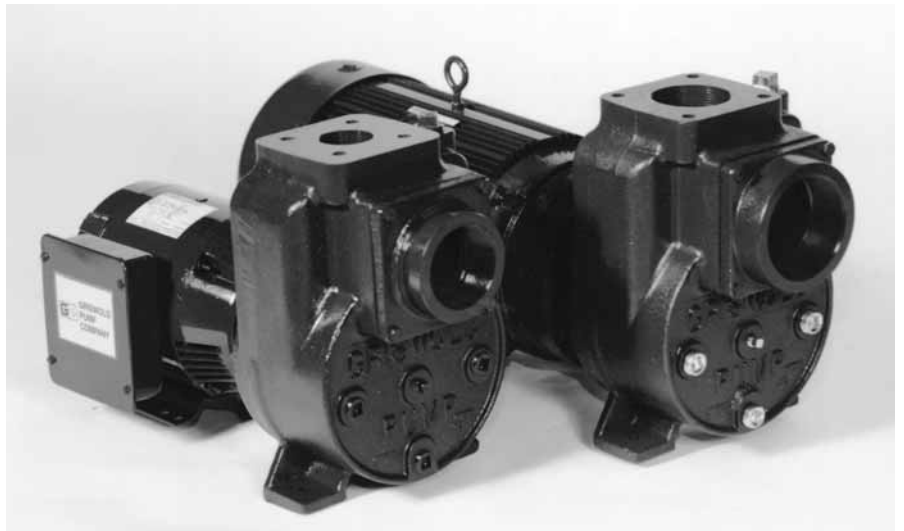

***Pressures up to 110 PSI (260 Feet) and flows to 325 GPM...***

# Griswold H Series, High Head, Self-Priming Pump

## Pump Features

**Casing** - Heavy duty cast iron ASTM A48 class 30 case with built-in drain and priming plugs and bolt-on suction flange. The HL and HH also have (3) 3/4" NPT plugged connections on the case for accessories to be installed or auxiliary water outlets. Extra-large priming chamber for fast, trouble-free priming. The HL and HH series offers dual connections. Both pumps can be connected by either NPT threads or ANSI flanges on the discharge and NPT threads or Victaulic<sup>®</sup> groove connections on the suction.

**Suction Flanges** - Bolt-on suction flange available in a variety of sizes to accommodate your specific flow and horsepower requirements. The 3" flange is machined for both 3" NPTF threads and 3" Victaulic<sup>®</sup> groove connection. The 4" flange is machined for 4" NPTF threads.

**Discharge** - dual connections. Both pumps can be connected by either NPT threads or ANSI flanges.

**JM Frame Motors**  
All Brands. All Phases & Voltages  
60 or 50 Cycle  
ODP. TEFC  
Explosion Proof  
Chem Duty  
IEEE45 Marine Duty  
Inverter Duty  
**OR**  
**Frame Mounted**  
**OR**  
**Engine Driven**  
Gas, Diesel or LP

The suction line being located higher on the pump housing than conventional centrifugal pumps keeps the impeller and mechanical seal covered with water at all times eliminating the need to re-prime the pump and protects the seal from running dry and costly replacements.

**Built-In Check Valve** - Prevents siphoning and need for repriming. No external check valve is required. Designed for easy replacement.

**1" NPT Priming Plug**  
(Not Shown)

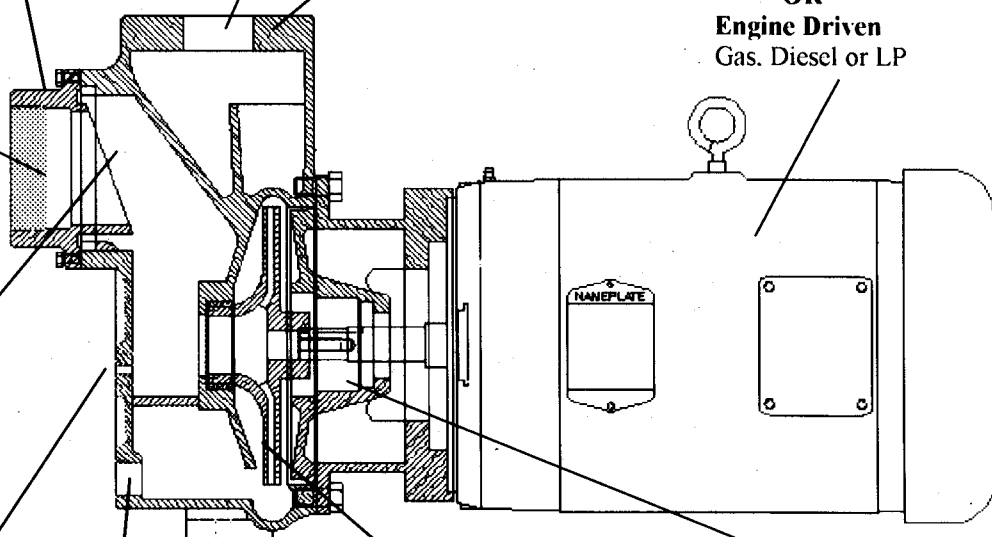

**1/4" NPT Tapping (Vacuum)**

**(3) 3/4" NPT Accessory Tappings (Pressure)**

**Enclosed Impeller** - Bronze, single piece design, balanced and trimmed for a specific operating range.

**Choice of Seals** - Carbon and ceramic faces, plus stainless steel components eliminate maintenance problems. Other seal options are available.

# Griswold H Series, High Head, Self-Priming Pump

## Performance

### HL SERIES 3470 RPM

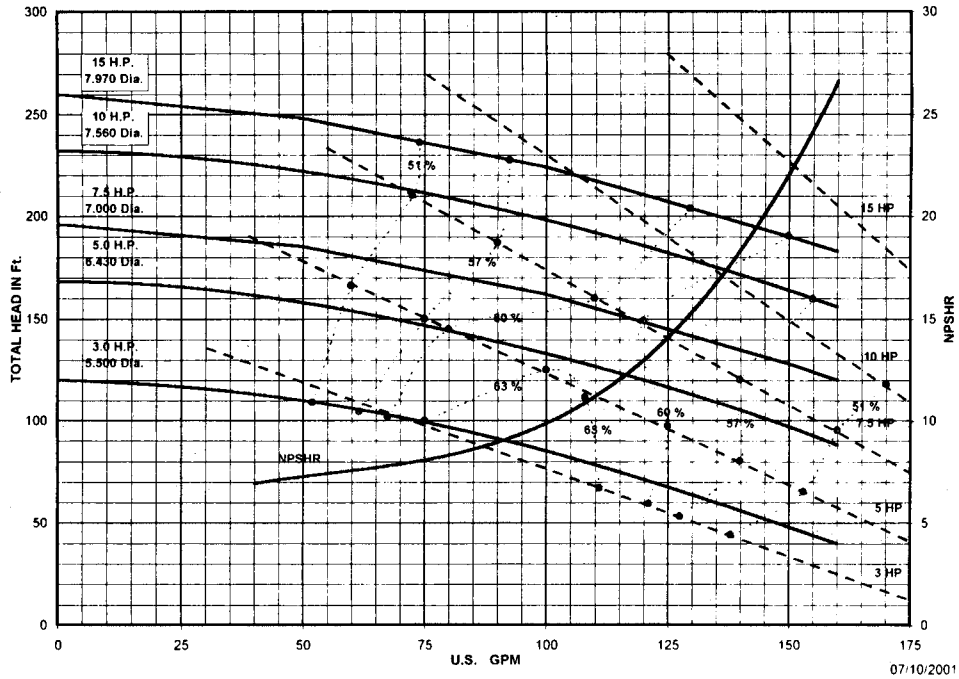

### HH SERIES 3470 RPM

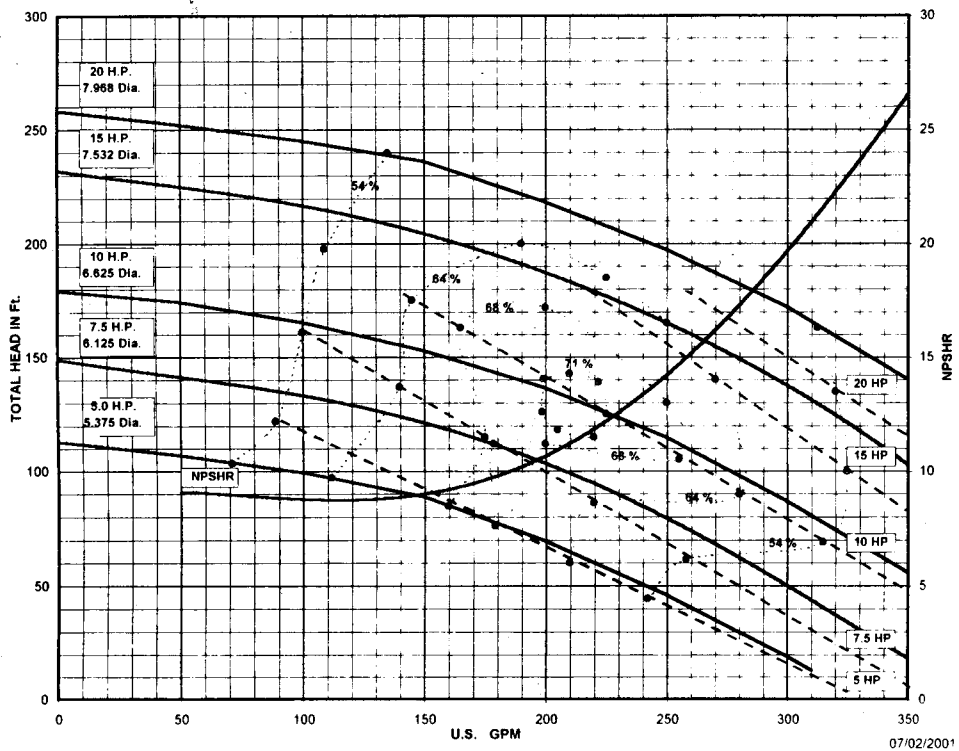

# Griswold H Series, High Head, Self-Priming Pump

## Dimensions

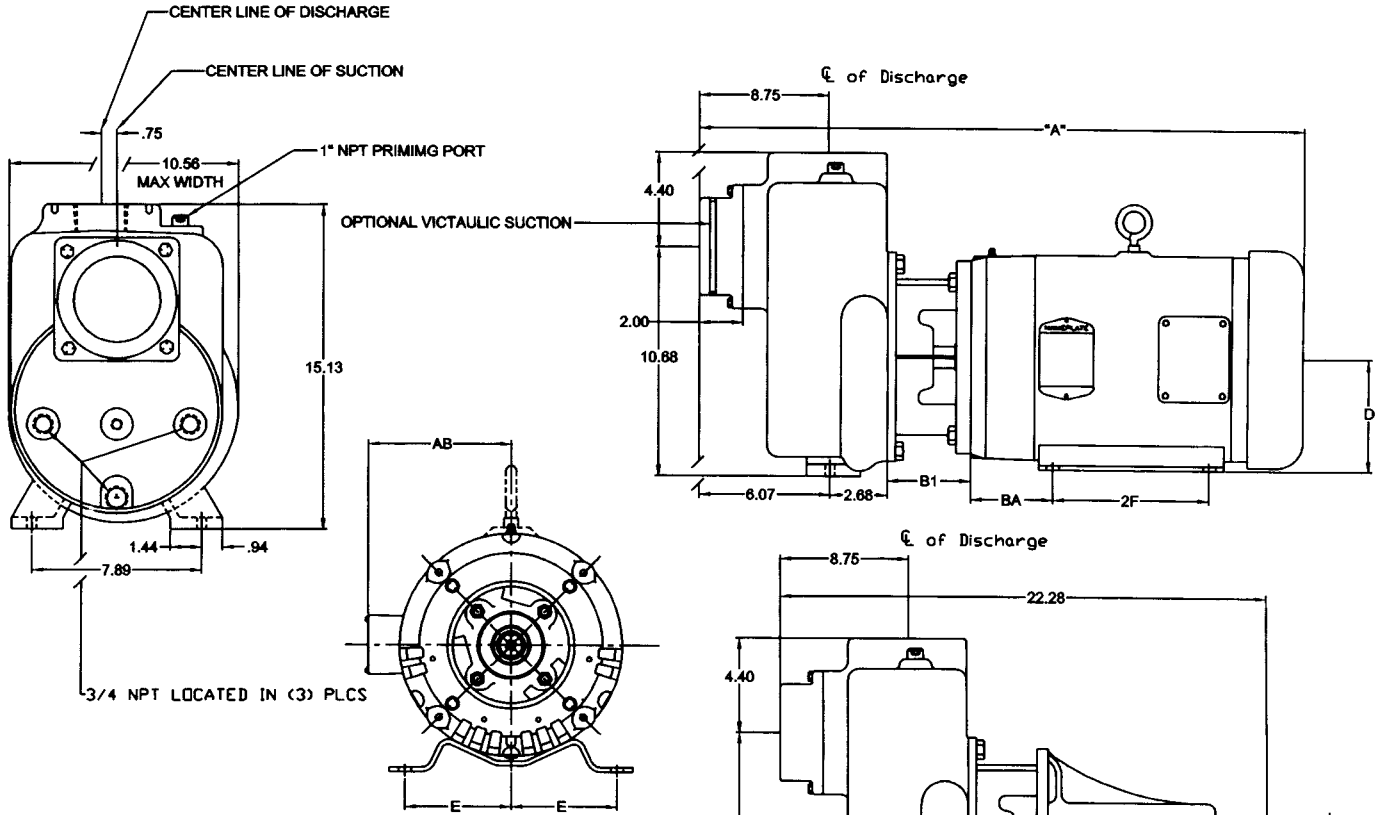

Note:  
Discharge is flanged & threaded.

Pump Size	Suction	Disch.						
HL	3" NPT	2" NPT / 2" 125# FLG						
HH	4" NPT	3" NPT / 3" 125# FLG						
Single Phase DripProof								
	Frame	A	AB	B1	BA	2F	D	E
3HP	182JM	21.025	8.08	2.875	2.75	4.5	4.5	3.75
5HP	184JM	23.535	8.08	2.875	2.75	4.5	4.5	3.75
7.5HP	213JM	25.655	9.31	2.875	3.5	5.5	5.25	4.25
10HP	215JM	27.155	9.31	2.875	3.5	7	5.25	4.25
Three Phase DripProof								
3HP	145JM	21.025	7.04	2.875	2.25	5	3.5	2.75
5HP	182JM	22.965	8.08	2.875	2.75	4.5	4.5	3.75
7.5HP	184JM	23.535	8.08	2.875	2.75	4.5	4.5	3.75
10HP	213JM	25.655	9.31	2.875	3.5	5.5	5.25	4.25
15HP	215JM	27.155	9.31	2.875	3.5	7	5.25	4.25
20HP	254JM	29.515	10.96	3.625	4.25	8.25	7	5
Three Phase TEFC								
5HP	184JM	30.80	8.08	2.875	2.75	5.5	4.5	3.75
7.5HP	184JM	30.80	8.08	2.875	2.75	4.5	4.5	3.75
10HP	215JM	35.21	9.31	2.875	3.5	7	5.25	4.25
15HP	215JM	35.21	9.31	2.875	3.5	7	5.25	4.25
20HP	256JM	41.93	10.96	3.625	4.25	10	7	5



22069 Van Buren Street • Grand Terrace, CA 92313-5607  
 Phone: (229) 226-5255 • (800) 843-9222  
 Fax (229) 226-5567 • (909) 422-1787  
 email: [griswold@griswoldpump.com](mailto:griswold@griswoldpump.com)  
 website: [www.griswoldpump.com](http://www.griswoldpump.com)



Your Distributor: