

# DYNA-JET™ SERIES PUMP

## TPE SERIES REPLACEMENT PARTS

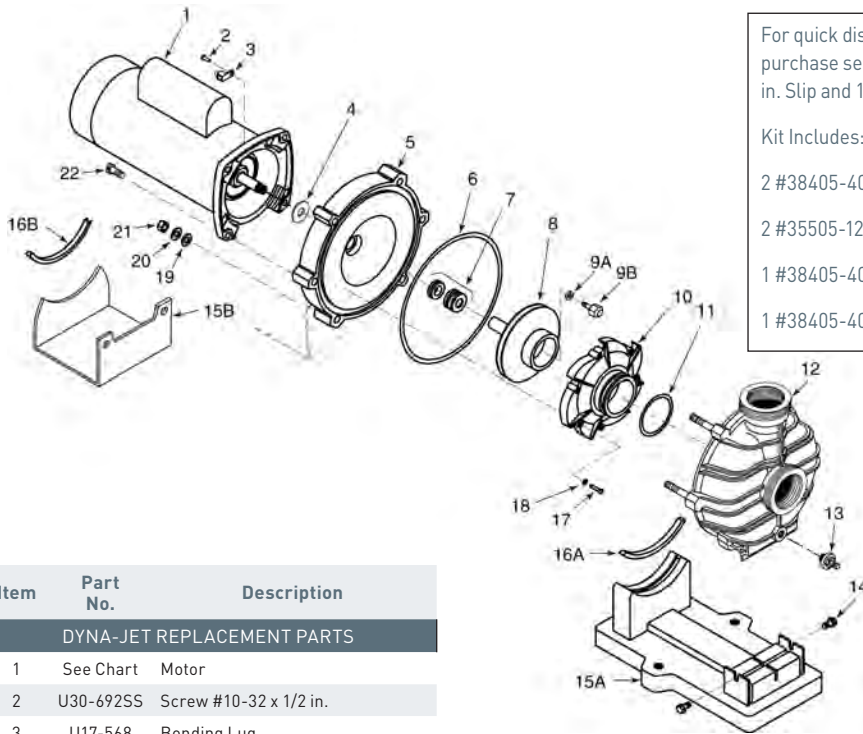

For quick disconnect pipe connections, purchase separately Part No. 77703-0105 (2 in. Slip and 1-1/2 in. Slip Union Kit).

Kit Includes:

2 #38405-4094 Union Collars

2 #35505-1244 O-Ring

1 #38405-4095 2 in. Slip Adapter

1 #38405-4096 1-1/2 in. Slip Adapter

Item	Part No.	Description
<b>DYNA-JET REPLACEMENT PARTS</b>		
1	See Chart	Motor
2	U30-692SS	Screw #10-32 x 1/2 in.
3	U17-568	Bonding Lug
4	17351-0009	Slinger <sup>4</sup>
5	C3-184P	Seal Plate
6	U9-373	Seal Plate Cord Ring
7	17351-0101S	Shaft Seal
8	See Chart	Impeller
9A	33455-1047	Impeller Lock Screw Gasket <sup>1</sup>
9B	37337-6080	Impeller Lock Screw <sup>1</sup>
10	C1-270P	Diffuser <sup>2</sup>
11	U9-374	Diffuser O-Ring
11	357098Z	Diffuser O-Ring (Blue Coating)
12	17303-0001	Pump Body (Only)
13	U178-920P	Drain Plug
14	U30-919SS	Hi-Lo Screw 5/16-14 x 5/8 in.
15A	C4-77P	Base - Corrosion Resistant
15B	17303-0113	Base - Steel <sup>3</sup>
16A	C35-45	Motor Pad - for Corrosion Resistant Base
16B	C35-5	Motor Pad - for Steel Base <sup>3</sup>
17	U30-542SS	Screw #8-32 x 7/8 in. Rd. Hd.
18	U43-21SS	Lock Washer #8 Ext. Tooth
19	U43-62SS	Flat Washer 3/8 in.
20	U43-12SS	Lock Washer 3/8 in.
21	071403	Nut 3/8-16 Hex
22	U30-74SS	Cap Screws 3/8-16 x 1 in. Hex.
<b>NOT SHOWN</b>		
	U9-359	Drain Plug O-Ring

Parts are common to all models except as noted: Key Nos. 1, Motor; and 8, Impeller, are listed below.

Model No.	HP	Motor No. (Key No. 1)	Impeller (Key No. 8)
115/230/60/1			
TPEAE-165L	1	62003-2025	C105-236PB
TPEAF-166L	1-1/2	AE100FLL	C105-236PC
TPRAF-174L	1-1/2	A100FLL	C105-236PF
230/60/1			
TPEAG-167LS	2	AE100GLL	C105-236PDA
TPRAG-175L	2	A100GLL	C105-236PGA
TPEAAG-168LS	2-1/2	AE100G5LL	C105-236PEA
230/60/1 (2 Speed)			
TPRAYF-174S	1-1/2	A100FLL-Y	C105-236PF
TPEAYG-175L	2	AE100GLL-Y	C105-236PGAB
TPEAYG-175LS	2	AE100GLL-Y	C105-236PGAB
TPEAYG-167LS	2	AE100GLL-Y	C105-236PDA
TPEAAYG-168L	2-1/2	AE100G5LL-Y	C105-236PHA
TPEAAYG-168LS	2-1/2	AE100G5LL-Y	C105-236PHA

<sup>1</sup> Models TPEAG-167L, TPEAAG-168L, and TPRAG-167L only.

<sup>2</sup> Model TPEAE-165L and TPRAE3-165 use Part No. C1-270PC.

<sup>3</sup> Models with LS suffix only.

<sup>4</sup> Replaces C69-24 (effective 9/00).