

REPLACEMENT PARTS

230 VOLT/ 1 PHASE OR 230/460 VOLT/3 PHASE

Item No.	Part No.	Description
1	S22351	Motor 230V/1 Ph. - 7-1/2 HP (Models: CSPHK-142 ¹ , CCSPHK-142 ¹ , CSPHK3-142 ² , CCSPHK3-142 ²)
1	62500-0101	Motor 230V/1 Ph. - 10 HP (Models: CSPHL-143, CCSPHL-143M, CSPHL3-143 ¹ , CCSPHL3-143 ¹) Motor 230V/1 Ph. - 10 HP (Models: CSPHL-143, CCSPHL-143M, CSPHL3-1431
1	S22353	Motor 230V/3 Ph. - 7-1/2 HP (Models: CSPHK-142 ¹ , CCSPHK-142 ¹ , CSPHK3-142 ² , CCSPHK3-142 ²)
1	S22356	Motor 230V/3 Ph. - 10 HP (Models: CSPHL-143, CCSPHL-143M, CSPHL3-143 ¹ , CCSPHL3-143 ¹)
1	S22357	Motor 230V/3 Ph. - 15 HP (Models: CSPHM3-144 ¹ , CCSPHM3-144 ¹)
1	S28574	Motor 230V/3 Ph. - 20 HP (Models: CSPHN3-145 ¹ , CCSPHN3-145 ¹) Motor 230V/3 Ph. - 20 HP (Models: CSPHN3-1451, CCSPHN3-1451)
1	16830-0320	Motor 230V/3 Ph. 7-1/2 HP (Models: CSPH2K3-142, CSPH2K3-142)
1	16831-0320	Motor 230V/3 Ph. - 10 HP (Models: CSPH2L3-143, CCSPH2L3-143)
1	16832-0320	Motor 230V/3 Ph. - 15 HP (Models: CSPH2M3-144, CCSPH2M3-144)
1	16833-0320	Motor 230V/3 Ph. - 20 HP (Models: CSPH2N3-145, CCSPH2N3-145)
2	S23488	Nut, 1/2"
3	U43-13SS	Lockwasher, 1/2"
3	U43-12SS	Lockwasher, 3/8" ²
4	L05329	Bracket - 7-1/2 HP (CSPH, CSPH2 Models)
4	L05328	Bracket - 10 HP (CSPH, CSPH2 Models) 15 HP (CSPH, CSPH2 Models)
4	L05779	Bracket - 20 HP (CSPH, CSPH2 Models)
4	16830-2201	Bracket - 7-1/2 HP (CCSPH, CCSPH2 Models)
4	16830-2203	Bracket - 10 HP (CCSPH, CCSPH2 Models) 15 HP (CCSPH, CCSPH2 Models)
4	16830-2202	Bracket - 20 HP (CCSPH, CCSPH2 Models)
5	30747-0152	Stud, 1/2 - 13 x 1-1/2"
6	S32014	Mechanical Shaft Seal
6	S32015	Mechanical Shaft Seal - 20 HP
7	S11207	Retaining Ring
7	S16767	Retaining Ring - 20 HP (Models: CSPHN3-145 ¹ , CCSPHN3-145 ¹)
8	37447-0001	Shaft Sleeve
8	37447-0002	Shaft Sleeve - 20 HP
9	S04757	Gasket (Volute to Bracket)
10	33455-8044	Gasket (Impeller to Shaft Sleeve)
10	33455-8046	Gasket (Impeller to Shaft Sleeve) - 20 HP
11	16830-0209	Impeller - 7-1/2 HP
11	16830-0210	Impeller - 10 HP
11	16830-0211	Impeller - 15 HP
11	16830-0212	Impeller - 20 HP
12	33455-8043	Gasket (Impeller to Washer)
12	33455-8045	Gasket (Impeller to Washer) - 20 HP
13	38917-0203	Impeller Washer
13	38917-0204	Impeller Washer - 20 HP (Models: CSPHN3-145 ¹ , CCSPHN3-145 ¹)
14	C43-46SS	Stat-O-Seal Washer
14	C43-46SSA	Stat-O-Seal Washer - 20 HP (Models: CSPHN3-145 ¹ , CCSPHN3-145 ¹)
15	S23566	Capscrew, 3/8-16x1" ¹
15	S23619	Capscrew, 1/2-13x1" ²
16	U78-57DT	Pipe Plug, 1/4 in. NPT
17	16830-0400	Hardware Kit
18	33450-8042	Gasket (Volute Discharge)
19	33450-8041	Gasket (Volute Suction)

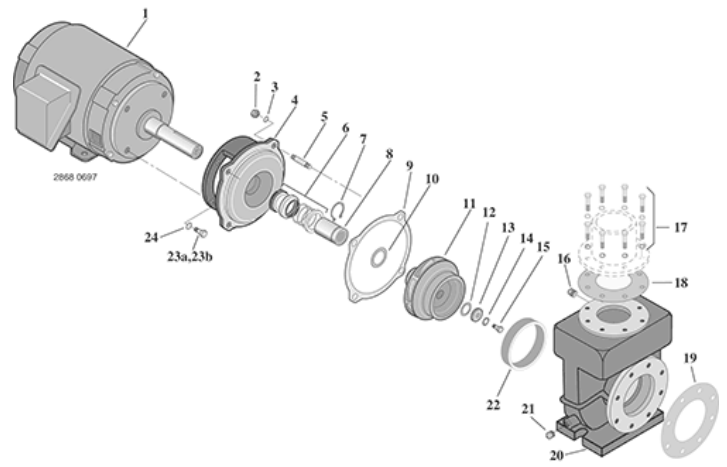
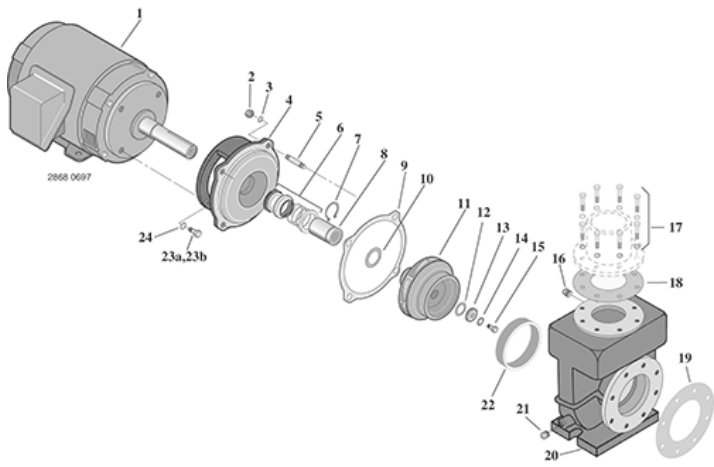

REPLACEMENT PARTS

230 VOLT/ 1 PHASE OR 230/460 VOLT/3 PHASE

Item No.	Part No.	Description
20	16830-0100	Volute (CSPH, CSPH2)
20	16830-2102	Volute (CCSPH) - 7-1/2 HP, 10 HP
20	16830-2103	Volute (CCSPH) - 15 HP, 20 HP ¹
20	16830-0100	Volute (CSPH, CSPH2)
20	16830-2102	Volute (CCSPH) - 7-1/2 HP, 10 HP
21	U78-59D	Drain Plug, 1/2" NPT
22	16830-0120	Wear Ring
23A	S23619	Capscrew, 1/2-13x1" ¹
23B	S23566	Capscrew, 3/8-16x1" ²
24	U43-13SS	Lockwasher, 1/2"

1: 7-1/2 HP; 1 Phase only.

2: 3 Phase only