

# Sectional drawing, SP pump 10" (SP 625S - 1100S)

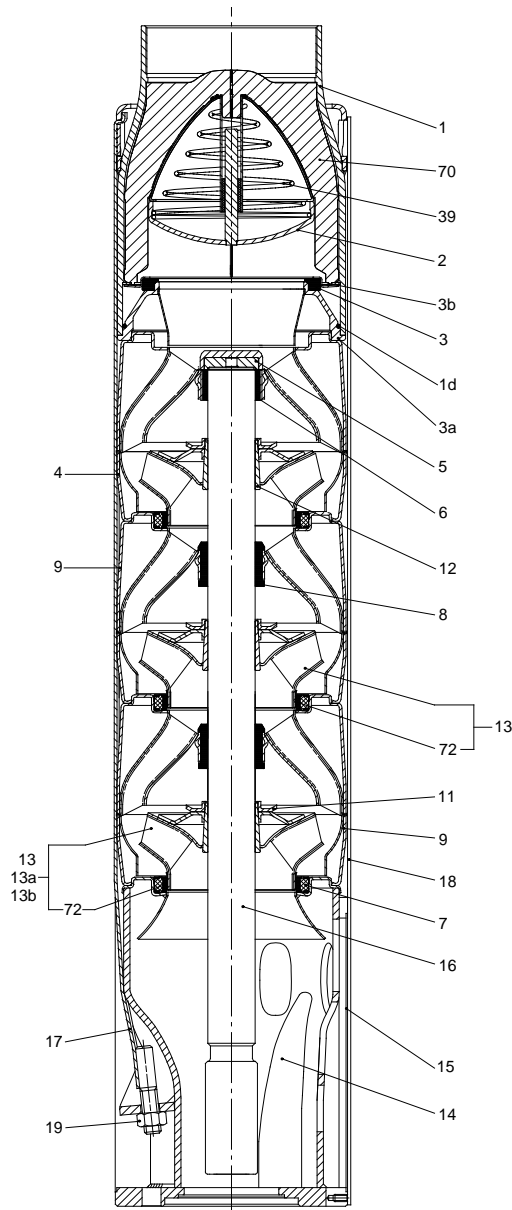

Fig. 17 SP pump, 10" (SP 625S - 1100S)

TM01 2363 2701

## Material specification

Pos.	Description	Material	Standard	N
			[AISI (EN)]	
<b>Valve casing</b>				
1	Valve casing	Stainless steel	304 (1.4301)	316 (1.4401)
1d	O-ring	NBR		
2	Valve cup	Stainless steel	304 (1.4301)	316 (1.4401)
3	Valve seat	Stainless steel	304 (1.4301)	316 (1.4401)
3a	Lower valve seat retainer	Stainless steel	304 (1.4301)	316 (1.4401)
3b	Upper valve seat retainer	Stainless steel	304 (1.4301)	316 (1.4401)
39	Spring for valve cup	Stainless steel	301 (1.4310)	316 (1.4401)
70	Valve guide	Stainless steel	304 (1.4301)	316 (1.4401)
78	Nameplate	Stainless steel	304 (1.4301)	316 (1.4401)
79	Rivet	Stainless steel	304 (1.4301)	316 (1.4401)
63	Connecting piece	Stainless steel	304 (1.4301)	316 (1.4401)
<b>Chamber stack</b>				
4	Top chamber	Stainless steel	304 (1.4301)	316 (1.4401)
5	Upthrust disc	Carbon/ graphite HY22 in PTFE mass		
6	Top bearing	Stainless steel/ NBR	304 (1.4301)	316 (1.4401)
7	Neck ring	NBR/PPS		
8	Bearing	NBR		
9	Chamber	Stainless steel	304 (1.4301)	316 (1.4401)
11	Nut for split cone	Stainless steel	304 (1.4301)	316 (1.4401)
12	Split cone	Stainless steel	304 (1.4301)	316 (1.4401)
13	Impeller	Stainless steel	304 (1.4301)	316 (1.4401)
16	Shaft with coupling	Stainless steel	431 (1.4057)	329 (1.4460)
18	Cable guard	Stainless steel	304 (1.4301)	316 (1.4401)
18a, 18b	Screw for cable guard	Stainless steel	304 (1.4301)	316 (1.4401)
23	Rubber guard	NBR		
72	Wear ring	Stainless steel	304 (1.4301)	316 (1.4401)
<b>Suction interconnector</b>				
14	Suction interconnector	Stainless steel	304 (1.4301)	316 (1.4401)
15	Strainer	Stainless steel	304 (1.4301)	316 (1.4401)
17	Strap	Stainless steel	304 (1.4301)	316 (1.4401)
19	Nut for strap	Stainless steel	304 (1.4301)	316 (1.4401)
19a	Nut	Stainless steel	316 (1.4401)	316 (1.4401)
20	Motor cable			
22	Bolts	Stainless steel	316 (1.4401)	316 (1.4401)
28, 28a	Lock for strainer	Stainless steel	329 (1.4460)	329 (1.4460)

# 10" and larger wells - continued

## SP 800S (800 gpm) / 6, 8 inch motors

Pump model	Nom. head [ft]	Ph	Volts [V]	Motor [Hp]	Dimensions					Net weight (complete) [lb]	
					A [in. (mm)]	B [in. (mm)]	C [in. (mm)]	D [in. (mm)]	E [in. (mm)]		
<b>800S - Motor dia. 6 inch, 60 Hz, rated flow 800 gpm (6" NPT)</b>											
800S200-1A	64	3	230	20	▲	56.50 (1435)	30.83 (783)	25.67 (652)	5.63 (143)	8.31 (211)	180.0
		3	460	20	▲	56.50 (1435)	30.83 (783)	25.67 (652)	5.63 (143)	8.31 (211)	180.0
800S300-1	96	3	230	30	▲	61.23 (1555)	35.56 (903)	25.67 (652)	5.63 (143)	8.31 (211)	202.5
		3	460	30	▲	61.23 (1555)	35.56 (903)	25.67 (652)	5.63 (143)	8.31 (211)	202.5
800S400-2AA	131	3	460	40	▲	72.05 (1830)	40.28 (1023)	31.78 (807)	5.63 (143)	8.31 (211)	257.4
800S500-2A	162	3	460	50	☼	88.00 (2235)	56.11 (1425)	31.87 (810)	7.56 (192)	8.39 (213)	363.2
800S500-2	194	3	460	50	☼	88.00 (2235)	56.11 (1425)	31.87 (810)	7.56 (192)	8.39 (213)	363.2
800S600-3AA	197	3	460	60	*	87.92 (2233)	50.00 (1270)	37.92 (963)	7.56 (192)	8.39 (213)	490.8
<b>800S - Motor dia. 8 inch, 60 Hz, rated flow 800 gpm (6" NPT)</b>											
800S400-2AA	131	3	460	40	*	75.48 (1917)	43.71 (1110)	31.78 (807)	7.56 (192)	8.39 (213)	409.4
800S500-2A	162	3	460	50	*	77.45 (1967)	45.67 (1160)	31.78 (807)	7.56 (192)	8.39 (213)	431.4
800S500-2	187	3	460	50	*	77.45 (1967)	45.67 (1160)	31.78 (807)	7.56 (192)	8.39 (213)	438.0
800S600-3AA	229	3	460	60	*	87.92 (2233)	50.00 (1270)	37.92 (963)	7.56 (192)	8.39 (213)	490.8
800S750-3A	260	3	460	75	*	91.07 (2313)	53.15 (1350)	37.92 (963)	7.56 (192)	8.39 (213)	523.8
800S750-3	292	3	460	75	*	91.07 (2313)	53.15 (1350)	37.92 (963)	7.56 (192)	8.39 (213)	523.8
800S1000-4AA	327	3	460	100	*	106.62 (2708)	62.60 (1590)	44.02 (1118)	7.56 (192)	8.39 (213)	633.8
800S1000-4A	358	3	460	100	*	106.62 (2708)	62.60 (1590)	44.02 (1118)	7.56 (192)	8.39 (213)	633.8
800S1000-4	389	3	460	100	*	106.62 (2708)	62.60 (1590)	44.02 (1118)	7.56 (192)	8.39 (213)	633.8
800S1250-5AA	426	3	460	125	*	122.21 (3104)	72.05 (1830)	50.16 (1274)	7.56 (192)	8.39 (213)	748.3
800S1250-5A	456	3	460	125	*	122.21 (3104)	72.05 (1830)	50.16 (1274)	7.56 (192)	8.39 (213)	748.3
800S1250-5	487	3	460	125	*	122.21 (3104)	72.05 (1830)	50.16 (1274)	7.56 (192)	8.39 (213)	746.6

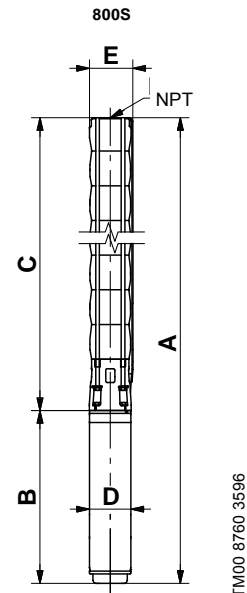

**E = Maximum diameter of pump including cable guard and motor.**

**Notes:**

Control box is required for 3-wire, single-phase applications. Data does not include control box. Performance conforms to ISO 9906, 1999 (E) Annex A. Minimum submergence is 2 feet.

- ▲ MS 6000C motor.
- ☼ Takes MMS 6 motor; not available as complete.
- \* Takes MMS 8000 motor; not available as complete.