

Sectional drawing, SP pump 4" smooth shaft (SP 35S - 77S)

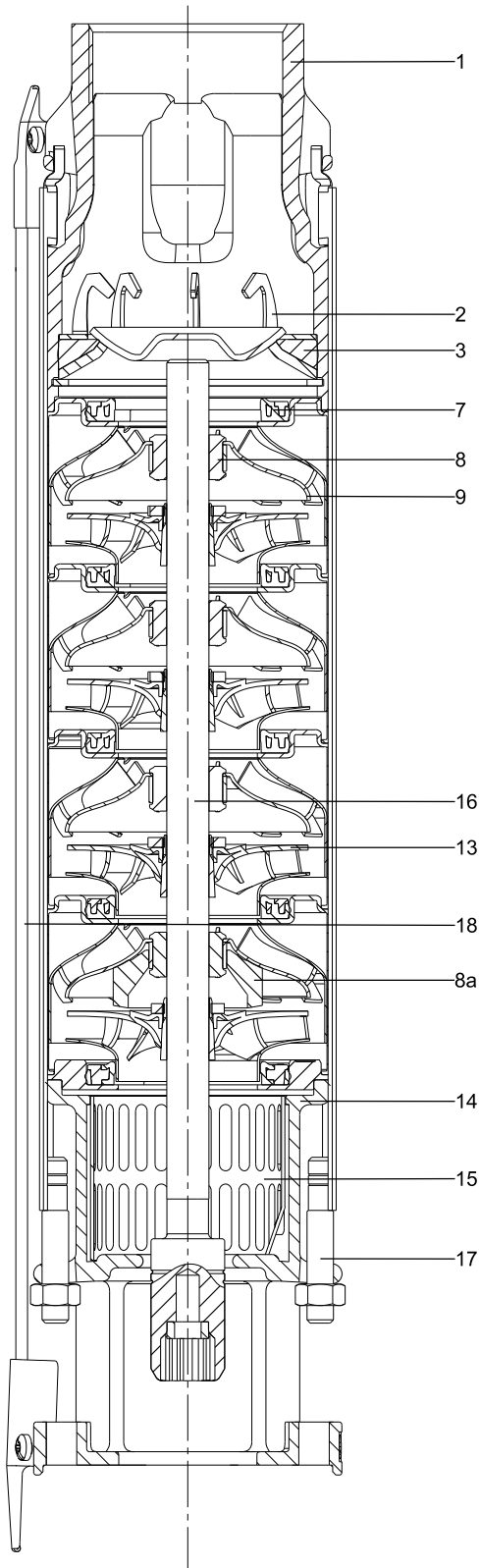

Material specification

Pos.	Component	Material	Standard N-version R-version		
			[AISI (EN)]		
1	Valve casing	Cast stainless steel	304 (1.4301)	316 (1.4401)	904L (1.4539)
2	Valve cup	Cast stainless steel	304 (1.4301)	316 (1.4401)	904L (1.4539)
3	Valve seat	NBR-FKM	NBR-FKM	NBR-FKM	NBR-FKM
7	Neck ring	TPU/PPS-FKM	TPU/ PPS-FKM	TPU/ PPS-FKM	TPU/ PPS-FKM
8	Bearing	LSR-FKM	LSR/FKM	LSR/FKM	LSR/FKM
8a	Washer for stop ring	Carbon/graphite HY22 in PTFE mass			
9	Chamber	Stainless steel	304 (1.4301)	316 (1.4401)	904L (1.4539)
13	Impeller	Stainless steel	304 (1.4301)	316 (1.4401)	904L (1.4539)
14	Suction interconnector	Cast stainless steel	304 (1.4308)	316 (1.4408)	904L (1.4517)
16	Shaft complete	Stainless steel	1.4057	1.4460	1.4462
17	Strap	Stainless steel	304 (1.4301)	316 (1.4401)	904L (1.4539)
18	Cable guard	Stainless steel	304 (1.4301)	316 (1.4401)	904L (1.4539)
	Strainer	Stainless steel	304 (1.4301)	316 (1.4401)	904L (1.4539)

Fig. 14 SP pump, 4" smooth shaft (SP 35S - 77S)

TM06 1110 1614

4" and larger wells - continued

SP 62S (62 gpm) / 4 inch motor

Pump model	Nom. head [ft]	Ph	Volts [V]	Motor [Hp]	Dimensions					Net weight (complete) [lb]	
					A [in. (mm)]	B [in. (mm)]	C [in. (mm)]	D [in. (mm)]	E [in. (mm)]		
62S - Motor dia. 4 inch, 3 wire motor, 60 Hz, rated 62 gpm (2" NPT)											
62S07-2	38	1	230	.75	■	28.35 (720)	13.08 (332)	15.28 (388)	3.75 (95)	3.98 (101)	29.7
		3	230	.75	■	26.97 (685)	11.70 (297)	15.28 (388)	3.75 (95)	3.98 (101)	26.7
		3	460	.75	■	26.97 (685)	11.70 (297)	15.28 (388)	3.75 (95)	3.98 (101)	26.7
		3	575	.75	■	26.97 (685)	11.70 (297)	15.28 (388)	3.75 (95)	3.98 (101)	26.7
62S10-3	58	1	230	1	■	31.89 (810)	13.67 (347)	18.23 (463)	3.75 (95)	3.98 (101)	33.0
		3	230	1	■	30.71 (780)	12.49 (317)	18.23 (463)	3.75 (95)	3.98 (101)	30.4
		3	460	1	■	30.71 (780)	12.49 (317)	18.23 (463)	3.75 (95)	3.98 (101)	30.2
		3	575	1	■	30.71 (780)	12.49 (317)	18.23 (463)	3.75 (95)	3.98 (101)	30.2
62S15-4	79	1	230	1.5	■	36.42 (925)	15.24 (387)	21.19 (538)	3.75 (95)	3.98 (101)	38.5
		3	230	1.5	■	34.85 (885)	13.67 (347)	21.19 (538)	3.75 (95)	3.98 (101)	35.0
		3	460	1.5	■	34.85 (885)	13.67 (347)	21.19 (538)	3.75 (95)	3.98 (101)	35.0
		3	575	1.5	■	34.85 (885)	13.67 (347)	21.19 (538)	3.75 (95)	3.98 (101)	34.8
62S20-5	100	1	230	2	●	43.71 (1110)	19.57 (497)	24.14 (613)	3.75 (95)	3.98 (101)	56.0
		3	230	2	■	39.38 (1000)	15.24 (387)	24.14 (613)	3.75 (95)	3.98 (101)	40.5
		3	460	2	■	39.38 (1000)	15.24 (387)	24.14 (613)	3.75 (95)	3.98 (101)	40.7
		3	575	2	■	39.38 (1000)	15.24 (387)	24.14 (613)	3.75 (95)	3.98 (101)	40.5
62S30-7	141	1	230	3	●	52.76 (1340)	22.72 (577)	30.04 (763)	3.75 (95)	3.98 (101)	68.3
		3	208-230	3	●	48.04 (1220)	18.00 (457)	30.04 (763)	3.75 (95)	3.98 (101)	55.1
		3	460	3	●	48.04 (1220)	18.00 (457)	30.04 (763)	3.75 (95)	3.98 (101)	55.1
62S50-9	182	1	230	5	●	62.60 (1590)	26.66 (677)	35.95 (913)	3.75 (95)	3.98 (101)	82.8
		3	208-230	5	●	58.67 (1490)	22.72 (577)	35.95 (913)	3.75 (95)	3.98 (101)	71.8
		3	460	5	●	58.67 (1490)	22.72 (577)	35.95 (913)	3.75 (95)	3.98 (101)	71.8
62S50-12	244	1	230	5	●	71.46 (1815)	26.66 (677)	44.81 (1138)	3.75 (95)	3.98 (101)	88.1
		3	208-230	5	●	67.52 (1715)	22.72 (577)	44.81 (1138)	3.75 (95)	3.98 (101)	77.1
		3	460	5	●	67.52 (1715)	22.72 (577)	44.81 (1138)	3.75 (95)	3.98 (101)	77.1
62S75-14	285	3	208-230	7.5	●	77.37 (1965)	26.66 (677)	50.71 (1288)	3.75 (95)	3.98 (101)	91.6
		3	460	7.5	●	77.37 (1965)	26.66 (677)	50.71 (1288)	3.75 (95)	3.98 (101)	91.6
		3	575	7.5	●	77.37 (1965)	26.66 (677)	50.71 (1288)	3.75 (95)	3.98 (101)	91.6
62S75-17	347	3	208-230	7.5	●	86.23 (2190)	26.66 (677)	59.57 (1513)	3.75 (95)	3.98 (101)	96.9
		3	460	7.5	●	86.23 (2190)	26.66 (677)	59.57 (1513)	3.75 (95)	3.98 (101)	96.9
		3	575	7.5	●	86.23 (2190)	26.66 (677)	59.57 (1513)	3.75 (95)	3.98 (101)	96.9
62S100-20	409	3	460	10	●	99.02 (2515)	30.60 (777)	68.43 (1738)	3.75 (95)	3.98 (101)	111.0
		3	575	10	●	99.02 (2515)	30.60 (777)	68.43 (1738)	3.75 (95)	3.98 (101)	111.0
62S100-22	450	3	460	10	●	104.93 (2665)	30.60 (777)	74.34 (1888)	3.75 (95)	3.98 (101)	114.5
		3	575	10	●	104.93 (2665)	30.60 (777)	74.34 (1888)	3.75 (95)	3.98 (101)	114.5
62S100-24	491	3	460	10	●	110.83 (2815)	30.60 (777)	80.24 (2038)	3.75 (95)	3.98 (101)	118.0
		3	575	10	●	110.83 (2815)	30.60 (777)	80.24 (2038)	3.75 (95)	3.98 (101)	118.0

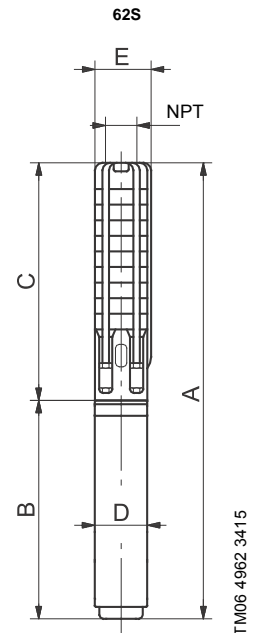

E = Maximum diameter of pump including cable guard and motor.

Notes:

Control box is required for 3-wire, single-phase applications. Data does not include control box. Performance conforms to ISO 9906: 1999 (E) Annex A. Minimum submergence is 2 feet.

- MS 402 motor.
- MS 4000 motor.

4" and larger wells - continued

SP 62S (62 gpm) / 6 inch motor

Pump model	Nom. head [ft]	Ph	Volts [V]	Motor [Hp]	Dimensions					Net weight (complete) [lb]
					A [in. (mm)]	B [in. (mm)]	C [in. (mm)]	D [in. (mm)]	E [in. (mm)]	
62S - Motor dia. 6 inch, 60 Hz, rated 62 gpm (2" NPT)										
62S75-14	285	3	208-230	7.5 ▲	76.70 (1948)	23.51 (597)	53.19 (1351)	5.50 (140)	5.50 (140)	119.3
		3	460	7.5 ▲	76.70 (1948)	23.51 (597)	53.19 (1351)	5.50 (140)	5.50 (140)	119.3
		3	575	7.5 ▲	76.70 (1948)	23.51 (597)	53.19 (1351)	5.50 (140)	5.50 (140)	119.3
62S75-17	347	3	208-230	7.5 ▲	85.56 (2173)	23.51 (597)	62.05 (1576)	5.50 (140)	5.50 (140)	124.6
		3	460	7.5 ▲	85.56 (2173)	23.51 (597)	62.05 (1576)	5.50 (140)	5.50 (140)	124.6
		3	575	7.5 ▲	85.56 (2173)	23.51 (597)	62.05 (1576)	5.50 (140)	5.50 (140)	124.6
62S100-20	409	3	208-230	10 ▲	95.60 (2428)	24.69 (627)	70.91 (1801)	5.50 (140)	5.50 (140)	136.4
		3	460	10 ▲	95.60 (2428)	24.69 (627)	70.91 (1801)	5.50 (140)	5.50 (140)	136.4
		3	575	10 ▲	95.60 (2428)	24.69 (627)	70.91 (1801)	5.50 (140)	5.50 (140)	136.4
62S100-22	450	3	208-230	10 ▲	101.50 (2578)	24.69 (627)	76.82 (1951)	5.50 (140)	5.50 (140)	139.9
		3	460	10 ▲	101.50 (2578)	24.69 (627)	76.82 (1951)	5.50 (140)	5.50 (140)	139.9
		3	575	10 ▲	101.50 (2578)	24.69 (627)	76.82 (1951)	5.50 (140)	5.50 (140)	139.9
62S100-24	491	3	208-230	10 ▲	107.41 (2728)	24.69 (627)	82.72 (2101)	5.50 (140)	5.50 (140)	143.4
		3	460	10 ▲	107.41 (2728)	24.69 (627)	82.72 (2101)	5.50 (140)	5.50 (140)	143.4
		3	575	10 ▲	107.41 (2728)	24.69 (627)	82.72 (2101)	5.50 (140)	5.50 (140)	143.4

Notes:
Control box is required for 3-wire, single-phase applications. Data does not include control box.
Performance conforms to ISO 9906. 1999 (E) Annex A. Minimum submergence is 2 feet.

▲ MS 6000C motor.

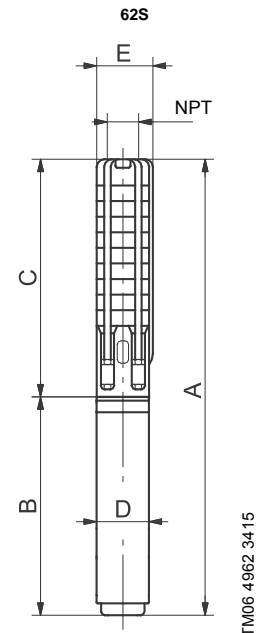

E = Maximum diameter of pump including cable guard and motor.