

## Sectional drawing, SP pump 4" spline shaft (SP 5S - 25S)

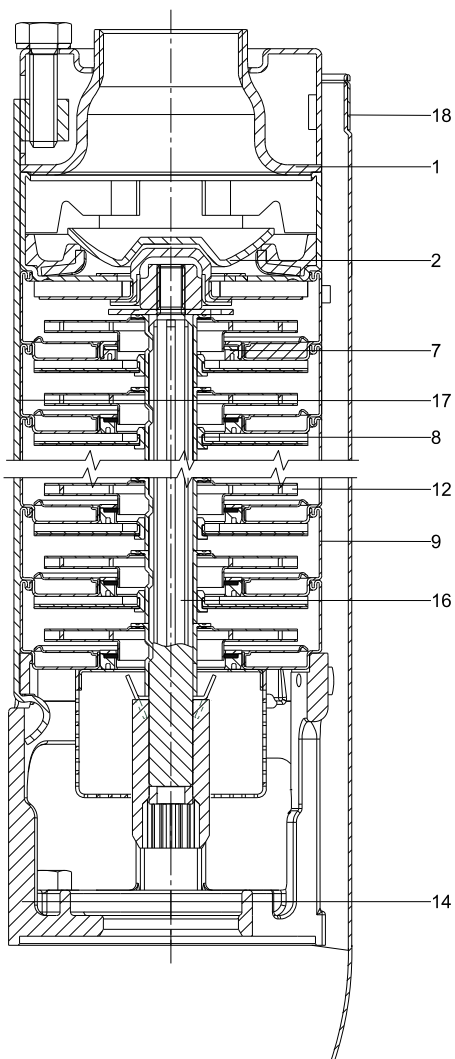

### Material specification

Pos.	Component	Material	Standard N-version R-version		
			[AISI (EN)]		
1	Valve casing	Stainless steel	304 (1.4301)	316 (1.4401)	904L (1.4539)
2	Valve cup	Stainless steel	304 (1.4301)	316 (1.4401)	904L (1.4539)
7	Neck ring	NBR/TPU			
8	Bearing	NBR			
9	Chamber	Stainless steel	304 (1.4301)	316 (1.4401)	904L (1.4539)
12	Impeller	Stainless steel	304 (1.4301)	316 (1.4401)	904L (1.4539)
14	Suction interconnector	Cast stainless steel	304 (1.4308)	316 (1.4408)	904L (1.4517)
16	Shaft complete	Stainless steel	431 (1.4057)	329 (1.4460)	904L (1.4462)
17	Strap	Stainless steel	304 (1.4301)	316 (1.4401)	904L (1.4539)
18	Cable guard	Stainless steel	304 (1.4301)	316 (1.4401)	904L (1.4539)
	Washer for stop ring	Carbon/graphite HY22 in PTFE mass			
	Strainer	Stainless steel	304 (1.4301)	316 (1.4401)	904L (1.4539)
	Valve seat	Rubber type	NBR	NBR-FKM	NBR-FKM

Fig. 13 SP pump, 4" spline shaft (SP 5S - 25S)

TM06 93 1614

## 4" and larger wells - continued

### SP 25S (25 gpm) / 4, 6 inch motors

Pump model	Nom. head [ft]	Ph	Volts [V]	Motor [Hp]	Dimensions					Net weight (complete) [lb]		
					A [in. (mm)]	B [in. (mm)]	C [in. (mm)]	D [in. (mm)]	E [in. (mm)]			
<b>25S, motor dia. 4 inch, 2 wire motor, 60 Hz - rated flow 25 gpm (1.5" NPT)</b>												
25S05-3	60	1	115	.5	■	19.61 (498)	11.03 (280)	8.59 (218)	3.74 (95)	3.98 (101)	21.6	
			230	.5	■	19.61 (498)	11.03 (280)	8.59 (218)	3.74 (95)	3.98 (101)	21.6	
25S07-5	99	1	230	.75	■	21.86 (555)	11.62 (295)	10.24 (260)	3.74 (95)	3.98 (101)	23.4	
25S10-7	139	1	230	1	■	24.10 (612)	12.21 (310)	11.89 (302)	3.74 (95)	3.98 (101)	25.2	
25S15-9	179	1	230	1.5	■	27.25 (692)	13.71 (348)	13.55 (344)	3.74 (95)	3.98 (101)	28.8	
<b>25S, motor dia. 4 inch, 3 wire motor, 60 Hz - rated flow 25 gpm (1.5" NPT)</b>												
25S05-3	60	1	115	.5	■	19.61 (498)	11.03 (280)	8.59 (218)	3.74 (95)	3.98 (101)	21.6	
			230	.5	■	19.61 (498)	11.03 (280)	8.59 (218)	3.74 (95)	3.98 (101)	21.6	
25S07-5	99	1	230	.75	■	21.86 (555)	11.62 (295)	10.24 (260)	3.74 (95)	3.98 (101)	23.4	
25S10-7	139	1	230	1	■	24.10 (612)	12.21 (310)	11.89 (302)	3.74 (95)	3.98 (101)	25.2	
25S15-9	179	3	1	230	1.5	■	27.25 (692)	13.71 (348)	13.55 (344)	3.74 (95)	3.98 (101)	29.7
			230	1.5	■	25.75 (654)	12.21 (310)	13.55 (344)	3.74 (95)	3.98 (101)	27.0	
			460	1.5	■	25.75 (654)	12.21 (310)	13.55 (344)	3.74 (95)	3.98 (101)	28.8	
25S20-11	219	3	1	230	2	●	34.69 (881)	19.49 (495)	15.20 (386)	3.74 (95)	3.98 (101)	33.1
			230	2	■	28.90 (734)	13.71 (348)	15.20 (386)	3.74 (95)	3.98 (101)	37.0	
			460	2	■	28.90 (734)	13.71 (348)	15.20 (386)	3.74 (95)	3.98 (101)	33.3	
25S30-15	298	3	1	230	3	●	41.11 (1044)	22.60 (574)	18.51 (470)	3.74 (95)	3.98 (101)	61.2
			230	3	●	36.50 (927)	18.00 (457)	18.51 (470)	3.74 (95)	3.98 (101)	53.1	
			460	3	●	36.50 (927)	18.00 (457)	18.51 (470)	3.74 (95)	3.98 (101)	53.1	
25S50-26	517	3	1	230	5	●	54.22 (1377)	26.62 (676)	27.60 (701)	3.74 (95)	3.98 (101)	72.9
			230	5	●	50.32 (1278)	22.72 (577)	27.60 (701)	3.74 (95)	3.98 (101)	72.9	
			460	5	●	50.32 (1278)	22.72 (577)	27.60 (701)	3.74 (95)	3.98 (101)	72.9	
<b>SP 25S, motor dia. 6 inch, 60 Hz - rated flow 25 gpm (1.5" NPT)</b>												
25S75-39DS	775	3	230	7.5	▲	66.06 (1678)	23.50 (597)	42.56 (1081)	5.63 (143)	5.43 (138)	122.1	
			460	7.5	▲	66.06 (1678)	23.50 (597)	42.56 (1081)	5.63 (143)	5.43 (138)	122.1	
25S100-52DS	1034	3	460	10	▲	90.17 (2290)	24.69 (627)	65.48 (1663)	5.63 (143)	5.51 (140)	163.1	

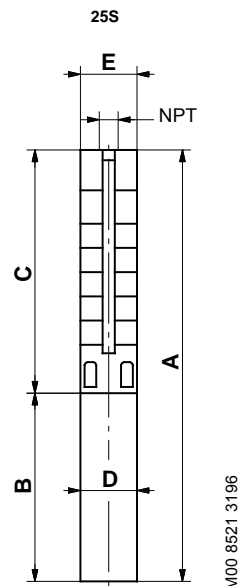

E = Maximum diameter of pump including cable guard and motor.

TM00 8521 3196

#### Notes:

Control box is required for 3-wire, single-phase applications. Data does not include control box.

DS designation = Built into sleeve, 1 - 1/2" NPT, 6" minimum well diameter.

Performance conforms to ISO 9906. 1999 (E) Annex A. Minimum submergence is 2 feet.

- MS 402 motor.
- MS 4000 motor.
- ▲ MS 6000C motor.