

Performance curves

UPS 50-80/4
1 phase 115 V, 230 V, 60 Hz

Performance curves

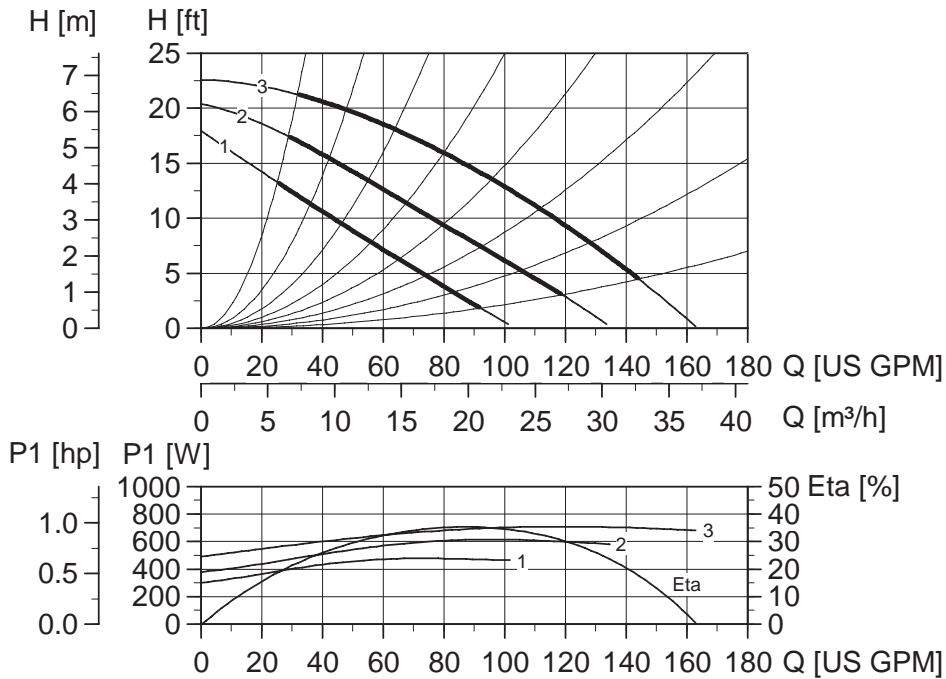

Note: ETA is calculated as wire-to-water efficiency.

Weights and volume

	Cast Iron				Bronze			
	lbs.	ft ³	Kg	m ³	lbs.	ft ³	Kg	m ³
Net weight	60.2		27.3		66.8		30.3	
Gross weight	72.5		32.9		79.1		35.9	
Shipping volume		2.90		0.082		2.90		0.082

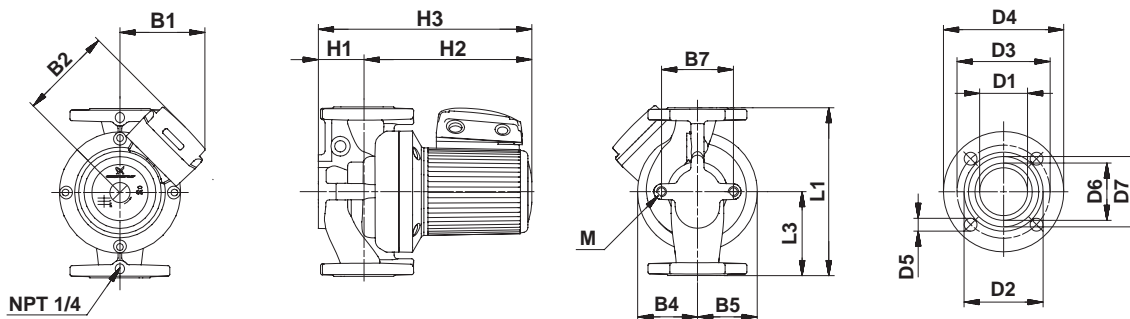

Dimensions

	L1	L3	B1	B2	B4	B5	B7	H1	H2	H3	D1	D2	D3	D4	D5	D6	D7	M
[Inches]	11 1/2	7	5 3/4	6 11/16	4 3/8	3 15/16	4 3/4	3 1/4	10 7/8	14 1/8	2 1/8	3 7/16	4 1/16	5 1/4	9/16	2 1/2	3 1/16	
[mm]	292	177.8	145	169	110	100	120	82	277	359	53	87.5	103	133	14	63	77.8	M12

Performance curves

UPS 50-80/4
3 phase 208-230 V, 460 V, 575 V★, 60 Hz

Performance curves

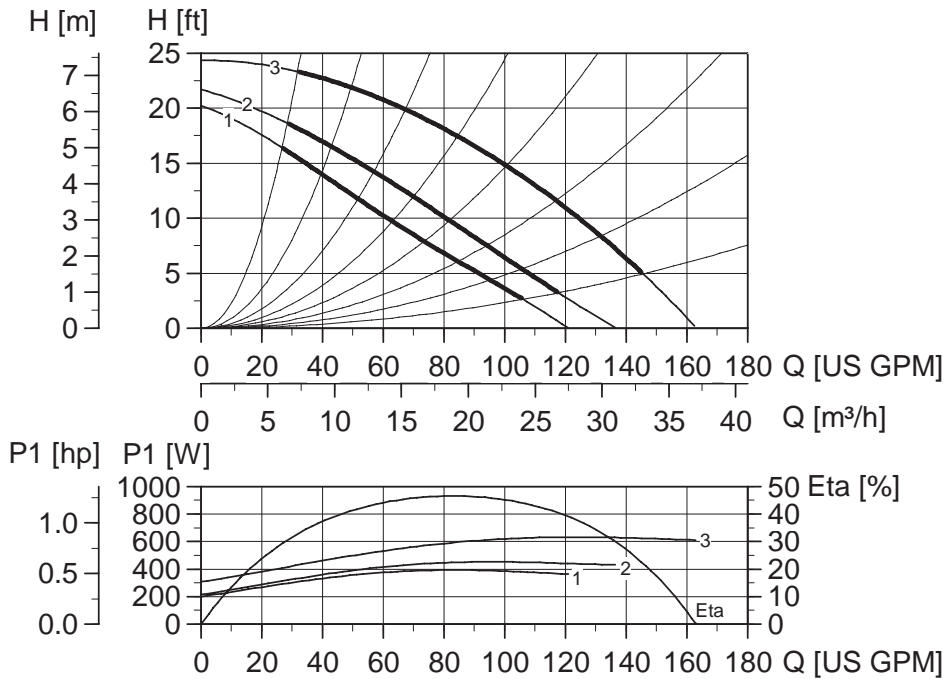

Note: ETA is calculated as wire-to-water efficiency.

Weights and volume

	Cast Iron				Bronze			
	lbs.	ft ³	Kg	m ³	lbs.	ft ³	Kg	m ³
Net weight	59.5		27		66.8		30.3	
Gross weight	71.9		32.6		79.1		35.9	
Shipping volume		2.90		0.082		2.90		0.082

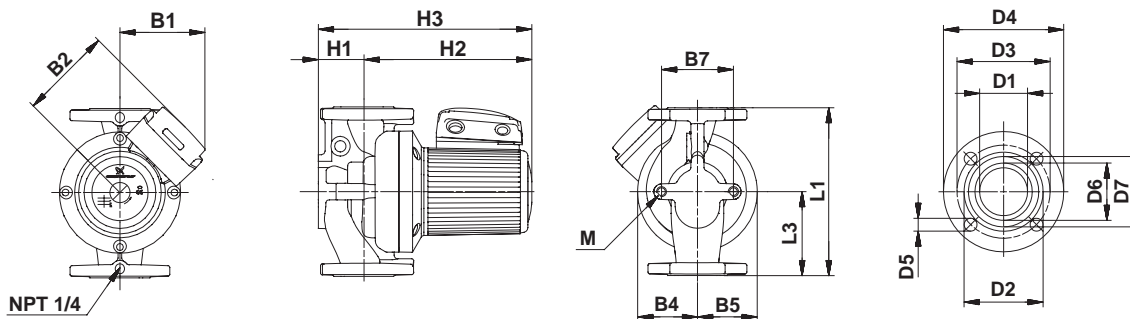

Dimensions

	L1	L3	B1	B2	B4	B5	B7	H1	H2	H3	D1	D2	D3	D4	D5	D6	D7	M
[Inches]	11 1/2	7	5 3/4	6 11/16	4 3/8	3 15/16	4 3/4	3 1/4	10 7/8	14 1/8	2 1/8	3 7/16	4 1/16	5 1/4	9/16	2 1/2	3 1/16	
[mm]	292	177.8	145	169	110	100	120	82	277	359	53	87.5	103	133	14	63	77.8	M12

★Canada only

TM00 9502 0697

TM02 0730 5100