

# Performance curves

UPS 32-80/2  
1 phase 115 V, 230 V, 60 Hz

## Performance curves

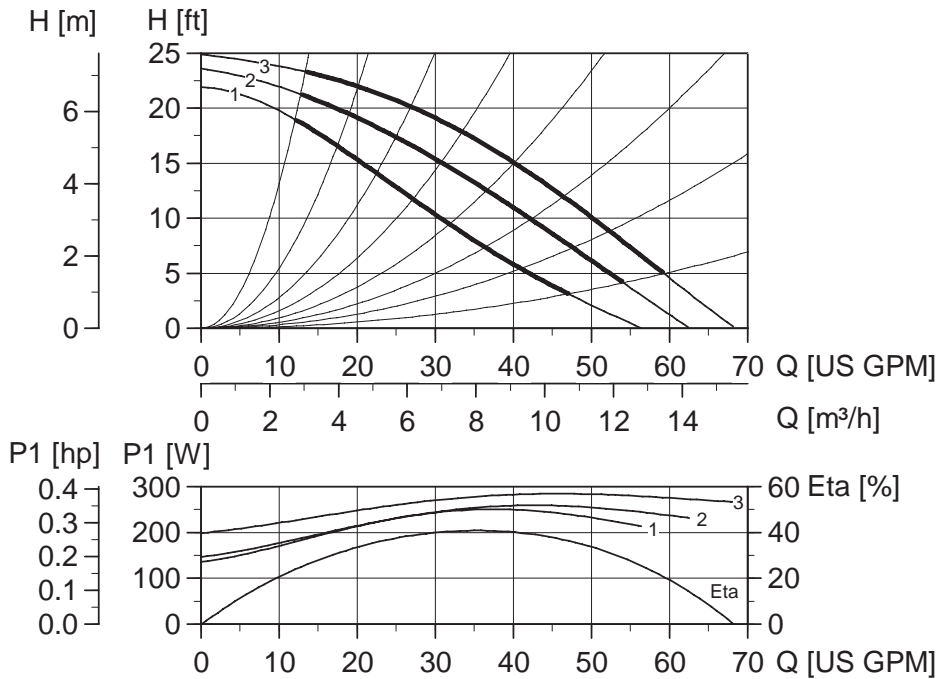

Note: ETA is calculated as wire-to-water efficiency.

## Weights and volume

|                 | Cast Iron |                 |      |                | Bronze |                 |      |                |
|-----------------|-----------|-----------------|------|----------------|--------|-----------------|------|----------------|
|                 | lbs.      | ft <sup>3</sup> | Kg   | m <sup>3</sup> | lbs.   | ft <sup>3</sup> | Kg   | m <sup>3</sup> |
| Net weight      | 35.9      |                 | 16.3 |                | 39.2   |                 | 17.8 |                |
| Gross weight    | 44.1      |                 | 20   |                | 47.4   |                 | 21.5 |                |
| Shipping volume |           | 1.70            |      | 0.048          |        | 1.70            |      | 0.048          |

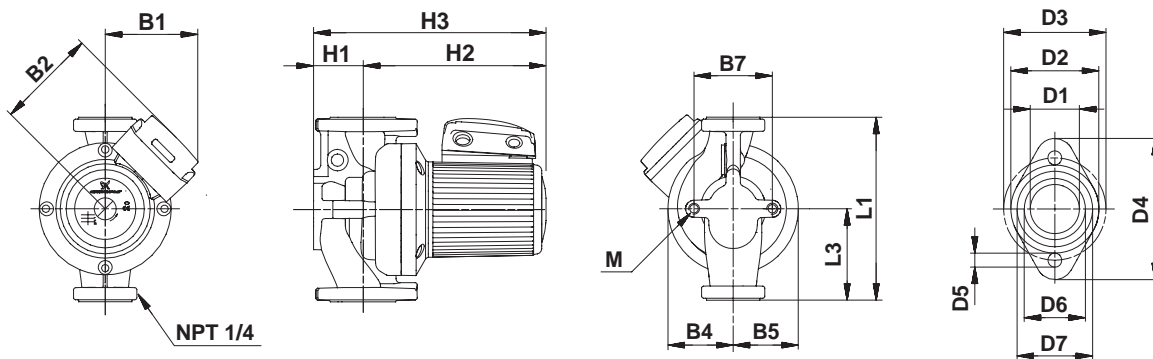

## Dimensions

|          | L1    | L3    | B1     | B2     | B4 | B5 | B7     | H1      | H2     | H3      | D1     | D2     | D3     | D4    | D5  | D6      | D7    | M   |
|----------|-------|-------|--------|--------|----|----|--------|---------|--------|---------|--------|--------|--------|-------|-----|---------|-------|-----|
| [Inches] | 11    | 5 1/2 | 5 5/16 | 5 9/16 | 3  | 3  | 3 3/16 | 2 11/16 | 9 7/16 | 12 1/16 | 1 7/16 | 2 9/16 | 3 7/16 | 4 5/8 | 1/2 | 1 13/16 | 2 1/4 |     |
| [mm]     | 279.4 | 139.7 | 135    | 141    | 75 | 75 | 80     | 68      | 239    | 307     | 35.9   | 64     | 80     | 117   | 12  | 46      | 57    | M12 |

# Performance curves

UPS 32-80/2  
3 phase 208-230 V, 460 V, 575 V★, 60 Hz

## Performance curves

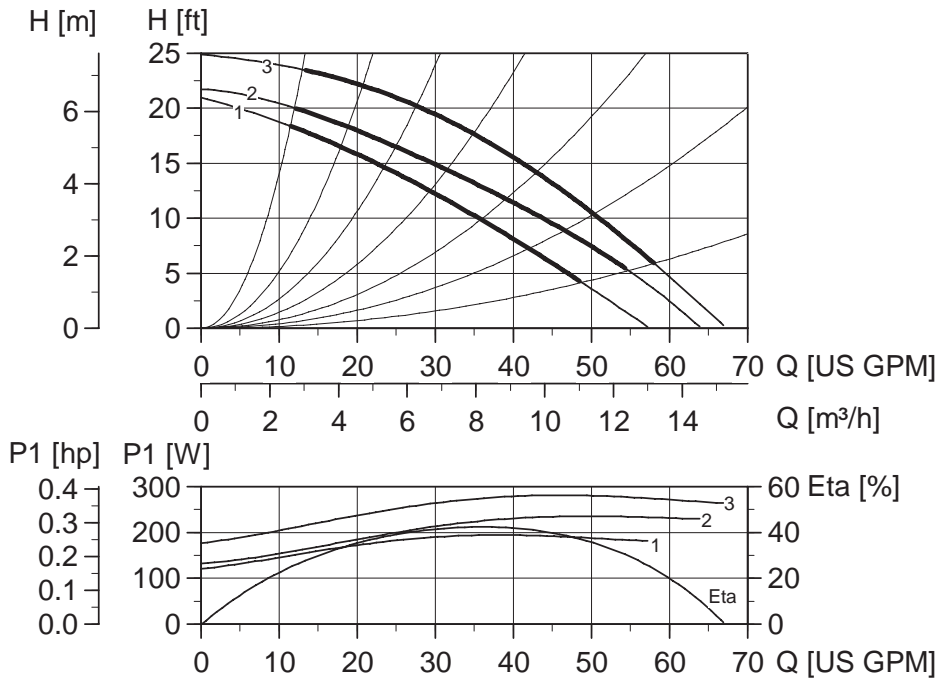

Note: ETA is calculated as wire-to-water efficiency.

## Weights and volume

|                 | Cast Iron |                 |      |                | Bronze |                 |      |                |
|-----------------|-----------|-----------------|------|----------------|--------|-----------------|------|----------------|
|                 | lbs.      | ft <sup>3</sup> | Kg   | m <sup>3</sup> | lbs.   | ft <sup>3</sup> | Kg   | m <sup>3</sup> |
| Net weight      | 35.9      |                 | 16.3 |                | 39.2   |                 | 17.8 |                |
| Gross weight    | 44.1      |                 | 20   |                | 47.4   |                 | 21.5 |                |
| Shipping volume |           | 1.70            |      | 0.048          |        | 1.70            |      | 0.048          |

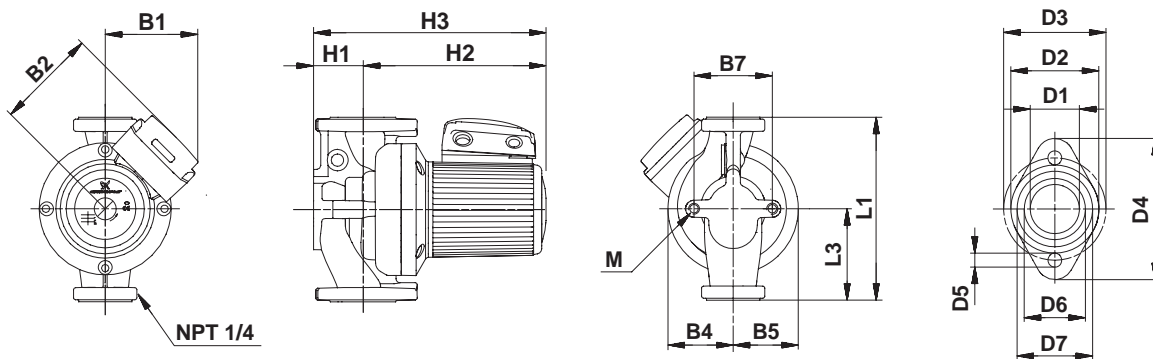

## Dimensions

|          | L1    | L3    | B1     | B2     | B4 | B5 | B7     | H1      | H2     | H3      | D1     | D2     | D3     | D4    | D5  | D6      | D7    | M   |
|----------|-------|-------|--------|--------|----|----|--------|---------|--------|---------|--------|--------|--------|-------|-----|---------|-------|-----|
| [Inches] | 11    | 5 1/2 | 5 5/16 | 5 9/16 | 3  | 3  | 3 3/16 | 2 11/16 | 9 7/16 | 12 1/16 | 1 7/16 | 2 9/16 | 3 7/16 | 4 5/8 | 1/2 | 1 13/16 | 2 1/4 |     |
| [mm]     | 279.4 | 139.7 | 135    | 141    | 75 | 75 | 80     | 68      | 239    | 307     | 35.9   | 64     | 80     | 117   | 12  | 46      | 57    | M12 |

★Canada only

TM00 9494 0697

TM02 0729 5100