



Submittal Data Information

KV Series Vertical Close Coupled Pumps

301-1104

EFFECTIVE: MAY 1, 2010

SUPERSEDES: JANUARY 8, 2010

1760 RPM MODEL 4009

JOB _____ ENGINEER _____

CONTRACTOR _____ REP. _____

ITEM NO.	MODEL NO.	IMPELLER DIA.	G.P.M.	HEAD/FT.	H.P.	ELEC. CHAR.

WEIGHT _____ PUMP/MOTOR _____

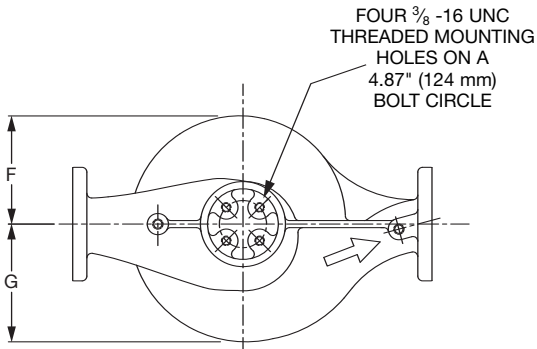
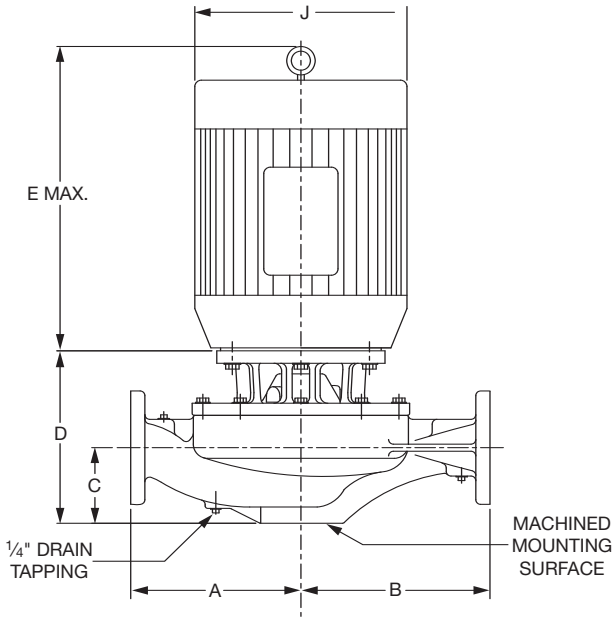

PUMP WITH OPTIONAL SUPPORT STAND

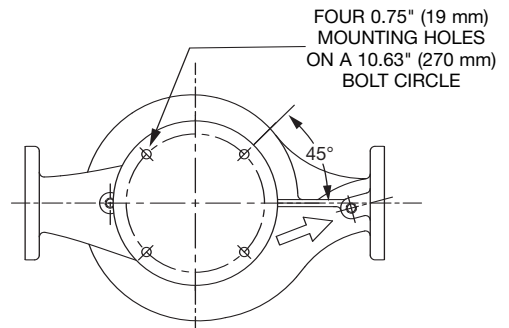
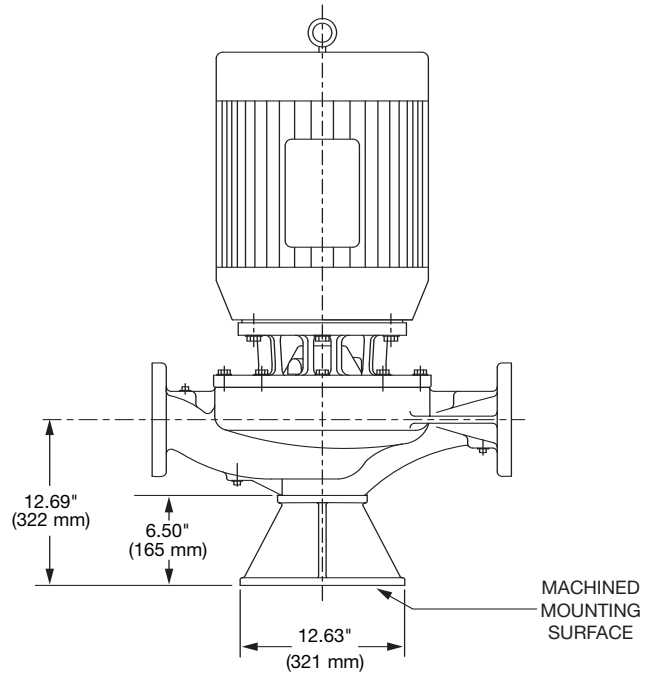

DIMENSIONS

*A & B Dimensions apply for all pump sizes.

Model No.	Conn.	Motor Frame	HP 1760 RPM	Flange Size ASA	A*	B*	C	D	E MAX	F	G	H	J DIA
4009	4 x 4 (102 x 102)	182JM	3	4 (102)	11.00 (279) if ANSI Class 125	13.00 (330) if ANSI Class 125	6.19 (157)	10.58 (269)	13.94 (354)	6.28 (160)	7.25 (184)	0.25 (6)	7.88 (200)
		184JM	5					10.58 (269)	15.58 (396)				7.88 (200)
		213JM	7.5					10.76 (273)	16.68 (424)				9.56 (243)
		215JM	10					10.76 (273)	18.18 (462)				9.56 (243)
		254JM	15					11.39 (289)	17.83 (453)				12.94 (329)

English dimensions are in inches. Metric dimensions are in millimeters. Metric data is presented in ().
Do not use for construction purposes unless certified.

MATERIALS OF CONSTRUCTION

Item	BRONZE FITTED		ALL IRON	
	Standard Pump Construction	Optional	Standard	Optional
Casing	Cast Iron ASTM A48 Class 30A	N/A	Cast Iron ASTM A48 Class 30A	N/A
Impeller	Bronze ASTM B584-836	CF	Cast Iron ASTM A48 Class 30A	CF
Wear Ring	None	Bronze ASTM B584-932 SAE660	None	N/A
Shaft	Carbon Steel	St. Steel AISI 416 ASTM A582	Carbon Steel	St. Steel AISI 416 ASTM A582
Shaft Sleeve	Bronze ASTM B584-932 SAE660	St. Steel AISI 303 ASTM A276	St. Steel AISI 303 ASTM A276	CF
Mechanical Seal	Ceramic / EPT	Tungsten Carbide / EPT	Ceramic / EPT	Tungsten Carbide / EPT
Seal Flush Line	Copper	CF	Stainless Steel	CF
Support Stand	N/A	Ductile Iron ASTM A536-84 Grade: 65-45-12	N/A	Ductile Iron ASTM A536-84 Grade: 65-45-12

CF - Consult Factory

N/A - Not Available

OPERATING SPECIFICATIONS

	Standard		Optional
	ANSI Class 125	ANSI Class 250	
Flange			
Pressure	175 PSIG* (1210 KPA)	300 PSIG** (2070 KPA)	CF
Temperature	250°F (120°C)	250°F (120°C)	CF

Motors: All NEMA Standard (T Frame)
 * In accordance with ANSI Standard B16.1 Class 125
 ** In accordance with ANSI Standard B16.1 Class 250 Dim.

MAXIMUM ASSEMBLY WEIGHT

Motor Frame	Weight without Optional Stand Lbs (Kg)	Weight with Optional Stand Lbs (Kg)
182JM - 184JM	239 (108)	286 (130)
213JM - 215JM	308 (140)	355 (161)
254JM - 256JM	414 (188)	461 (209)

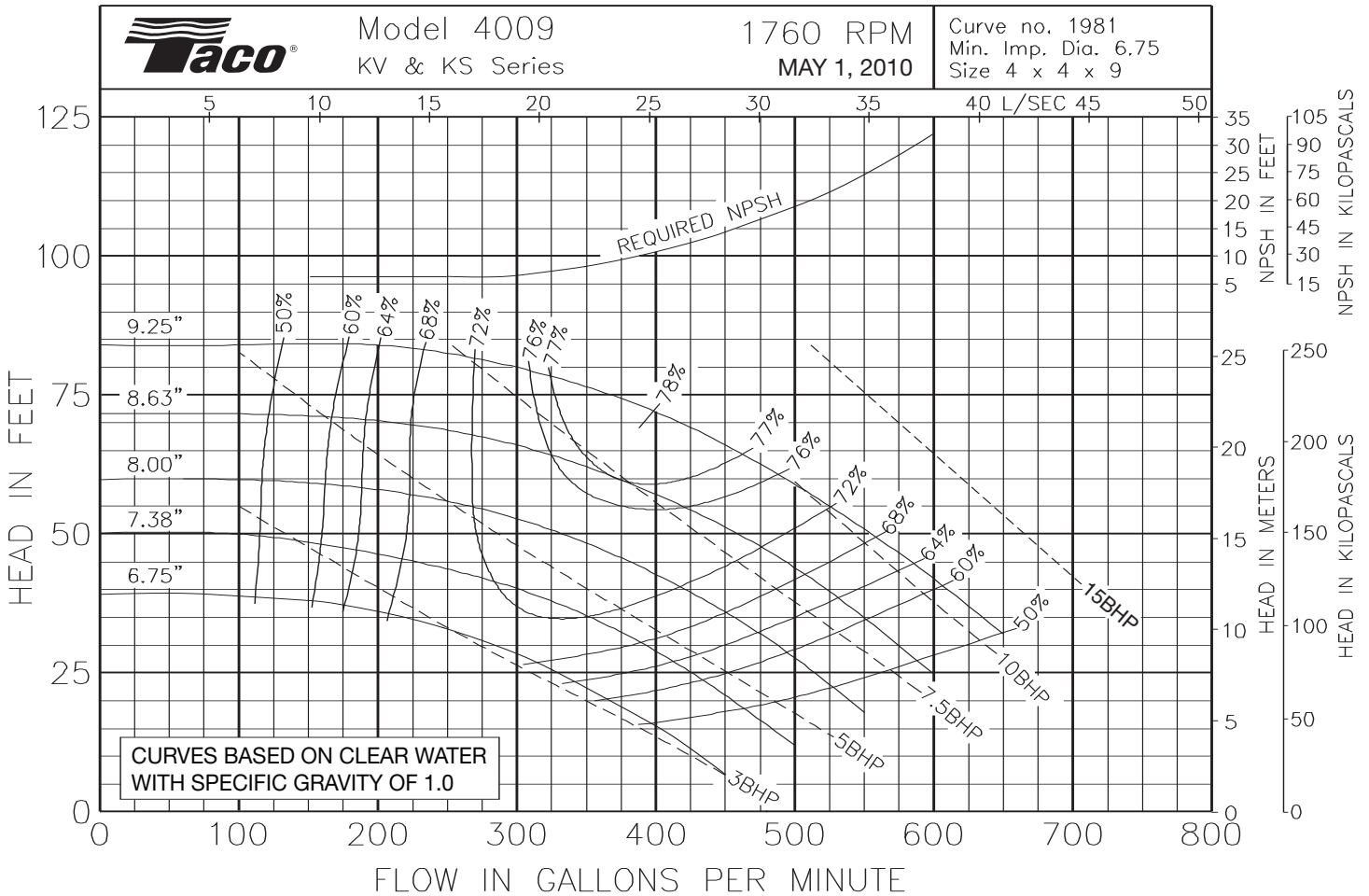

Comments:

Do it Once. Do it Right.®

TACO, INC., 1160 Cranston Street, Cranston, RI 02920 Telephone: (401) 942-8000 FAX: (401) 942-2360.
TACO (Canada), Ltd., 8450 Lawson Road, Unit #3, Milton, Ontario L9T 0J8. Telephone: 905/564-9422. FAX: 905/564-9436.
 Visit our web site at: <http://www.taco-hvac.com>

Printed in USA
 Copyright 2010
 TACO, Inc.



Submittal Data Information

KV Series Vertical Close Coupled Pumps

301-1118

EFFECTIVE: MAY 1, 2010

SUPERSEDES: JANUARY 8, 2010

3500 RPM MODEL 4009

JOB _____ ENGINEER _____

CONTRACTOR _____ REP. _____

ITEM NO.	MODEL NO.	IMPELLER DIA.	G.P.M.	HEAD/FT.	H.P.	ELEC. CHAR.
----------	-----------	---------------	--------	----------	------	-------------

WEIGHT _____ PUMP/MOTOR _____

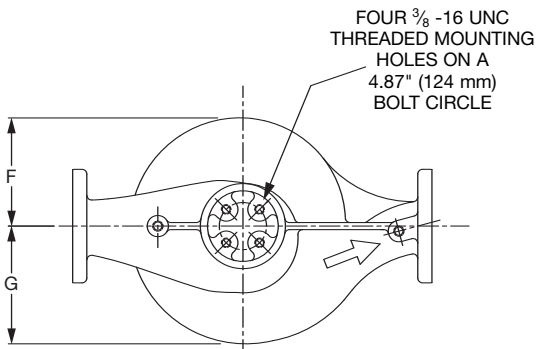
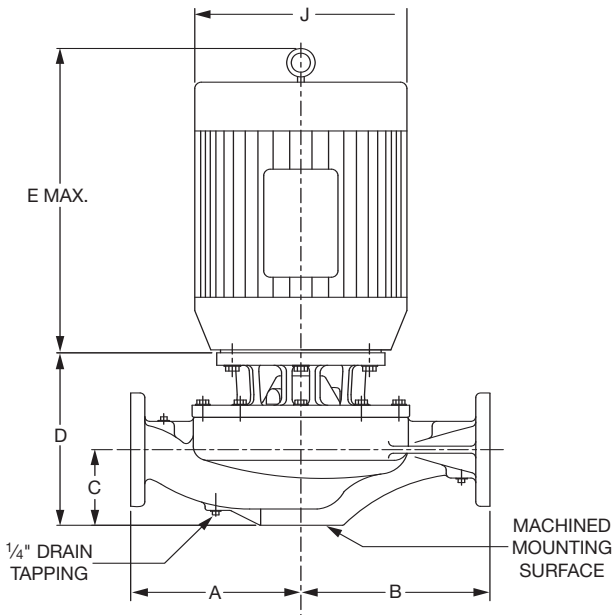

PUMP WITH OPTIONAL SUPPORT STAND

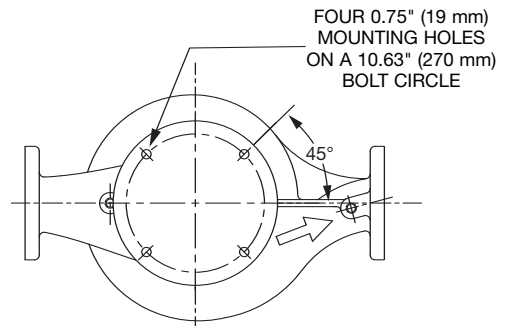
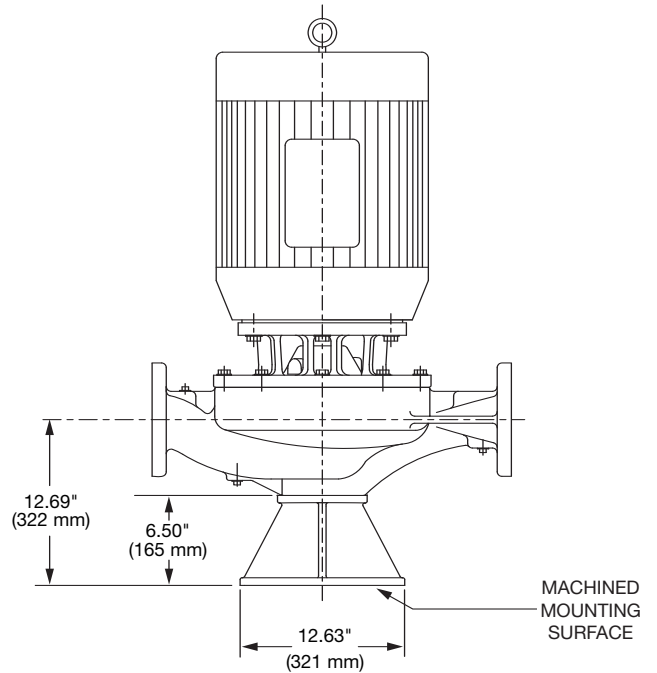

DIMENSIONS

*A & B Dimensions apply for all pump sizes.

Model No.	Conn.	Motor Frame	HP 3500 RPM	Flange Size ASA	A*	B*	C	D	E MAX	F	G	H	J DIA
4009	4 x 4 (102 x 102)	256JM	25	4 (102)	11.00 (279) if ANSI Class 125	13.00 (330) if ANSI Class 125	6.19 (157)	11.39 (289)	19.91 (506)	6.28 (160)	7.25 (184)	0.25 (6)	12.94 (329)
		284JM	30					11.39 (289)	23.39 (594)				15.29 (388)
		286JM	40					11.39 (289)	23.39 (594)				15.29 (388)
		324JM	50					11.39 (289)	25.28 (642)				17.85 (453)
		326JM	60**					11.39 (289)	25.28 (642)				17.85 (453)

English dimensions are in inches. Metric dimensions are in millimeters. Metric data is presented in ().
Do not use for construction purposes unless certified.

** Not available in TEFC.

MATERIALS OF CONSTRUCTION

Item	BRONZE FITTED		ALL IRON	
	Standard Pump Construction	Optional	Standard	Optional
Casing	Cast Iron ASTM A48 Class 30A	N/A	Cast Iron ASTM A48 Class 30A	N/A
Impeller	Bronze ASTM B584-836	CF	Cast Iron ASTM A48 Class 30A	CF
Wear Ring	None	Bronze ASTM B584-932 SAE660	None	N/A
Shaft	Carbon Steel	St. Steel AISI 416 ASTM A582	Carbon Steel	St. Steel AISI 416 ASTM A582
Shaft Sleeve	Bronze ASTM B584-932 SAE660	St. Steel AISI 303 ASTM A276	St. Steel AISI 303 ASTM A276	CF
Mechanical Seal	Ceramic / EPT	Tungsten Carbide / EPT	Ceramic / EPT	Tungsten Carbide / EPT
Seal Flush Line	Copper	CF	Stainless Steel	CF
Support Stand	N/A	Ductile Iron ASTM A536-84 Grade: 65-45-12	N/A	Ductile Iron ASTM A536-84 Grade: 65-45-12

CF - Consult Factory

N/A - Not Available

OPERATING SPECIFICATIONS

	Standard		Optional
	ANSI Class 125	ANSI Class 250	
Flange			
Pressure	175 PSIG* (1210 KPA)	300 PSIG** (2070 KPA)	CF
Temperature	250°F (120°C)	250°F (120°C)	CF

Motors: All NEMA Standard (T Frame)
 * In accordance with ANSI Standard B16.1 Class 125
 ** In accordance with ANSI Standard B16.1 Class 250 Dim.

MAXIMUM ASSEMBLY WEIGHT

Motor Frame	Weight without Optional Stand Lbs (Kg)	Weight with Optional Stand Lbs (Kg)
254JM - 256JM	445 (202)	492 (223)
284JM - 286JM	555 (252)	602 (273)
324JM - 326JM	766 (347)	813 (369)

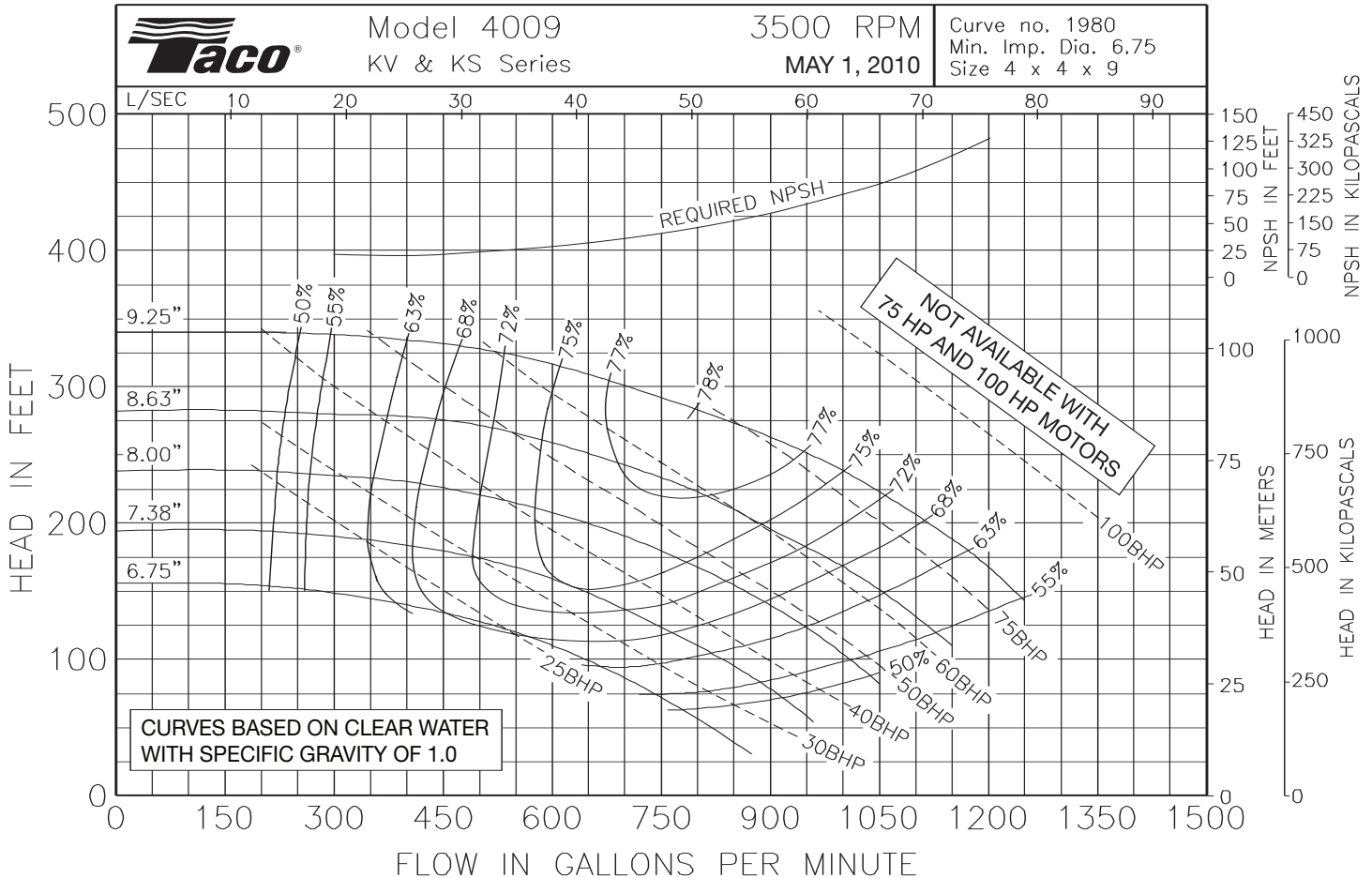

Comments:

Do it Once. Do it Right.®

TACO, INC., 1160 Cranston Street, Cranston, RI 02920 Telephone: (401) 942-8000 FAX: (401) 942-2360.
TACO (Canada), Ltd., 8450 Lawson Road, Unit #3, Milton, Ontario L9T 0J8. Telephone: 905/564-9422. FAX: 905/564-9436.
 Visit our web site at: <http://www.taco-hvac.com>

Printed in USA
 Copyright 2010
 TACO, Inc.