



Submittal Data Information

FI Series Pumps

301-1482

EFFECTIVE: MARCH 1, 2010

SUPERSEDES: OCTOBER 1, 2009

1160 RPM MODEL 4009

JOB _____ ENGINEER _____

CONTRACTOR _____ REP. _____

ITEM NO.	MODEL NO.	IMPELLER DIA.	G.P.M.	HEAD/FT.	H.P.	ELEC. CHAR.

WEIGHT _____ PUMP/MOTOR _____

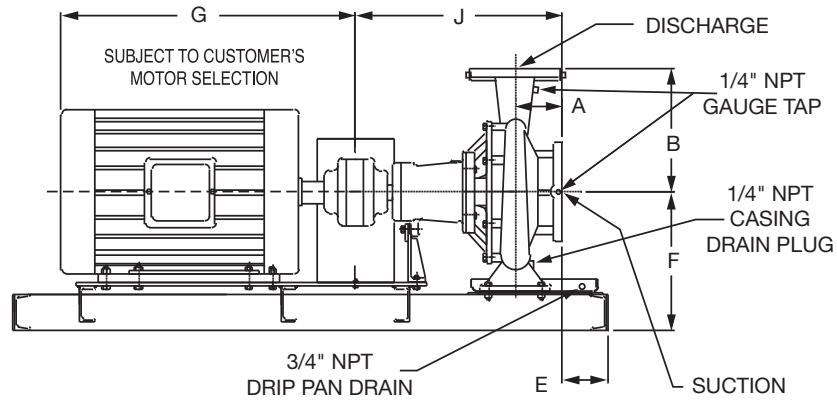
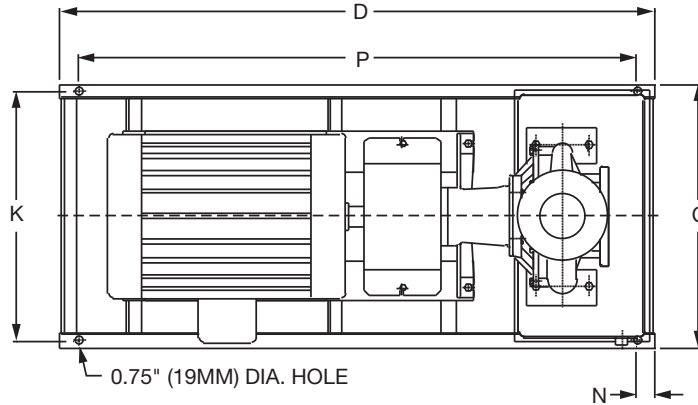

DIMENSIONS

50 Cycle Performance Curves attached when applicable.

Model No. Flange Size (Suction x Discharge)	Motor Frame	HP 1160 (RPM)	A		B		C	D	E		F	G	J		K	N	P			
			ANSI Class 125	ANSI Class 250	ANSI Class 125	ANSI Class 250			ANSI Class 125	ANSI Class 250			ANSI Class 125	ANSI Class 250						
4009 5 x 4 (127 x 120)	213T	3	5.31 (135)	5.75 (146)	12.50 (317)	12.81 (325)	19.17 (487)	52.0 (1321)	2.38 (60)	1.94 (49)	13.05 (331)	17.94 (456)	24.53 (623)	24.96 (634)	17.67 (449)	2.00 (51)	48.0 (1219)			
	215T	5																18.19 (462)	17.67 (449)	48.0 (1219)
	254T	7.5																21.69 (551)	17.67 (449)	48.0 (1219)

English dimensions are in inches. Metric dimensions are in millimeters. Metric data is presented in ().
Do not use for construction purposes unless certified.

MATERIALS OF CONSTRUCTION

Item	BRONZE FITTED		ALL IRON	
	Std. Pump Constr.	Optional	Standard	Optional
Casing	Cast Iron ASTM A48 Class 30A	N/A	Cast Iron ASTM A48 Class 30A	N/A
Impeller	Bronze ASTM B584-836	N/A	Cast Iron ASTM A48 Class 30A	N/A
Wear Ring	N/A	Bronze ASTM B584-932 SAE660	N/A	N/A
Shaft	Carbon Steel AISI 1045	St. Steel AISI 416 ASTM A582	Carbon Steel AISI 1045	St. Steel AISI 416 ASTM A582
Shaft Sleeve	Bronze ASTM B584-932 SAE660	St. Steel AISI 303 ASTM A276	St. Steel AISI 303 ASTM A276	N/A
Mech. Seal	Ceramic/ EPT	CF	Ceramic/ EPT	CF
Seal Flush Line	N/A	Copper	N/A	Stainless Steel

CF - Consult Factory

N/A - Not Available

OPERATING SPECIFICATIONS

	Standard	Optional
Flange	ANSI Class 125	ANSI Class 250
Pressure	175 PSIG* (1210 KPA)	300 PSIG** (2070 KPA)
Temperature	250°F (120°C)	250°F (120°C)

Motors: All NEMA Standard (T Frame)
 * In accordance with ANSI Standard B16.1 Class 125
 ** In accordance with ANSI Standard B16.1 Class 250 Dim.

MAXIMUM ASSEMBLY WEIGHT

Motor Frame	Weight Lbs (Kg)
213T - 215T	544 (247)
254T - 256T	649 (294)

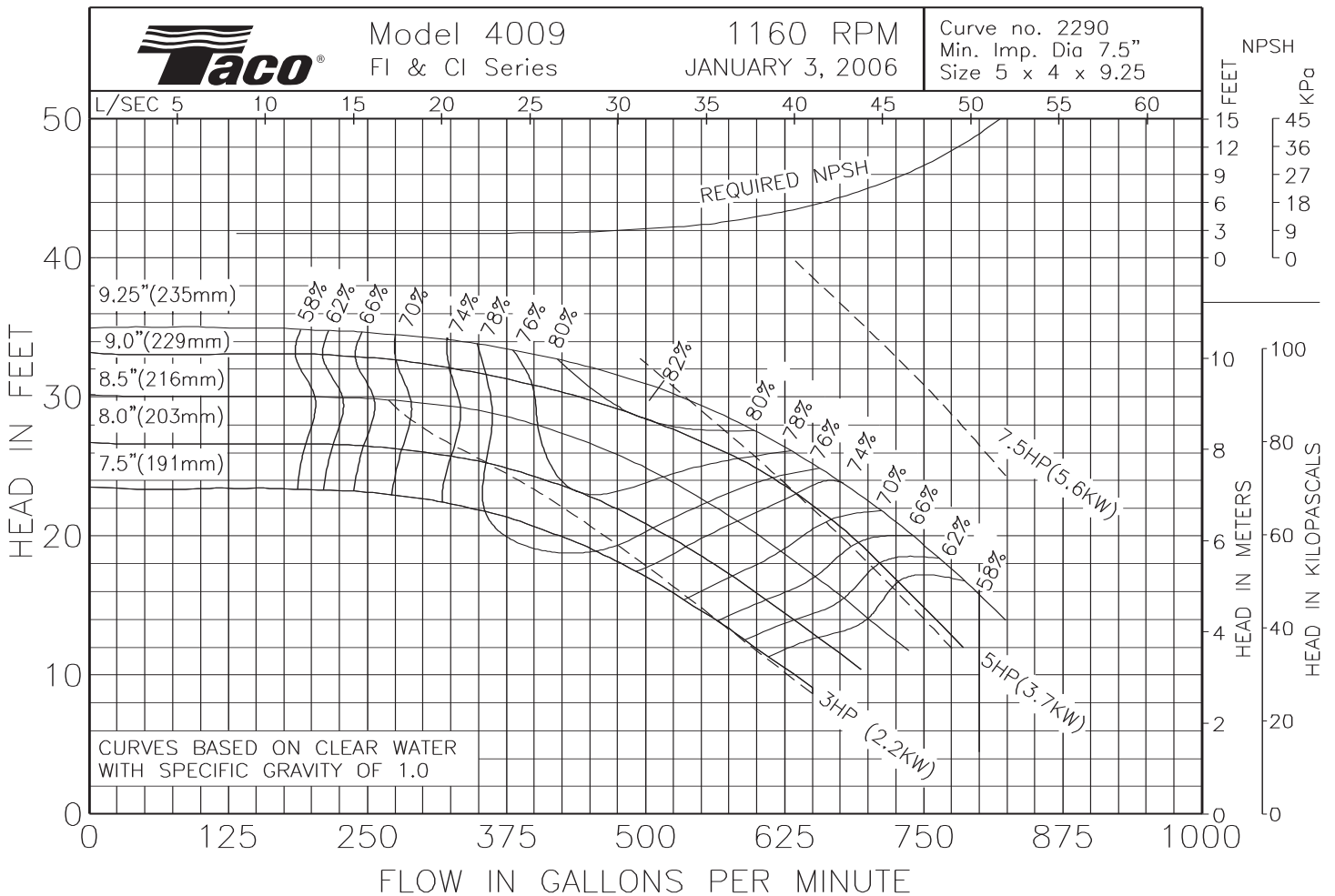

Comments:

Do it Once. Do it Right.®

TACO, INC., 1160 Cranston Street, Cranston, RI 02920 Telephone: (401) 942-8000 FAX: (401) 942-2360.
TACO (Canada), Ltd., 8450 Lawson Road, Unit #3, Milton, Ontario L9T 0J8. Telephone: 905/564-9422. FAX: 905/564-9436.
 Visit our web site at: <http://www.taco-hvac.com>

Printed in USA
 Copyright 2010
 TACO, Inc.



Submittal Data Information

FI Series Pumps

301-1483

EFFECTIVE: NOVEMBER 1, 2010

SUPERSEDES: MARCH 1, 2010

1760 RPM MODEL 4009

JOB _____ ENGINEER _____

CONTRACTOR _____ REP. _____

ITEM NO.	MODEL NO.	IMPELLER DIA.	G.P.M.	HEAD/FT.	H.P.	ELEC. CHAR.

WEIGHT _____ PUMP/MOTOR _____

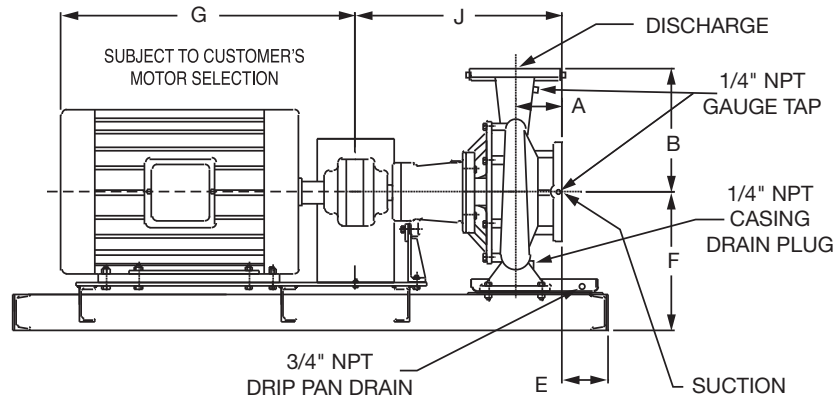
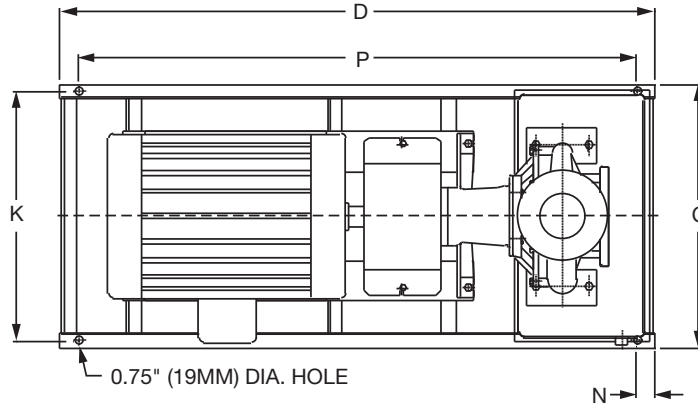

DIMENSIONS

50 Cycle Performance Curves attached when applicable.

Model No. Flange Size (Suction x Discharge)	Motor Frame	HP 1760 (RPM)	A		B		C	D	E		F	G	J		K	N	P
			ANSI Class 125	ANSI Class 250	ANSI Class 125	ANSI Class 250			ANSI Class 125	ANSI Class 250			ANSI Class 125	ANSI Class 250			
4009 5 x 4 (127 x 102)	215T	10	5.31 (135)	5.75 (146)	12.50 (317)	12.81 (325)	19.17 (487)	52.0 (1321)	2.38 (60)	1.94 (49)	13.05 (331)	18.19 (462)	24.53 (623)	24.96 (634)	17.67 (449)	2.00 (51)	48.0 (1219)
	254T	15					19.17 (487)	52.0 (1321)	2.38 (60)	1.94 (49)		21.69 (551)			17.67 (449)		48.0 (1219)
	256T	20					19.17 (487)	52.0 (1321)	2.38 (60)	1.94 (49)		23.19 (589)			17.67 (449)		48.0 (1219)
	284T	25					19.17 (487)	52.0 (1321)	2.38 (60)	1.94 (49)		24.94 (633)			17.67 (449)		48.0 (1219)

English dimensions are in inches. Metric dimensions are in millimeters. Metric data is presented in ().
Do not use for construction purposes unless certified.

MATERIALS OF CONSTRUCTION

Item	BRONZE FITTED		ALL IRON	
	Std. Pump Constr.	Optional	Standard	Optional
Casing	Cast Iron ASTM A48 Class 30A	N/A	Cast Iron ASTM A48 Class 30A	N/A
Impeller	Bronze ASTM B584-836	N/A	Cast Iron ASTM A48 Class 30A	N/A
Wear Ring	N/A	Bronze ASTM B584-932 SAE660	N/A	N/A
Shaft	Carbon Steel AISI 1045	St. Steel AISI 416 ASTM A582	Carbon Steel AISI 1045	St. Steel AISI 416 ASTM A582
Shaft Sleeve	Bronze ASTM B584-932 SAE660	St. Steel AISI 303 ASTM A276	St. Steel AISI 303 ASTM A276	N/A
Mech. Seal	Ceramic/ EPT	CF	Ceramic/ EPT	CF
Seal Flush Line	N/A	Copper	N/A	Stainless Steel

CF - Consult Factory

N/A - Not Available

OPERATING SPECIFICATIONS

	Standard	Optional
Flange	ANSI Class 125	ANSI Class 250
Pressure	175 PSIG* (1210 KPA)	300 PSIG** (2070 KPA)
Temperature	250°F (120°C)	250°F (120°C)

Motors: All NEMA Standard (T Frame)
 * In accordance with ANSI Standard B16.1 Class 125
 ** In accordance with ANSI Standard B16.1 Class 250 Dim.

MAXIMUM ASSEMBLY WEIGHT

Motor Frame	Weight Lbs (Kg)
213T - 215T	555 (252)
254T - 256T	637 (289)
284T - 286T	783 (355)

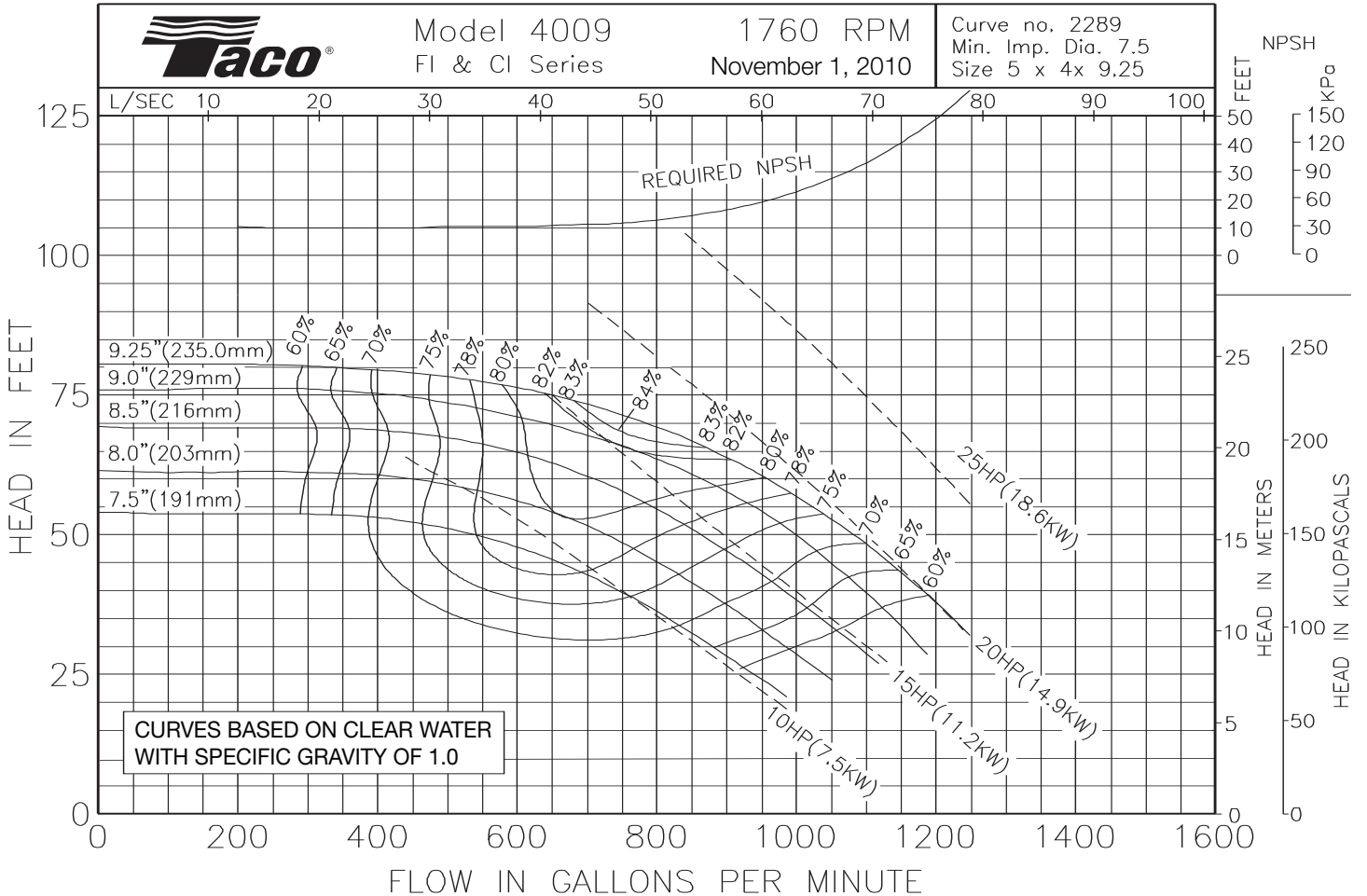

Comments:

Do it Once. Do it Right.®

TACO, INC., 1160 Cranston Street, Cranston, RI 02920 Telephone: (401) 942-8000 FAX: (401) 942-2360.
 TACO (Canada), Ltd., 8450 Lawson Road, Unit #3, Milton, Ontario L9T 0J8. Telephone: 905/564-9422. FAX: 905/564-9436.
 Visit our web site at: <http://www.taco-hvac.com>

Printed in USA
 Copyright 2010
 TACO, Inc.