



# Submittal Data Information

## CI Series Pumps

301-1315

EFFECTIVE: JANUARY 31, 2004

SUPERSEDES: FEBRUARY 28, 2003

1160 RPM MODEL 3007

JOB \_\_\_\_\_ ENGINEER \_\_\_\_\_ CONTRACTOR \_\_\_\_\_ REP. \_\_\_\_\_

ITEM NO.	MODEL NO.	IMPELLER DIA.	G.P.M.	HEAD/FT.	H.P.	ELEC. CHAR.
----------	-----------	---------------	--------	----------	------	-------------

WEIGHT \_\_\_\_\_ PUMP/MOTOR \_\_\_\_\_

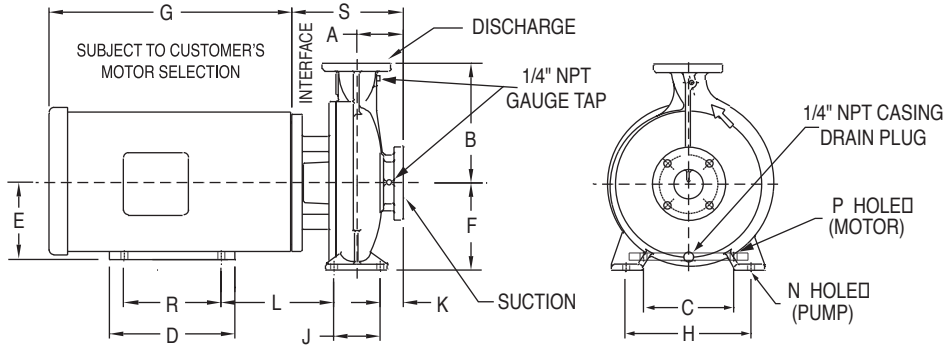

Model No.	HP	A	B	K	S
Flange Size (Suction x Discharge)	1160 (RPM)	250 PSI	250 PSI	250 PSI	250 PSI
3007 4 x 3 (102 x 76)	0.75	5.04 (128)	10.37 (263)	3.16 (80)	9.67 (245)
	1				
	1.5				
	2				

50 Cycle Performance Curves attached when applicable.

Model No. (Suction x Discharge)	Motor Frame	HP 1160 (RPM)	A 125 PSI	B 125 PSI	C (Motor)	D	E	F	G	H (Pump)	J	K 125 PSI	L	N (Pump)	P	R	S 125 PSI
3007 4 x 3 (102 x 76)	143JM	0.75	4.72 (120)	10.00 (254)	5.5 (140)	5.94 (151)	3.5 (89)	7.09 (180)	10.00 (254)	9.84 (250)	3.76 (96)	2.84 (72)	5.62 (143)	0.63 (16)	0.34 (9)	4.0 (101)	9.35 (237)
	145JM	1			5.5 (140)	5.94 (151)	3.5 (89)		10.00 (254)				5.62 (143)		0.34 (9)	5.0 (127)	
	182JM	1.5			7.5 (191)	6.50 (165)	4.5 (114)		12.25 (311)				0.41 (10)		4.5 (114)		
	184JM	2			7.5 (191)	6.50 (165)	4.5 (114)		12.25 (311)				0.41 (10)		5.5 (140)		

English dimensions are in inches. Metric dimensions are in millimeters. Metric data is presented in ( ). Do not use for construction purposes unless certified.

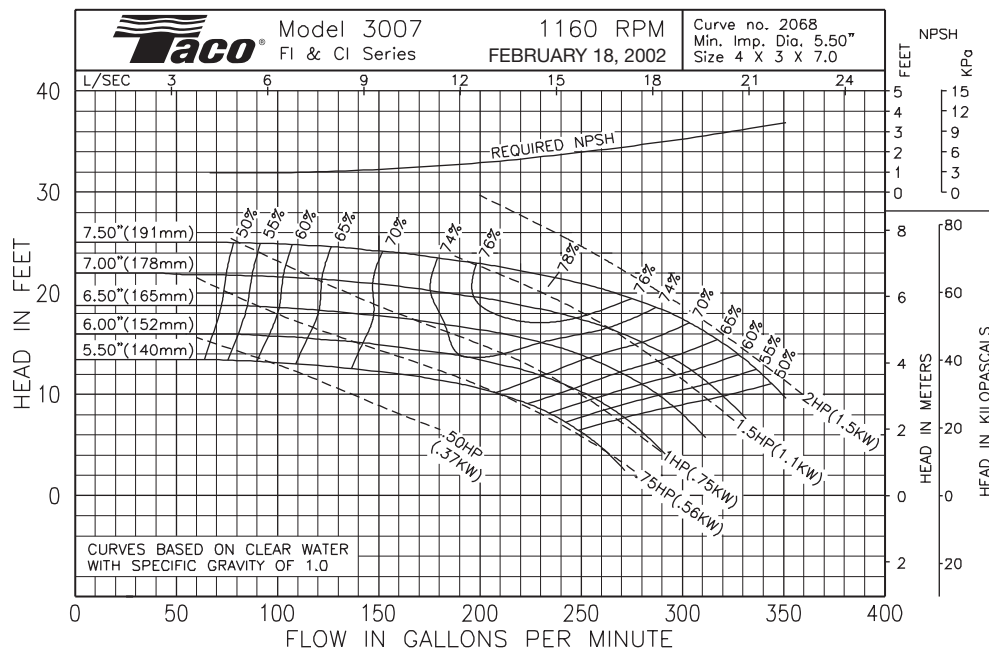

Item	BRONZE FITTED		ALL IRON	
	Std. Pump Constr.	Optional	Standard	Optional
Casing	Cast Iron ASTM A48 Class 30A	N/A	Cast Iron ASTM A48 Class 30A	N/A
Impeller	Bronze ASTM B584-836	N/A	Cast Iron ASTM A48 Class 30A	N/A
Wear Ring	N/A	Bronze ASTM B584-932 SAE660	N/A	N/A
Shaft	Carbon Steel AISI 1045	St. Steel AISI 416 ASTM A582	Carbon Steel AISI 1045	St. Steel AISI 416 ASTM A582
Shaft Sleeve	Bronze ASTM B584-932 SAE660	St. Steel AISI 303 ASTM A276	St. Steel AISI 303 ASTM A276	N/A
Mech. Seal	Ceramic/EPT	CF	Ceramic/EPT	CF
Seal Flush Line	Copper	CF	Stainless Steel	CF

OPERATING SPECIFICATIONS		
	Standard	Optional
Flange	125# 860K	250# 1720K
Pressure	175 PSIG* 1210 KPA	300 PSIG** 2070 KPA
Temperature	250°F 120°C	250°F 120°C

Motors: All NEMA Standard (JM Frame)  
 \* In accordance with ANSI Standard B16.1 Class 125  
 \*\* In accordance with ANSI Standard B16.1 Class 250 Dim.  
 CF - Consult Factory N/A - Not Available

Comments: \_\_\_\_\_

**TACO, INC.**, 1160 Cranston Street, Cranston, RI 02920 Telephone: (401) 942-8000 FAX: (401) 942-2360.

**TACO (Canada), Ltd.**, 6180 Ordan Drive, Mississauga, Ontario L5T 2B3. Telephone: 905/564-9422. FAX: 905/564-9436.

Printed in USA  
 Copyright 2004  
 TACO, INC.



# Submittal Data Information CI Series Pumps

301-1316

EFFECTIVE: NOVEMBER 1, 2010

SUPERSEDES: NOVEMBER 1, 2009

1760 RPM MODEL 3007

JOB \_\_\_\_\_ ENGINEER \_\_\_\_\_

CONTRACTOR \_\_\_\_\_ REP. \_\_\_\_\_

ITEM NO.	MODEL NO.	IMPELLER DIA.	G.P.M.	HEAD/FT.	H.P.	ELEC. CHAR.
----------	-----------	---------------	--------	----------	------	-------------

WEIGHT \_\_\_\_\_ PUMP/MOTOR \_\_\_\_\_

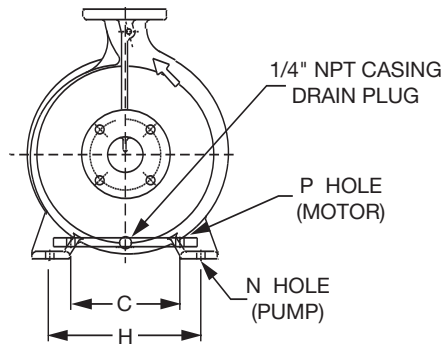
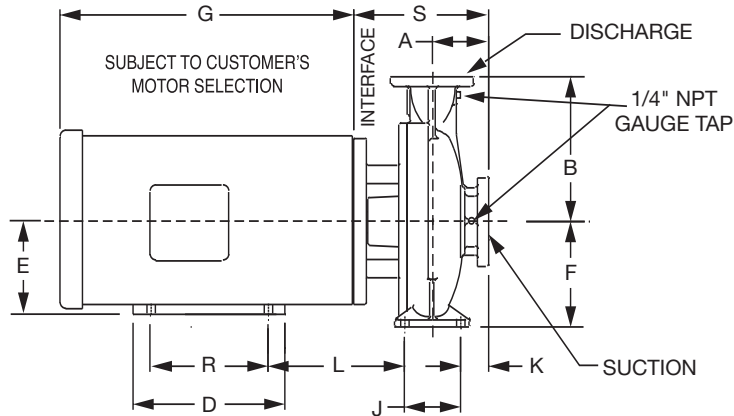

### DIMENSIONS (250 PSI)

Model No. Flange Size (Suction x Discharge)	HP 1760 (RPM)	A ANSI Class 250	B ANSI Class 250	K ANSI Class 250	S ANSI Class 250
3007 4 x 3 (102 x 76)	2	5.04 (128)	10.37 (263)	3.16 (80)	9.67 (245)
	3				
	5				
	7.5				

### DIMENSIONS

50 Cycle Performance Curves attached when applicable.

Model No. Flange Size (Suction x Discharge)	Motor Frame	HP 1760 (RPM)	A ANSI Class 125	B ANSI Class 125	C (Motor)	D	E	F	G	H (Pump)	J	K ANSI Class 125	L	N (Pump)	P	R	S ANSI Class 125
3007 4 x 3 (102 x 76)	145JM	2	4.72 (120)	10.00 (254)	5.5 (140)	5.94 (151)	3.50 (89)	7.09 (180)	10.00 (254)	9.84 (250)	3.76 (96)	2.84 (72)	5.62 (143)	0.63 (16)	0.34 (9)	5.0 (127)	9.35 (237)
	182JM	3			7.5 (191)	6.50 (165)	4.50 (114)		12.25 (311)				6.25 (159)		0.41 (10)	4.5 (114)	
	184JM	5			7.5 (191)	6.50 (165)	4.50 (114)		12.25 (311)				6.25 (159)		0.41 (10)	5.5 (140)	
	213JM	7.5			8.5 (216)	8.00 (203)	5.25 (133)		13.94 (354)				7.25 (184)		0.41 (10)	5.5 (140)	

English dimensions are in inches. Metric dimensions are in millimeters. Metric data is presented in ( ).  
Do not use for construction purposes unless certified.

**MATERIALS OF CONSTRUCTION**

Item	BRONZE FITTED		ALL IRON	
	Std. Pump Constr.	Optional	Standard	Optional
Casing	Cast Iron ASTM A48 Class 30A	N/A	Cast Iron ASTM A48 Class 30A	N/A
Impeller	Bronze ASTM B584-836	N/A	Cast Iron ASTM A48 Class 30A	N/A
Wear Ring	N/A	Bronze ASTM B584-932 SAE660	N/A	N/A
Shaft	Carbon Steel AISI 1045	St. Steel AISI 416 ASTM A582	Carbon Steel AISI 1045	St. Steel AISI 416 ASTM A582
Shaft Sleeve	Bronze ASTM B584-932 SAE660	St. Steel AISI 303 ASTM A276	St. Steel AISI 303 ASTM A276	N/A
Mech. Seal	Ceramic/EPT	CF	Ceramic/EPT	CF
Seal Flush Line	N/A	Copper	N/A	Stainless Steel

CF - Consult Factory

N/A - Not Available

**OPERATING SPECIFICATIONS**

	Standard	Optional
Flange	ANSI Class 125	ANSI Class 250
Pressure	175 PSIG* (1210 KPA)	300 PSIG** (2070 KPA)
Temperature	250°F (120°C)	250°F (120°C)

Motors: All NEMA Standard (T Frame)  
 \* In accordance with ANSI Standard B16.1 Class 125  
 \*\* In accordance with ANSI Standard B16.1 Class 250 Dim.

**MAXIMUM ASSEMBLY WEIGHT**

Motor Frame	Weight Lbs (Kg)
143JM - 145JM	143 (65)
182JM - 184JM	183 (83)
213JM - 215JM	240 (109)

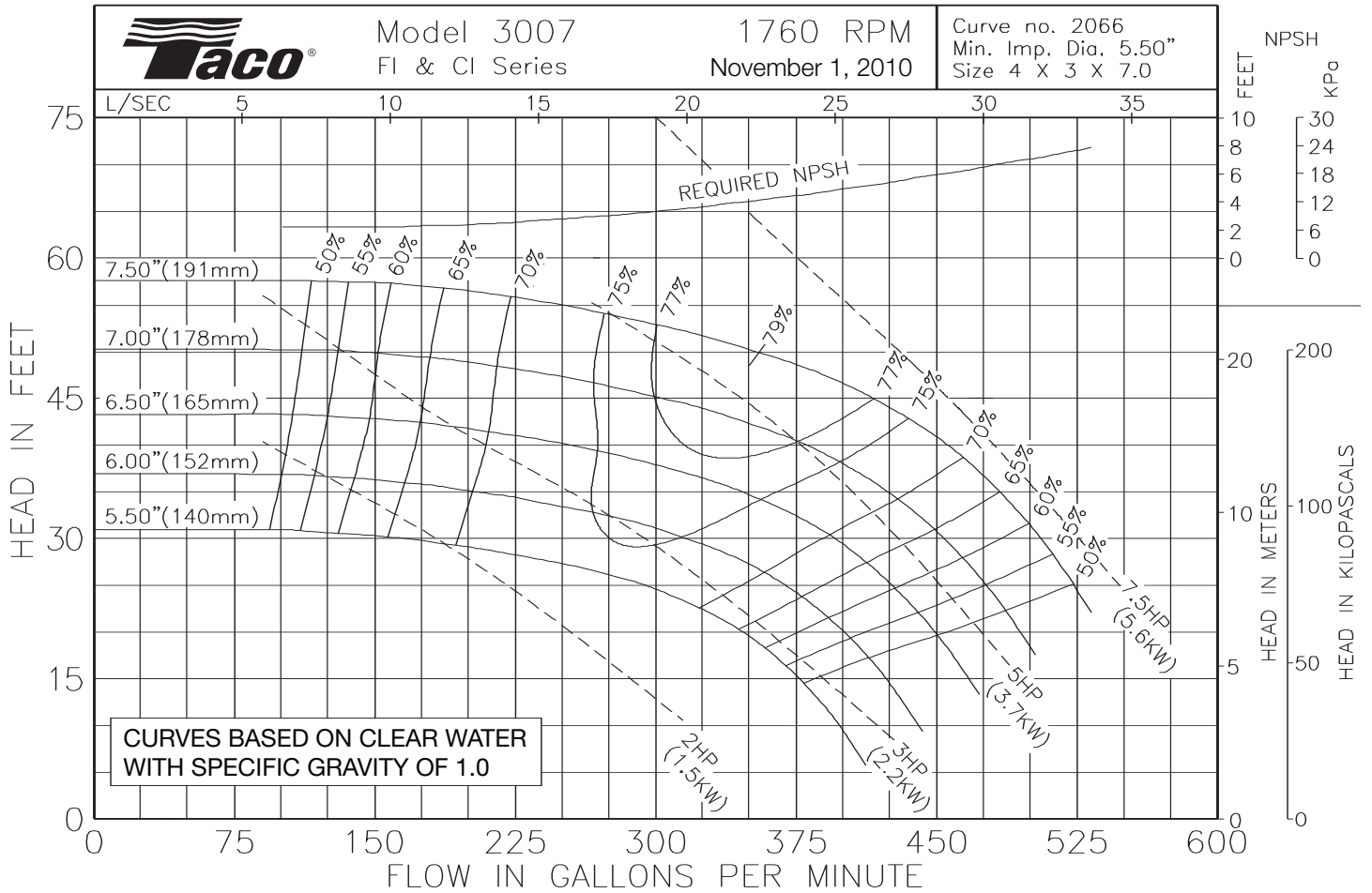

Comments:

**Do it Once. Do it Right.®**

TACO, INC., 1160 Cranston Street, Cranston, RI 02920 Telephone: (401) 942-8000 FAX: (401) 942-2360.  
 TACO (Canada), Ltd., 8450 Lawson Road, Unit #3, Milton, Ontario L9T 0J8. Telephone: 905/564-9422. FAX: 905/564-9436.

Visit our web site at: <http://www.taco-hvac.com>

Printed in USA  
 Copyright 2010  
 TACO, Inc.



# Submittal Data Information CI Series Pumps

301-1317

EFFECTIVE: NOVEMBER 1, 2009

SUPERSEDES: JANUARY 31, 2004

3500 RPM MODEL 3007

JOB \_\_\_\_\_ ENGINEER \_\_\_\_\_

CONTRACTOR \_\_\_\_\_ REP. \_\_\_\_\_

ITEM NO.	MODEL NO.	IMPELLER DIA.	G.P.M.	HEAD/FT.	H.P.	ELEC. CHAR.
----------	-----------	---------------	--------	----------	------	-------------

WEIGHT \_\_\_\_\_ PUMP/MOTOR \_\_\_\_\_

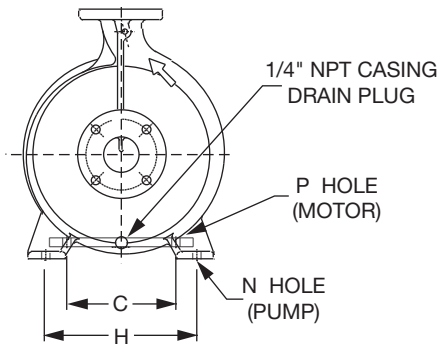
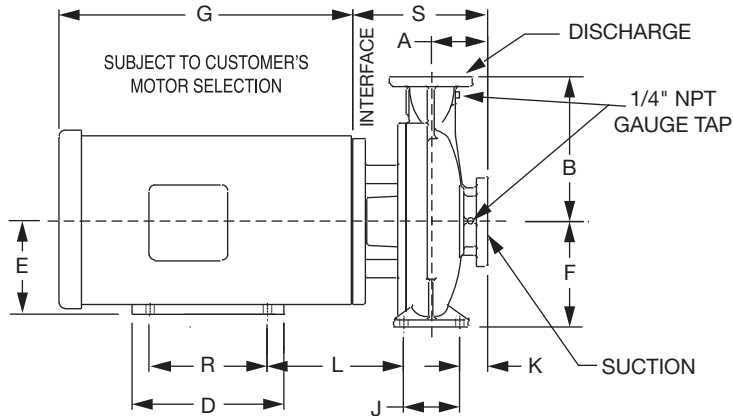

### DIMENSIONS (250 PSI)

Model No. Flange Size (Suction x Discharge)	HP 3500 (RPM)	A ANSI Class 250	B ANSI Class 250	K ANSI Class 250	S ANSI Class 250
3007 4 x 3 (102 x 76)	20	5.04 (128)	10.37 (263)	3.16 (80)	10.75 (273)
	25				
	30				
	40				
	50				
60					

### DIMENSIONS

50 Cycle Performance Curves attached when applicable.

Model No. Flange Size (Suction x Discharge)	Motor Frame	HP 3500 (RPM)	A ANSI Class 125	B ANSI Class 125	C (Motor)	D	E	F	G	H (Pump)	J	K ANSI Class 125	L	N (Pump)	P	R	S ANSI Class 125
3007 4 x 3 (102 x 76)	254JM	20	4.72 (120)	10.00 (254)	10.0 (254)	9.50 (241)	6.25 (159)	7.09 (180)	16.19 (411)	9.84 (250)	3.76 (96)	2.84 (72)	8.83 (224)	0.63 (16)	0.53 (13)	8.25 (210)	10.43 (265)
	256JM	25			10.0 (254)	11.75 (298)	6.25 (159)		16.19 (411)				8.83 (224)		0.53 (13)	10.00 (254)	
	284JM	30			11.0 (279)	10.75 (273)	7.00 (178)		19.81 (503)				8.83 (224)		0.53 (13)	9.50 (241)	
	286JM	40			11.0 (279)	12.25 (311)	7.00 (178)		19.81 (503)				8.83 (224)		0.53 (13)	11.00 (279)	
	324JM	50			12.5 (318)	12.00 (305)	8.00 (203)		23.44 (595)				9.33 (237)		0.66 (17)	10.50 (267)	
	326JM	60 *			12.5 (318)	13.50 (343)	8.00 (203)		23.44 (595)				9.33 (237)		0.66 (17)	12.00 (305)	

English dimensions are in inches. Metric dimensions are in millimeters. Metric data is presented in ( ).

Do not use for construction purposes unless certified.

\* 60 HP not available in TEFC.

**MATERIALS OF CONSTRUCTION**

Item	BRONZE FITTED		ALL IRON	
	Std. Pump Constr.	Optional	Standard	Optional
Casing	Cast Iron ASTM A48 Class 30A	N/A	Cast Iron ASTM A48 Class 30A	N/A
Impeller	Bronze ASTM B584-836	N/A	Cast Iron ASTM A48 Class 30A	N/A
Wear Ring	N/A	Bronze ASTM B584-932 SAE660	N/A	N/A
Shaft	Carbon Steel AISI 1045	St. Steel AISI 416 ASTM A582	Carbon Steel AISI 1045	St. Steel AISI 416 ASTM A582
Shaft Sleeve	Bronze ASTM B584-932 SAE660	St. Steel AISI 303 ASTM A276	St. Steel AISI 303 ASTM A276	N/A
Mech. Seal	Ceramic/EPT	CF	Ceramic/EPT	CF
Seal Flush Line	N/A	Copper	N/A	Stainless Steel

CF - Consult Factory

N/A - Not Available

**OPERATING SPECIFICATIONS**

	Standard	Optional
Flange	ANSI Class 125	ANSI Class 250
Pressure	175 PSIG* (1210 KPA)	300 PSIG** (2070 KPA)
Temperature	250°F (120°C)	250°F (120°C)

Motors: All NEMA Standard (T Frame)  
 \* In accordance with ANSI Standard B16.1 Class 125  
 \*\* In accordance with ANSI Standard B16.1 Class 250 Dim.

**MAXIMUM ASSEMBLY WEIGHT**

Motor Frame	Weight Lbs (Kg)
254JM - 256JM	524 (238)
284JM - 286JM	638 (289)
324JM - 326JM	789 (358)

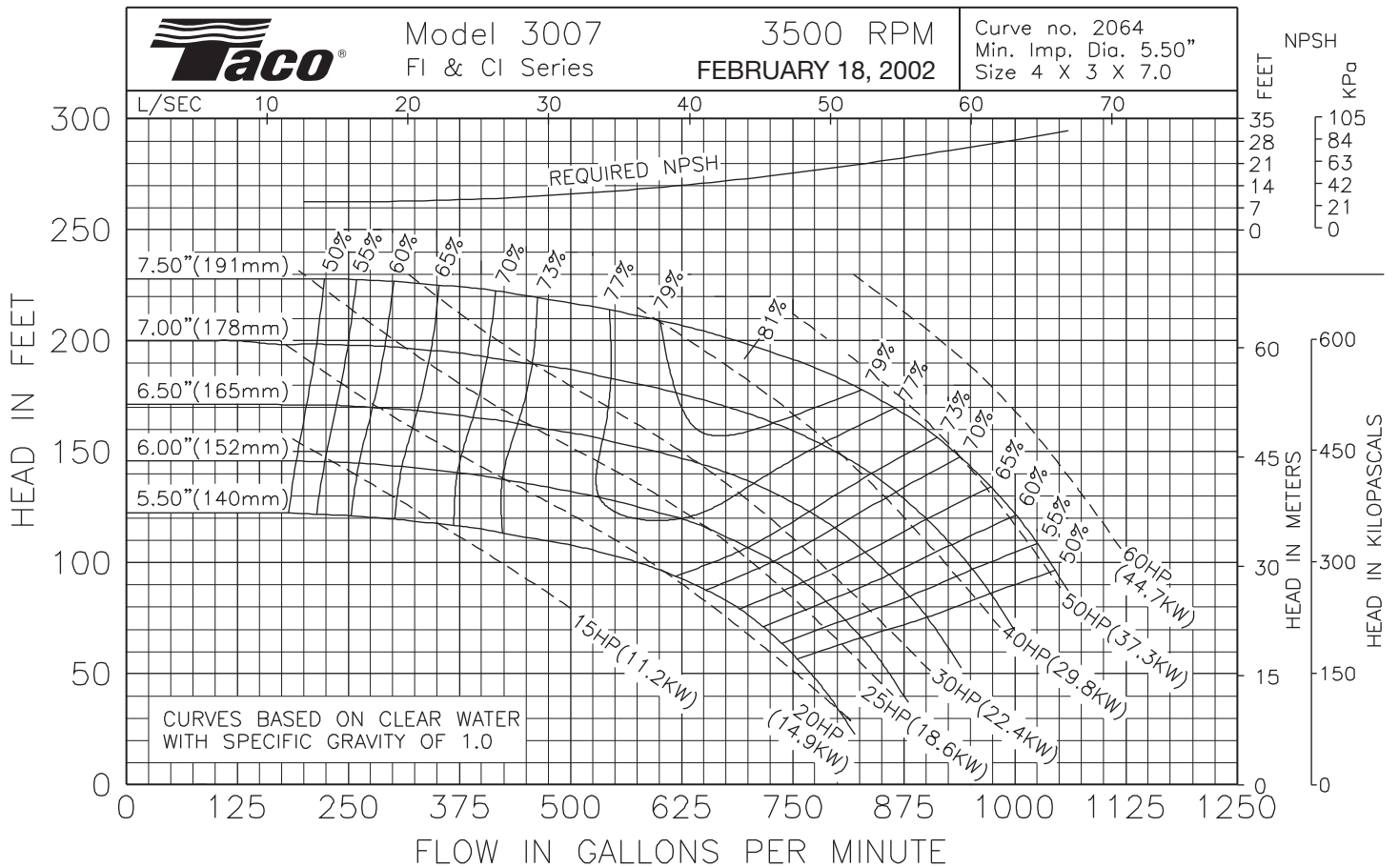

Comments:

**Do it Once. Do it Right.®**

**TACO, INC.**, 1160 Cranston Street, Cranston, RI 02920 Telephone: (401) 942-8000 FAX: (401) 942-2360.  
**TACO (Canada), Ltd.**, 8450 Lawson Road, Unit #3, Milton, Ontario L9T 0J8. Telephone: 905/564-9422. FAX: 905/564-9436.  
 Visit our web site at: <http://www.taco-hvac.com>

Printed in USA  
 Copyright 2009  
 TACO, Inc.