

Series 4300 Vertical in-line

Equal suction & discharge 'L' designation

Parts list

TC/TSC/TCZ motors only,
groups 21 to 24

1⁵/₈" impeller bore
2¹/₈" mechanical seal or
packing gland

File No: 6043.136
Date: NOVEMBER 09, 2015
Supersedes: 6043.136
Date: MARCH 15, 2005

MODEL 4300 - VERTICAL PUMP - SPLIT COUPLING TC MOTORS - SINGLE SUCTION
 GROUPS 21 TO 24 SELECTION CHART (L) 1½" IMPELLER HUB

PUMP SIZE	GROUP NUMBER	MOTOR FRAME									
		143 145	182 184	FT215 213 215	254 256	284 286	324 326	FF300/FF350 364 365	404 405	444 445	447 449
10×10×13	22	—	—	—	—	—	—	TC	—	—	—
	23	—	—	—	—	—	—	—	TC	—	—
	24	—	—	—	—	—	—	—	—	TC	TC
8×8×15	21	—	—	—	—	—	TC	—	—	—	—
	22	—	—	—	—	—	—	TC	—	—	—
	23	—	—	—	—	—	—	—	TC	—	—
	24	—	—	—	—	—	—	—	—	TC	TC
10×10×15	21	—	—	—	—	—	TC	—	—	—	—
	22	—	—	—	—	—	—	TC	—	—	—
	23	—	—	—	—	—	—	—	TC	—	—
	24	—	—	—	—	—	—	—	—	TC	TC

4300 GROUP NUMBER		21	22	23	24
SEAL SIZE AND PUMP SHAFT DIAMETER		2½	2½	2½	2½
IMPELLER BORE		1½	1½	1½	1½
COUPLING BORE	MOTOR SHAFT DIAMETER	2½	2¾	2⅞	3⅞
	PUMP SHAFT DIAMETER	2½	2½	2½	1½
SHAFT GAP BETWEEN PUMP AND MOTOR		1¾	1¾	2½	1¾

Cross section view

Groups 5,6,7,8,9 & 10

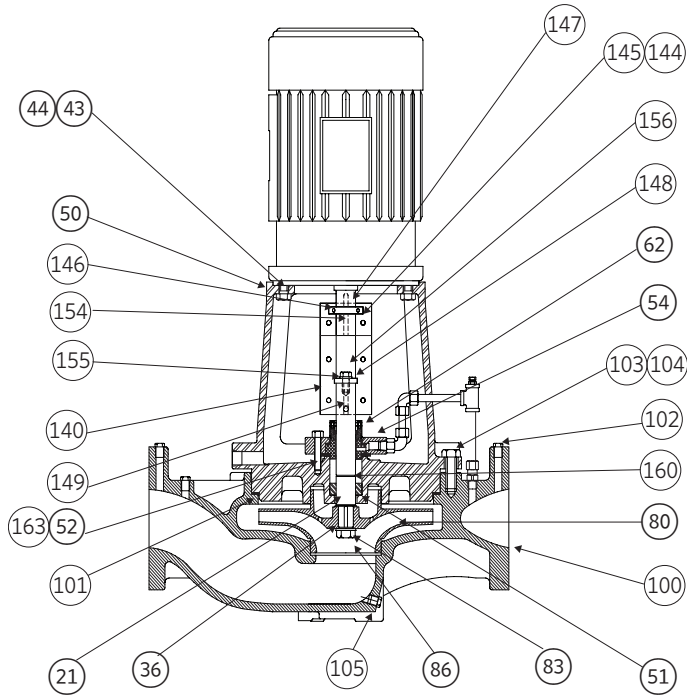

MECHANICAL SEAL

Exploded view

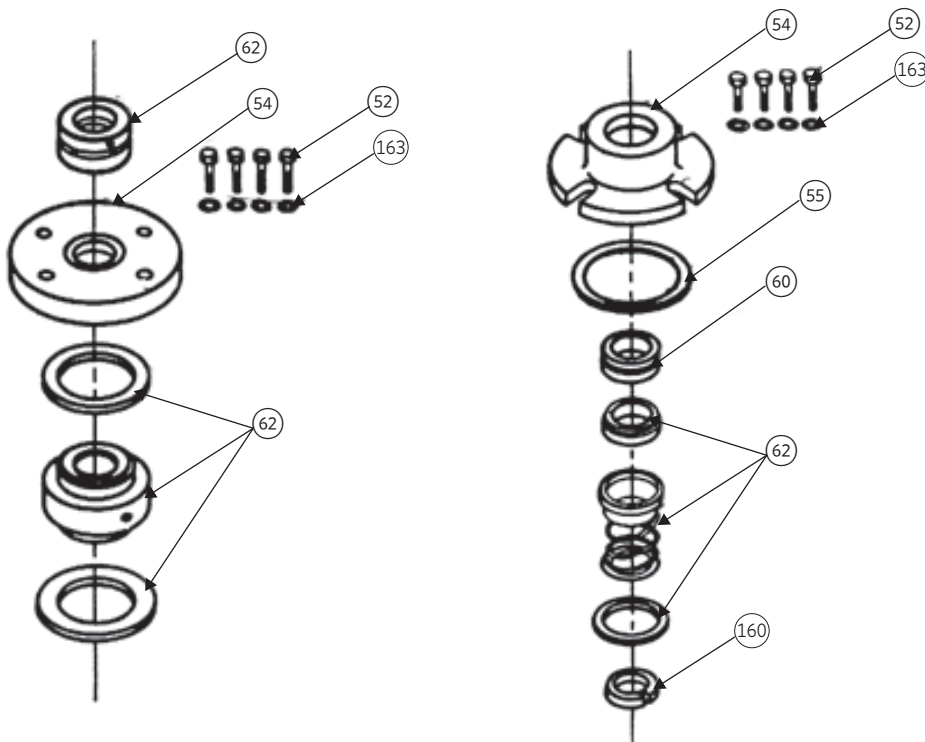

OUTSIDE MECHANICAL SEAL

INSIDE MECHANICAL SEAL

INDEX

ITEM	DESCRIPTION	PAGE
21	Shaft	11
36	Impeller key	11
43	Lockwasher	9
44	Motor capscrew	9
50	Stuffing box/adapter	7&8
51	Seal chamber bushing	11
52	Seal cover capscrew	11
54	Seal cover	11
55	Inside seal cover gasket	12
57	Male straight connector	13
59	Tubing	13
60	Inside seal seat	12
62	Outside mechanical seal Armstrong STD.	11
62	Outside mechanical seal John crane STD.	11
62	Outside mechanical seal John crane T.C.	11
62	Outside mechanical seal Durametallc STD.	11
62	Outside mechanical seal Durametallc T.C.	11
62	Inside mechanical seal head B.F. & A.I. construction	12
63	¼" NPT tee	13
68	Air vent	13
80	Impeller	5
83	Impeller washer	11
86	Impeller Acorn nut	11

ITEM	DESCRIPTION	PAGE
90	Case wear ring	6
100	Casing	5
101	Casing gasket	6
103	Casing capscrew washer	9
104	Casing capscrew	9
105	Casing drain plug	5
140	Coupler	10
144	Coupler capscrew	11
145	Lockwasher	11
146	Coupler collar set screw	11
147	Motor shaft coupler collar	10
148	Pump shaft coupler collar	11
149	Coupler square key (pump)	11
150	Coupling guard (not shown)	6
151	Coupler guard bolt (not shown)	6
152	Nut (not shown)	6
153	Washer (not shown)	6
154	Coup. Square key (motor)	9
155	Capscrew lockwasher	11
156	Shaft capscrew	11
160	Inside seal retaining ring	12
163	Seal cover caps. washer	12
194	Male 90° angle connection	

ITEM 100 CASING**

PUMP SIZE	PRESSURE RATING (LB)	CONSTRUCTION	PART NUMBER
10×10×13	125#	Cast iron	427330-011
	250#	Ductile iron	427331-031
8×8×15	125#	Cast iron	427087-011
	250#	Ductile iron	427088-031
10×10×15	125#	Cast iron	427083-011
	250#	Ductile iron	427084-031

NOTES:

** Casing part numbers are for casing only, casing wear ring is sold separately.
 If new casing is required, it must be ordered c/w wear ring.

ITEM 105 CASING DRAIN PLUG

PUMP SIZE	MATERIAL	NUMBER REQUIRED	SIZE	PART NUMBER
10×10×13	CAD. PLATED	1	½" NPT	937105-203
8×8×15				
10×10×15				

ITEM 80 IMPELLER 1¼" BORE**

PUMP SIZE	MATERIAL	IMPELLER BORE	MAXIMUM DIAMETER	PART NUMBER
10×10×13	Bronze	1⅝"	13"	427333-041
	Cast iron	1⅝"	13"	427333-011
8×8×15	Bronze	1⅝"	15"	427214-041
	Cast iron	1⅝"	15"	427214-011
10×10×15	Bronze	1⅝"	15"	427218-041
	Cast iron	1⅝"	15"	427218-011

NOTES:

** Impeller part numbers are for full or maximum diameter Impellers. Always specify pump serial number and where possible, measure and advise the diameter of the Impeller being replaced on these pumps.

6

ITEM 90 CASE WEAR RING

PUMP SIZE	MATERIAL	CONSTRUCTION	PART NUMBER
10×10×13	SAE 660 BRONZE	All bronze, Bronze fitted	426413-417
10×10×15	CLASS 30 C.I.	All iron, Ductile iron	426413-117
8×8×15	SAE 660 BRONZE	All bronze, Bronze fitted	426413-415
	CLASS 30 C.I.	All iron, Ductile iron	426413-115

ITEM 101 CASING GASKET

PUMP SIZE	CONSTRUCTION	PART NUMBER
10×10×13	ALL	426401-005
8×8×15	ALL	426401-008
10×10×15	ALL	426401-008

ITEM 150 COUPLER GUARD

PUMP SIZE	MOTOR FRAME SIZE	PART NUMBER
10×10×13	324 - 326TC	427858-000
8×8×15		
10×10×15	364 - 365TC	
10×10×13	404 - 405TC	427860-000
8×8×15		
10×10×15	444/445/447/449TC	

COUPLER GUARD FASTENERS

ITEM NUMBER	DESCRIPTION	NUMBER REQUIRED	SIZE	PART NUMBER
151	Bolt - RD. HD.	2	#8-32×1 $\frac{1}{2}$ "	916262-132
152	Nut	2	#8-32	913162-100
153	Washer	2	#8-32	927105-100

ITEM 50 ADAPTER

Bronze fitted and All iron construction

PUMP SIZE	MOTOR FRAME SIZE	MATERIAL	PART NUMBER
10×10×13	363 – 366TSC	Cast iron	
	364 – 365TC		427843-011
	404 – 405TC		427845-011
	403 – 406TSC		
	444/445/447/449TC		427846-011
8×8×15	324 – 326TC	Cast iron	427842-011
	364 – 365TC		427842-011
10×10×15	404 – 405TC		427847-011
	444/445/447/449TC		427846-011

ITEM 50 PUMPS STUFFING BOX

Bronze fitted and All iron construction

PUMP SIZE	MOTOR FRAME SIZE	MATERIAL	PART NUMBER
10×10×13	ALL	Cast iron	427885-011
8×8×15	ALL	Cast iron	427886-011
10×10×15	ALL	Cast iron	427886-011

ITEM 150

13 & 15" motor adapter ring all constructions

PUMP SIZE	MOTOR FRAME SIZE	MATERIAL	PART NUMBER
All	364 – 365TC	Steel	427730-000

8

ITEM 50 ADAPTER

Ductile iron construction

PUMP SIZE	MOTOR FRAME SIZE	MATERIAL	PART NUMBER
10×10×13	363 – 366TSC	Cast iron	
	364 – 365TC		427843-011
	404 – 405TC		427845-011
	403 – 406TSC		
	444/445/447/449TC		427846-011
8×8×15	324 – 326TC	Cast iron	427842-011
	364 – 365TC		427842-011
10×10×15	404 – 405TC		427847-011
	444/445/447/449TC		427846-011

ITEM 50 PUMPS STUFFING BOX

Ductile iron construction

PUMP SIZE	MOTOR FRAME SIZE	MATERIAL	PART NUMBER
10×10×13	ALL	Ductile iron	427885-031
8×8×15	ALL	Ductile iron	427886-031
10×10×15	ALL	Ductile iron	427886-031

ITEM 150

13 & 15" motor adapter ring all constructions

PUMP SIZE	MOTOR FRAME SIZE	MATERIAL	PART NUMBER
All	364 – 365TC	Steel	427730-000

ITEM 44 MOTOR CAPSCREW & ITEM 43 LOCKWASHER

PUMP SIZE	MOTOR FRAME SIZE	ITEM DESCRIPTION	PART NUMBER
10×10×13	324-326TC	Capscrew	911129-112
8×8×15	404-405TC	Lockwasher	927215-100
10×10×15	444/445/447/449TC		

ITEM 104 CASING CAPSCREW & ITEM 103 WASHER

PUMP SIZE	NUMBER REQUIRED	DESCRIPTION	SIZE	PART NUMBER
10×10×13	16	Capscrew	5/8"-11NCX1¾"	911129-234
	16	Washer	5/8" FLAT	927121-100
8×8×15	16	Capscrew	5/8"-11NCX2"	911129-218
	16	Lockwasher	5/8"	927213-100
10×10×15	16	Washer	5/8" FLAT	927121-100

ITEM 154 MOTOR KEY

PUMP SIZE	MOTOR FRAME SIZE	PART NUMBER
8×8×15 10×10×15	324 - 326TC	428164-116
10×10×13 8×8×15 10×10×15	364 - 365TC	428165-117
10×10×13 8×8×15 10×10×15	404 - 405TC	428167-103
10×10×13 8×8×15 10×10×15	444/445/447/449TC	428167-305

10

ITEM 147 MOTOR COUPLER COLLAR

PUMP SIZE	MOTOR FRAME SIZE	PART NUMBER
8×8×15 10×10×15	324 - 326TC	427753-000
10×10×13 8×8×15 10×10×15	364 - 365TC	427754-000
10×10×13 8×8×15 10×10×15	404 - 405TC	427889-000
10×10×13 8×8×15 10×10×15	444/445/447/449TC	427883-000

ITEM 140 COUPLER

PUMP SIZE	MOTOR FRAME SIZE	PART NUMBER
8×8×15 10×10×15	324 - 326TC	427867-000
10×10×13 8×8×15 10×10×15	364 - 365TC	427868-000
10×10×13 8×8×15 10×10×15	404 - 405TC	427869-000
10×10×13 8×8×15 10×10×15	444/445/447/449TC	427870-000

COMMON PARTS

All constructions

ITEM NUMBER	DESCRIPTION	PART NUMBER
21	2½" Pump shaft	427849-000
36	Impeller key	428163-714
51	Seal chamber bushing	425520-003
83	Impeller washer	425742-006
86	Impeller acorn nut (brass)	425745-001
86	Impeller acorn nut (SST)	425745-002
102	Gauge plug (4 required) ¼" NPT. CAD plated	937105-201
144	Coupler capscrew (6 required) Frames 182 to 365TC and 324-446TSC	911821-118
145	Lockwasher (for item 144)	927211-100
148	Shaft coupler collar	427882-000
146	Coupler collar set screw	916519-106
149	Cplr. key (pump shaft)	428164-724
155	Capscrew lockwasher	927215-400
156	Coupler collar capscrew	911129-108

PARTS FOR 2½" OUTSIDE SEAL

ITEM NUMBER	DESCRIPTION	CONSTRUCTION	PART NUMBER
62	Mechanical seal		
	Armstrong seal	All	975002-374
	Durametallic STD.	All	975002-073
	Durametallic T.C.	All	975002-071
	John crane STD.	All	975000-957
	John crane T.C.	All	975000-967
52	Capscrew - 4 req'd ½"-13NCx2" S/S	All	911125-416
163	Washer - 4 req'd ½" FLAT 316 S/S	All	427118-100
54	Seal cover	Bronze fitted, Ductile bronze fitted	426486-002
		All iron, Ductile iron	426486-001

PARTS FOR 2½" INSIDE MECHANICAL SEAL ARRANGEMENT

ITEM NUMBER	DESCRIPTION	CONSTRUCTION	PART NUMBER
62	Mechanical seal	All	975001-577
60	Seal seat	All	975000-931
52	Capscrew - 4 required ½"-13NCx2" S/S	All	911125-416
163	Washer- 4 required ½" FLAT	All	427117-100
54	Seal cover	Bronze fitted, Ductile bronze fitted	426466-011
55	Seal cover gasket	All	426467-002
160	Retaining ring	All	927117-100

PARTS FOR 2½" PACKED GLAND ARRANGEMENT

ITEM NUMBER	DESCRIPTION	CONSTRUCTION	PART NUMBER
52	Studbolt - 2 required ½"-13NCx3" S/S	All	915225-424
53	Nut - 2 req'd ½"-13NC S/S	All	913125-400
163	Washer - 2 required ½" FLAT	All	426451-001
54	Split gland	All	426463-011
65	Packing - 5 required 2½"x¾" JC #1340	All	966302-001
66	Lantern ring	All	426451-005

COMMON PARTS FOR OUTSIDE AND INSIDE SEAL ARRANGEMENTS

ITEM NUMBER	DESCRIPTION	CONSTRUCTION	PART NUMBER
57	Male connector ¾" TUBE × ¼" NPT	Bronze fitted, Ductile bronze fitted	939001-114
		All iron, Ductile iron	939001-214
59	Tubing 24" required ¾" OD × .035 WALL	Bronze fitted, Ductile bronze fitted	997531-004
		All iron, Ductile iron	997153-004
63	TEE ¼" NPT	Bronze fitted, Ductile bronze fitted	935101-001
		All iron, Ductile iron	931101-101
64	Bushing ¼" × ⅛" NPT	Bronze fitted, Ductile bronze fitted	935123-050
		All iron, Ductile iron	931123-150
67	Nipple ¼" × 2½"	Bronze fitted, Ductile bronze fitted	938103-001
		All iron, Ductile iron	938003-101
68	Air release valve	Bronze fitted, Ductile bronze fitted	939018-101
		All iron, Ductile iron	218644-000

TORONTO

23 BERTRAND AVENUE
TORONTO, ONTARIO
CANADA
M1L 2P3
+1 416 755 2291

BUFFALO

93 EAST AVENUE
NORTH TONAWANDA, NEW YORK
U.S.A.
14120-6594
+1 716 693 8813

BIRMINGHAM

HEYWOOD WHARF, MUCKLOW HILL
HALESOWEN, WEST MIDLANDS
UNITED KINGDOM
B62 8DJ
+44 (0) 8444 145 145

MANCHESTER

WOLVERTON STREET
MANCHESTER
UNITED KINGDOM
M11 2ET
+44 (0) 8444 145 145

BANGALORE

#59, FIRST FLOOR, 3RD MAIN
MARGOSA ROAD, MALLESWARAM
BANGALORE, INDIA
560 003
+91 (0) 80 4906 3555

SHANGHAI

NO. 1619 HU HANG ROAD, XI DU TOWNSHIP
FENG XIAN DISTRICT, SHANGHAI
P.R.C.
201401
+86 21 3756 6696

SÃO PAULO

RUA JOSÉ SEMIÃO RODRIGUES AGOSTINHO,
1370 GALPÃO 6
EMBU DAS ARTES
SAO PAULO, BRAZIL
+55 11 4781 5500

ARMSTRONG FLUID TECHNOLOGY
ESTABLISHED 1934

ARMSTRONGFLUIDTECHNOLOGY.COM

**MAKING
ENERGY
MAKE
SENSE™**

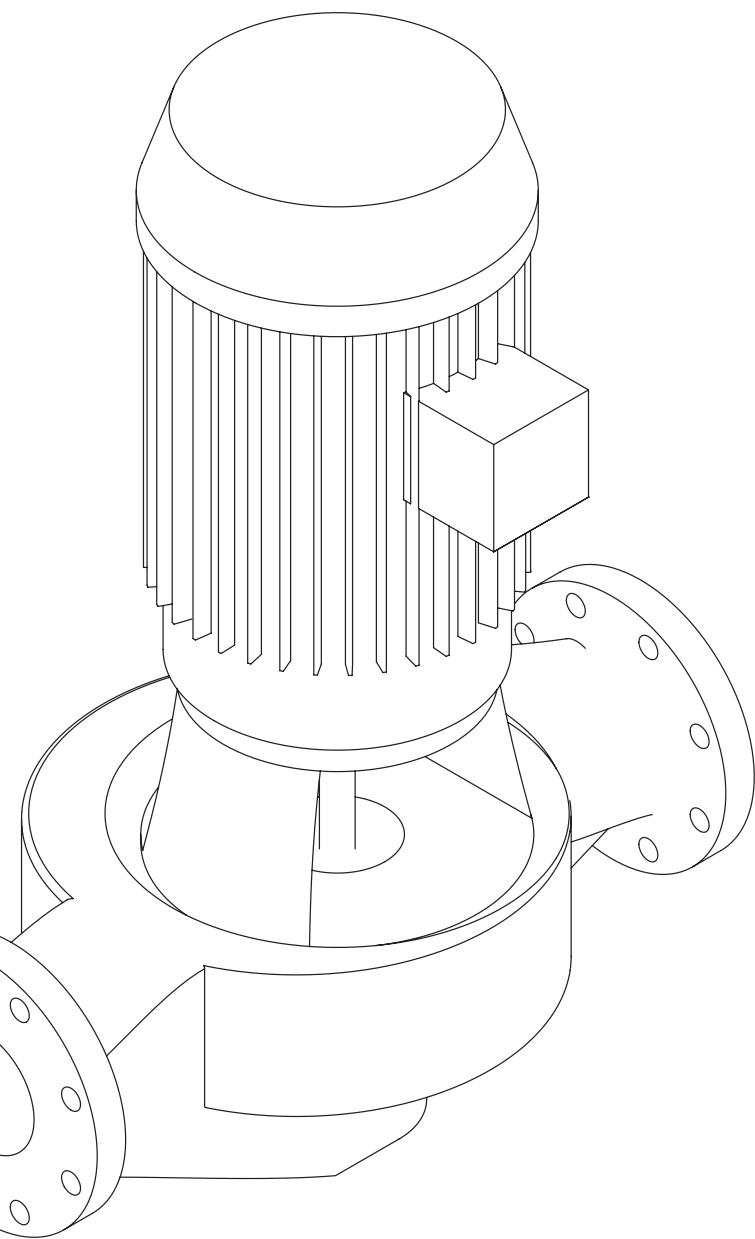

Series 4300 Vertical in-line

Equal suction & discharge 'M' designation

Parts list

TC motors only, groups 5 to 20

1 $\frac{1}{4}$ " impeller bore

1 $\frac{5}{8}$ " mechanical seal

File No: 6043.134
Date: NOVEMBER 20, 2015
Supersedes: 6043.134
Date: OCTOBER 7, 2015

4300 POWER FRAMES: ALL SPEEDS

PUMP SIZE	GROUP NUMBER	MOTOR FRAMES									
		143 145	182 184	FT215 213 215	254 256	284 286	324 326	FF300/FF350 364 365	404 405	444 445	447 449
1½×1×6	1	TC	—	—	—	—	—	—	—	—	—
	2	—	TC	—	—	—	—	—	—	—	—
2×2×6	1	TC	—	—	—	—	—	—	—	—	—
	2	—	TC	—	—	—	—	—	—	—	—
	3	—	—	TC	—	—	—	—	—	—	—
3×3×6	1	TC	—	—	—	—	—	—	—	—	—
	2	—	TC	—	—	—	—	—	—	—	—
	3	—	—	TC	—	—	—	—	—	—	—
4×4×6	1	TC	—	—	—	—	—	—	—	—	—
	2	—	TC	—	—	—	—	—	—	—	—
	3	—	—	TC	—	—	—	—	—	—	—
	4	—	—	—	TC	—	—	—	—	—	—
1½×1½×8	1	TC	—	—	—	—	—	—	—	—	—
	2	—	TC	—	—	—	—	—	—	—	—
	3	—	—	TC	—	—	—	—	—	—	—
2×2×8	1	TC	—	—	—	—	—	—	—	—	—
	2	—	TC	—	—	—	—	—	—	—	—
	3	—	—	TC	—	—	—	—	—	—	—
	4	—	—	—	TC	—	—	—	—	—	—
	5	—	—	—	—	TSC	—	—	—	—	—
3×3×8	1	TC	—	—	—	—	—	—	—	—	—
	2	—	TC	—	—	—	—	—	—	—	—
	3	—	—	TC	—	—	—	—	—	—	—
	4	—	—	—	TC	—	—	—	—	—	—
	5	—	—	—	—	TSC	—	—	—	—	—
	6	—	—	—	—	—	TSC	—	—	—	—
4×4×8	1	TC	—	—	—	—	—	—	—	—	—
	2	—	TC	—	—	—	—	—	—	—	—
	3	—	—	TC	—	—	—	—	—	—	—
	4	—	—	—	TC	—	—	—	—	—	—
	5	—	—	—	—	TSC	—	—	—	—	—
	6	—	—	—	—	—	TSC	TSC	—	—	—
	7	—	—	—	—	—	—	—	TSC	—	—
5×5×8	1	TC	—	—	—	—	—	—	—	—	—
	2	—	TC	—	—	—	—	—	—	—	—
	3	—	—	TC	—	—	—	—	—	—	—
	4	—	—	—	TC	—	—	—	—	—	—
	5	—	—	—	—	TSC	—	—	—	—	—
	6	—	—	—	—	—	TSC	—	—	—	—
6×6×8	2	—	TC	—	—	—	—	—	—	—	—
	3	—	—	TC	—	—	—	—	—	—	—
	4	—	—	—	TC	—	—	—	—	—	—
8×8×8	2	—	TC	—	—	—	—	—	—	—	—
	3	—	—	TC	—	—	—	—	—	—	—
	4	—	—	—	TC	—	—	—	—	—	—
2×2×10	1	TC	—	—	—	—	—	—	—	—	—
	2	—	TC	—	—	—	—	—	—	—	—
	3	—	—	TC	—	—	—	—	—	—	—
	4	—	—	—	TC	—	—	—	—	—	—
	5	—	—	—	—	TSC	—	—	—	—	—
	6	—	—	—	—	—	TSC	—	—	—	—

4300 POWER FRAMES: ALL SPEEDS (continued)

4300 GROUP NUMBER	5	6	7	8	9	10	11	12
SEAL SIZE AND PUMP SHAFT DIAMETER	1½	1½	1½	1 ⅝	1½	1½	1½	1½
IMPELLER BORE	1¼	1¼	1¼	1¼	1¼	1¼	1¼	1¼
COUPLING BORE	MOTOR SHAFT DIAMETER	1½	1⅞	2⅛	1⅞	2⅛	2⅜	1⅞
	PUMP SHAFT DIAMETER	1½	1½	1½	1½	1½	1½	1½
SHAFT GAP BETWEEN PUMP AND MOTOR	2¾	2⅞	2⅜	1⅜	1⅜	1⅜	2½	2

4300 GROUP NUMBER	13	14	15	16	17	18	19	20
SEAL SIZE AND PUMP SHAFT DIAMETER	1½	1½	1½	1½	1½	1½	1½	1½
IMPELLER BORE	1¼	1¼	1¼	1¼	1¼	1¼	1¼	1¼
COUPLING BORE	MOTOR SHAFT DIAMETER	1½	1⅞	2⅛	1⅞	2⅜	1⅞	2⅜
	PUMP SHAFT DIAMETER	1½	1½	1½	1½	1½	1½	1½
SHAFT GAP BETWEEN PUMP AND MOTOR	1⅜	1⅜	1⅜	2⅞	1⅜	2⅞	2⅜	1⅞

CROSS SECTION VIEW

Groups 5, 6, 7, 8, 9 & 10

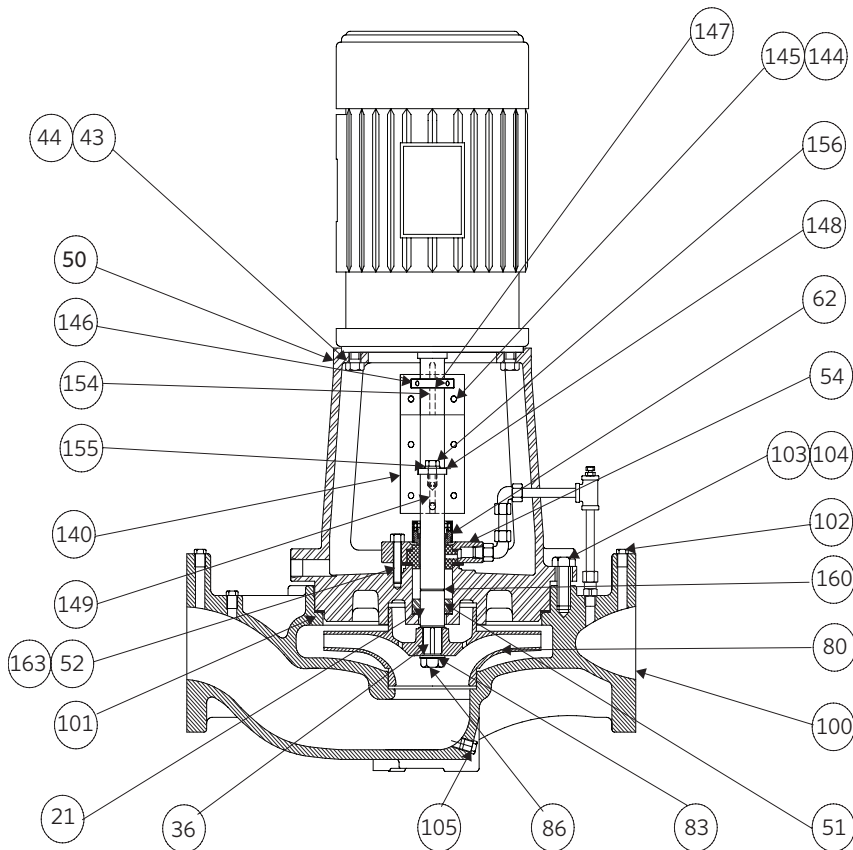

MECHANICAL SEAL

Exploded view

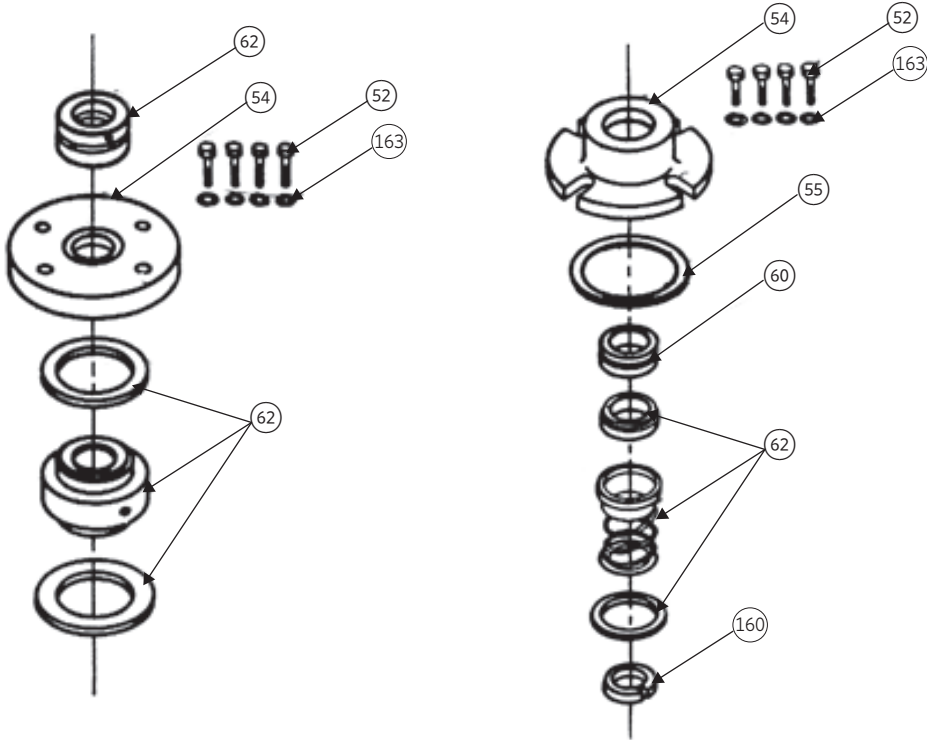

OUTSIDE MECHANICAL SEAL

INSIDE MECHANICAL SEAL

INDEX

ITEM	DESCRIPTION	PAGE
21	Shaft	24
36	Impeller key	24
43	Lockwasher	20
44	Motor capscrew	20
50	Stuffing box/adapter	16 to 18
51	Seal chamber bushing	24
52	Seal cover capscrew	24 & 25
54	Seal cover	24
55	Inside seal cover gasket	25
58	Male straight connector	25
59	Tubing	25
60	Inside seal seat	
62	Outside mechanical seal John crane STD.	24
62	Outside mechanical seal John crane T.C.	24
62	Outside mechanical seal Durametallc STD.	24
62	Outside mechanical seal Durametallc T.C.	24
62	Inside mechanical seal head B.F. & A.I. construction	25
63	¼" NPT tee	25
68	Air vent	25
80	Impeller	10 & 11
83	Impeller washer	24
86	Impeller capscrew	24
90	Case wear ring	11 & 12
100	Casing	8&9

ITEM	DESCRIPTION	PAGE
101	Casing gasket	13
102	Gauge plug	24
103	Casing capscrew washer	14
104	Casing capscrew	14
105	Casing drain plug	15
140	Coupler	23
144	Coupler capscrew	24
145	Lockwasher	24
146	Coupler collar set screw	22
147	Motor shaft coupler collar	22
148	Pump shaft coupler collar	24
149	Coupler square key (pump)	24
150	Coupling guard (not shown)	19
151	Coupler guard bolt (not shown)	19
152	Nut (not shown)	19
153	Washer (not shown)	19
154	Coup. Square key (motor)	21
155	Capscrew lockwasher	24
156	Shaft capscrew	24
160	Inside seal retaining ring	25
163	Seal cover capscrew washer	24 & 25
194	Male 90° angle connection	25
195	Adapter ring (not shown)	

8

ITEM 100 CASING**

PUMP SIZE	PRESSURE RATING (LB)	CONSTRUCTION	PART NUMBER
2×2×8	125#	Cast iron	427047-011
	250#	Ductile iron	427048-031
	125#	All bronze	427047-041
3×3×8	125#	Cast iron	427051-011
	250#	Ductile iron	427052-031
	125#	All bronze	427051-041
4×4×8	125#	Cast iron	427053-011
	250#	Ductile iron	427054-031
	125#	All bronze	427053-041
5×5×8	125#	Cast iron	427024-011
	250#	Ductile iron	427025-031
	125#	All bronze	427024-041
2×2×10	125#	Cast iron	427059-011
	250#	Ductile iron	427060-031
	125#	All bronze	427059-041
3×3×10	125#	Cast iron	427061-011
	250#	Ductile iron	427062-031
	125#	All bronze	427061-041
4×4×10	125#	Cast iron	427063-011
	250#	Ductile iron	427064-031
	125#	All bronze	427063-041
6×6×10	125#	Cast iron	427065-011
	250#	Ductile iron	427066-031
	125#	All bronze	427065-041
8×8×10	125#	Cast iron	427067-011
	250#	Ductile iron	427068-031
	125#	All bronze	427067-041
4×4×11½	125#	Cast iron	426119-011
	250#	Ductile iron	426120-031
	125#	All bronze	426119-041
5×5×11½	125#	Cast iron	426123-011
	250#	Ductile iron	426124-031
	125#	All bronze	426123-041
6×6×11½	125#	Cast iron	426127-011
	250#	Ductile iron	426128-031
	125#	All bronze	426127-041

ITEM 100 CASING (continued)**

PUMP SIZE	PRESSURE RATING (LB)	CONSTRUCTION	PART NUMBER
8×8×11½	125#	Cast iron	426131-011
	250#	Ductile iron	426132-031
	125#	All bronze	426131-041
3×3×13	125#	Cast iron	427071- 011
	250#	Ductile iron	427072- 031
	125#	Stainless steel	427071- 071
	125#	All bronze	427071- 041
4×4×13	125#	Cast iron	427073- 011
	250#	Ductile iron	427074- 031
	125#	Stainless steel	427073- 071
	125#	All bronze	427074- 041
5×5×13	125#	Cast iron	427193-011
	250#	Ductile iron	427194-031
5×5×13H	125#	Cast iron	427193-017
	250#	Ductile iron	427194-037
6×6×13†	125#	Cast iron	427183-011
	250#	Ductile iron	427184-031
6×6×13H	125#	Cast iron	427183-017
	250#	Ductile iron	427184-037
8×8×13*** (PRE AUGUST 2015)	125#	Cast iron	427077-011
	250#	Ductile iron	427078-031
	125#	Stainless steel	427207-071
	125#	All bronze	427207-041
8×8×13*** (POST AUGUST 2015)	125#	Cast iron	427207-011
	250#	Ductile iron	427208-031
10×10×13	125#	Cast iron	427328-011
	250#	Ductile iron	427329-031
	125#	Stainless steel	427328-071
	125#	All bronze	427328-041

NOTES:

- ** Casing part numbers are for casing only, casing wear ring is sold separately. If new casing is required, it must be ordered c/w wear ring
- † For 6x6x13 units pre-June 2011, casing & impeller must be replaced together. Contact Armstrong for details.
- *** For 8x8x13 pumps, there was a revision to the the casing and impeller done in August 2015. These two parts are not interchangeable between the old and new pumps. Please consult your Armstrong representative if you need extra assistance.

ITEM 80 IMPELLER 1¼" BORE**

PUMP SIZE	MATERIAL	IMPELLER BORE	MAXIMUM DIAMETER	PART NUMBER
2×2×8	Bronze	1¼"	8"	427122-041
	Cast iron	1¼"	8"	427122-011
3×3×8	Bronze	1¼"	8"	427130-041
	Cast iron	1¼"	8"	427130-011
4×4×8	Bronze	1¼"	8"	427138-041
	Cast iron	1¼"	8"	427138-011
5×5×8	Bronze	1¼"	8"	427132-041
	Cast iron	1¼"	8"	427138-011
2×2×10	Bronze	1¼"	10"	427152-041
	Cast iron	1¼"	10"	427152-011
3×3×10	Bronze	1¼"	10"	427164-041
	Cast iron	1¼"	10"	427164-011
4×4×10	Bronze	1¼"	10"	427150-041
	Cast iron	1¼"	10"	427150-011
6×6×10	Bronze	1¼"	10"	427154-041
	Cast iron	1¼"	10"	427154-011
8×8×10	Bronze	1¼"	10"	427157-041
	Cast iron	1¼"	10"	427157-011
6×6×10	Bronze	1¼"	10"	427154-041
	Cast iron	1¼"	10"	427154-011
8×8×10	Bronze	1¼"	10"	427157-041
	Cast iron	1¼"	10"	427157-011
4×4×11½	Bronze	1¼"	11½"	426282-041
	Cast iron	1¼"	11½"	426282-011
5×5×11½	Bronze	1¼"	11½"	426284-041
	Cast iron	1¼"	11½"	426284-011
6×6×11½	Bronze	1¼"	11½"	426288-041
	Cast iron	1¼"	11½"	426288-011
8×8×11½	Bronze	1¼"	11½"	426289-041
	Cast iron	1¼"	11½"	426289-011
3×3×13	Bronze	1¼"	13"	427165-041
	Cast iron	1¼"	13"	427165-011
4×4×13	Bronze	1¼"	13"	427169-041
	Cast iron	1¼"	13"	427169-011

ITEM 80 IMPELLER 1¼" BORE (continued)**

PUMP SIZE	MATERIAL	IMPELLER BORE	MAXIMUM DIAMETER	PART NUMBER
5×5×13	Bronze	1¼"	13"	427186-041
	Cast iron	1¼"	13"	427186-011
5×5×13H	Bronze	1¼"	13"	427182-041
	Cast iron	1¼"	13"	427182-011
6×6×13†	Bronze	1¼"	13"	427182-041
6×6×13H	Bronze	1¼"	13"	427177-041
8×8×13*** (PRE AUGUST 2015)	Cast iron	1¼"	13"	427205-041
	Ductile iron	1¼"	13"	427205-011
8×8×13*** (POST AUGUST 2015)	Cast iron	1¼"	13"	427177-041
	Ductile iron	1¼"	13"	427177-011
	Stainless steel	1¼"	13"	427177-071
10×10×13	Bronze	1¼"	13"	427332-041
	Cast iron	1¼"	13"	427332-011

NOTES:

** Impeller part numbers are for full or maximum diameter impellers. Always specify pump serial number and where possible, measure and advise the diameter of the Impeller being replaced on these Pumps.

† For 6×6×13 units pre-June 2011, casing & impeller must be replaced together. Contact Armstrong for details.

*** For 8×8×13 pumps, there was a revision to the the casing and impeller done in August 2015. These two parts are not interchangeable between the old and new pumps. Please consult your Armstrong representative if you need extra assistance.

ITEM 90 CASE WEAR RING

PUMP SIZE	CONSTRUCTION	MATERIAL	PART NUMBER
2×2×8	All bronze, Bronze fitted	SAE 660 BRONZE	426413-404
	All iron, Ductile iron	CLASS 30 CAST IRON	426413-104
3×3×8	All bronze, Bronze fitted	SAE 660 BRONZE	426413-407
	All iron, Ductile iron	CLASS 30 CAST IRON	426413-107
4×4×8	All bronze, Bronze fitted	SAE 660 BRONZE	426413-410
	All iron, Ductile iron	CLASS 30 CAST IRON	426413-110
5×5×8	All bronze, Bronze fitted	SAE 660 BRONZE	426413-413
	All iron, Ductile iron	CLASS 30 CAST IRON	426413-113
2×2×10	All bronze, Bronze fitted	SAE 660 BRONZE	426413-404
	All iron, Ductile iron	CLASS 30 CAST IRON	426413-104
3×3×10	All bronze, Bronze fitted	SAE 660 BRONZE	426413-404
	All iron, Ductile iron	CLASS 30 CAST IRON	426413-104

ITEM 90 CASE WEAR RING (continued)

PUMP SIZE	CONSTRUCTION	MATERIAL	PART NUMBER
4×4×10	All bronze, Bronze fitted	SAE 660 BRONZE	426413-408
	All iron, Ductile iron	CLASS 30 CAST IRON	426413-108
6×6×10	All bronze, Bronze fitted	SAE 660 BRONZE	426413-412
	All iron, Ductile iron	CLASS 30 CAST IRON	426413-112
8×8×10	All bronze, Bronze fitted	SAE 660 BRONZE	426413-414
	All iron, Ductile iron	CLASS 30 CAST IRON	426413-114
4×4×11½	All bronze, Bronze fitted	SAE 660 BRONZE	426412-405
	All iron, Ductile iron	CLASS 30 CAST IRON	426412-105
5×5×11½	All bronze, Bronze fitted	SAE 660 BRONZE	426412-411
	All iron, Ductile iron	CLASS 30 CAST IRON	426412-111
6×6×11½	All bronze, Bronze fitted	SAE 660 BRONZE	426412-420
	All iron, Ductile iron	CLASS 30 CAST IRON	426412-120
8×8×11½	All bronze, Bronze fitted	SAE 660 BRONZE	426412-421
	All iron, Ductile iron	CLASS 30 CAST IRON	426412-121
3×3×13	All bronze, Bronze fitted	SAE 660 BRONZE	426413-409
	Stainless steel	STAINLESS STEEL	426413-709
	All iron, Ductile iron	CLASS 30 CAST IRON	426413-109
4×4×13	All bronze, Bronze fitted	SAE 660 BRONZE	426413-412
	Stainless steel	STAINLESS STEEL	426413-712
	All iron, Ductile iron	CLASS 30 CAST IRON	426413-112
5 × 5 × 13	All bronze, Bronze fitted	SAE 660 BRONZE	426412-411
	Stainless steel 316	STAINLESS STEEL	426412-711
5 × 5 × 13H	All bronze, Bronze fitted	SAE 660 BRONZE	NA
	Stainless steel 316	STAINLESS STEEL	NA
6×6×13	Bronze fitted	SAE 660 BRONZE	426412-420
6×6×13H	—	—	—
8×8×13	All bronze, Bronze fitted	SAE 660 BRONZE	426413-415
	Stainless steel	STAINLESS STEEL	426413-715
	All iron, Ductile iron	CLASS 30 CAST IRON	426413-115
10×10×13	All bronze, Bronze fitted	SAE 660 BRONZE	426413-417
	Stainless steel	STAINLESS STEEL	426413-717
	All iron, Ductile iron	CLASS 30 CAST IRON	426413-117

ITEM 101 CASING GASKET

PUMP SIZE	CONSTRUCTION	PART NUMBER
2×2×8	ALL	426401-003
3×3×8		
4×4×8		
5×5×8		
2×2×10	ALL	426401-004
3×3×10		
4×4×10		
6×6×10		
8×8×10		
4×4×11½	ALL	426401-006
5×5×11½		
6×6×11½		
8×8×11½		
3×3×13	ALL	426401-005
4×4×13		
5×5×13		
5×5×13H		
6×6×13		
6×6×13H		
8×8×13		
10×10×13		

ITEM 104 CASING CAPSCREW & ITEM 103 WASHER

PUMP SIZE	NUMBER REQUIRED	FRAMES 182 TO 256-10 CAPSCREW	NUMBER REQUIRED	FRAMES 182 TO 256-10 WASHER	NUMBER REQUIRED	FRAMES 284 TO 405-16 CAPSCREW	NUMBER REQUIRED	FRAMES 284 TO 405-16 WASHER
2×2×8	—	—	—	—	8	⅝"-11NC 1½" LG. 911129-112	8	⅝" FLAT 927121-100
3×3×8								
4×4×8								
5×5×8								
2×2×10	—	—	—	—	12	⅝"-11NC 1½" LG. 911129-112	12	⅝" FLAT 927121-100
3×3×10								
6×6×10								
8×8×10								
4×4×10					12	⅝"-11NC 1¾" LG. 911129-114	12	⅝" LOCK- WASHER 927215-100
4×4×11½	—	—	—	—	16	½"-13NC 1½" LG. 911125-112	16	½" FLAT 927114-100
5×5×11½								
6×6×11½								
8×8×11½								
3×3×13	16	⅝"-11NC 2" LG. 911129-116	16	⅝" FLAT 927121-100	16	⅝"-11NC 2" LG. 911129-116	16	⅝" FLAT 927121-100
4×4×13								
5×5×13								
5×5×13H								
6×6×13								
6×6×13H								
8×8×13								
10×10×13	—	—	—	—				

ITEM 105 CASING DRAIN PLUG

PUMP SIZE	MATERIAL	NUMBER REQUIRED	SIZE	PART NUMBER				
2×2×8	CAD PLATED	1	¼"NPT	937105-201				
3×3×8								
4×4×8								
5×5×8								
2×2×10								
3×3×10								
4×4×10								
8×8×10								
4×4×11½								
5×5×11½								
3×3×13								
4×4×13								
5×5×8					CAD PLATED	1	½"NPT	937105-203
6×6×10								
6×6×11½								
8×8×11½								
5×5×13								
5×5×13H								
6×6×13								
6×6×13H								
8×8×13								
10×10×13								

ITEM 50 ADAPTER

Bronze fitted and All iron construction

PUMP SIZE	MOTOR FRAME SIZE	MATERIAL	PART NUMBER
2×2×8 3×3×8 4×4×8 5×5×8 6×6×8	284 - 286TSC	Cast iron	427707-011
	324 - 326TSC		427710-015
2×2×10 3×3×10 6×6×10 8×8×10	284 - 286TSC	Cast iron	427708-011
	324 - 326TSC		427711-011
4×4×10	284 - 286TSC	Cast iron	427708-015
	324 - 326TSC		427711-015
4×4×11½ 5×5×11½ 6×6×11½ 8×8×11½	284 - 286TC	Cast iron	427709-011
	324 - 326TC		427712-011
3×3×13	182 - 256TC	Cast iron	427840-011
	284 - 286TC		427841-011
	324 - 405TSC		427842-011
	444 - 445TSC		427856-011
4×4×13	184 - 256TC	Cast iron	427840-011
	284 - 286TC		427841-011
	324TSC		427842-011
5×5×13 5×5×13H	215 - 256TC	Cast iron	427840-011
	284 - 286TC		427841-011
	324 - 365TC		427842-011
6×6×13 6×6×13H	215 - 256TC	Cast iron	427840-011
	284 - 286TC		427841-011
	324 - 365TC		427842-011
8×8×13	215 - 256TC	Cast iron	427840-011
	284 - 286TC		427841-011
	324 - 365TC		427842-011
10×10×13	284 - 286TC	Cast iron	427841-011
	324 - 326TC		427842-011

ITEM 50 PUMPS STUFFING BOX

13" Bronze fitted and All iron construction

PUMP SIZE	MOTOR FRAME SIZE	MATERIAL	PART NUMBER
13" PUMPS	ALL	Cast iron	427884-011

ITEM 150

13" pumps motor adapter ring all constructions

PUMP SIZE	MOTOR FRAME SIZE	MATERIAL	PART NUMBER
ALL	284 - 286TC	Steel	427850-000
ALL	364 - 365TC	Steel	427730-000

ITEM 50 ADAPTER

Ductile iron construction

PUMP SIZE	MOTOR FRAME SIZE	MATERIAL	PART NUMBER	
2×2×8 3×3×8 4×4×8	284 - 286TSC	Cast iron	427707-011	
5×5×8 6×6×8	324 - 326TSC		427710-015	
2×2×10 3×3×10 6×6×10	284 - 286TSC		Cast iron	427708-011
8×8×10	324 - 326TSC			427711-011
4×4×10	284 - 286TSC	Cast iron	427708-015	
	324 - 326TSC		427711-015	
4×4×11½ 5×5×11½ 6×6×11½	284 - 286TC	Cast iron	427709-011	
8×8×11½	324 - 326TC		427712-011	
3×3×13	182 - 256TC	Cast iron	427840-011	
	284 - 286TC		427841-011	
	324 - 405TSC		427842-011	
	444 - 445TSC		427856-011	
4×4×13	184 - 256TC	Cast iron	427840-011	
	284 - 286TC		427841-011	
	324TSC		427842-011	
5×5×13 5×5×13H	215 - 256TC	Cast iron	427840-011	
	284 - 286TC		427841-011	
	324 - 365TC		427842-011	
6×6×13 6×6×13H	215 - 256TC	Cast iron	427840-011	
	284 - 286TC		427841-011	
	324 - 365TC		427842-011	
8×8×13	215 - 256TC	Cast iron	427840-011	
	284 - 286TC		427841-011	
	324 - 365TC		427842-011	
10×10×13	284 - 286TC	Cast iron	427841-011	
	324 - 326TC		427842-011	

ITEM 50 PUMPS STUFFING BOX

13" Bronze fitted and All iron construction

PUMP SIZE	MOTOR FRAME SIZE	MATERIAL	PART NUMBER
13" PUMPS	ALL	Cast iron	427884-011

ITEM 50 ADAPTER

All bronze construction

PUMP SIZE	MOTOR FRAME SIZE	MATERIAL	PART NUMBER
2×2×8 3×3×8 4×4×8 5×5×8 6×6×8	284 - 286TSC 324 - 326TSC	Bronze	427707-041 427710-045
2×2×10 3×3×10 6×6×10 8×8×10	284 - 286TSC 324 - 326TSC	Cast bronze	427708-041 427711-041
4×4×10	284 - 286TSC 324 - 326TSC	Cast bronze	427708-045 427711-045
4×4×11½ 5×5×11½ 6×6×11½ 8×8×11½	284 - 286TC 324 - 326TC	Cast bronze	427709-041 427712-041
3×3×13	182 - 256TC	Cast bronze	427840-041
	284 - 286TC		427841-041
	324 - 405TSC		427842-041
	444 - 445TSC		427856-041
4×4×13	184 - 256TC	Cast bronze	427840-041
	284 - 286TC		427841-041
	324TSC		427842-041
5×5×13 5×5×13H	215 - 256TC	Cast bronze	427840-041
	284 - 286TC		427841-041
	324 - 365TC		427842-041
6×6×13 6×6×13H	215 - 256TC	Cast bronze	427840-041
	284 - 286TC		427841-041
	324 - 365TC		427842-041
8×8×13	215 - 256TC	Cast bronze	427840-041
	284 - 286TC		427841-041
	324 - 365TC		427842-041
10×10×13	284 - 286TC	Cast bronze	427841-041
	324 - 326TC		427842-041

ITEM 50 PUMPS STUFFING BOX

13" Bronze fitted and All iron construction

PUMP SIZE	MOTOR FRAME SIZE	MATERIAL	PART NUMBER
13" PUMPS	ALL	Cast bronze	427884-041

ITEM 150

13" pumps motor adapter ring all constructions

PUMP SIZE	MOTOR FRAME SIZE	MATERIAL	PART NUMBER
ALL	284 - 286TC	Steel	427850-000
ALL	364 - 365TC	Steel	427730-000

ITEM 150 COUPLER GUARD

PUMP SIZE	MOTOR FRAME SIZE	PART NUMBER
2×2×8	284 - 286TSC	427761-007
3×3×8		
4×4×8		
5×5×8	324 - 326TSC	
6×6×8		
2×2×10	284 - 286TSC	427761-008
3×3×10	324 - 326TSC	427761-007
4×4×10		
6×6×10		
8×8×10		
4×4×11½	284 - 286TC	427761-008
5×5×11½	324 - 326TC	427761-007
6×6×11½		
8×8×11½		
3×3×13	182TC- 286TC	427859-000
4×4×13		
5×5×13		
5×5×13H		
6×6×13	324 - 445TC & TSC	427858-000
6×6×13H		
8×8×13		
10×10×13		

COUPLER GUARD FASTENERS

ITEM NUMBER	DESCRIPTION	NUMBER REQUIRED	SIZE	PART NUMBER
151	Bolt - RD. HD.	2	#8-32×1½"	916262-100
152	Nut	2	#8-32	913162-100
153	Washer	2	#8-32	927105-100

ITEM 44 MOTOR CAPSCREW & ITEM 43 LOCKWASHER

PUMP SIZE	MOTOR FRAME SIZE	ITEM DESCRIPTION	PART NUMBER
1½×1½×8	284 - 286TSC	CAPSCREW	911125-110
2×2×8		LOCKWASHER	927213-100
3×3×8	324 - 326TSC	CAPSCREW	911129-112
4×4×8		LOCKWASHER	927215-100
5×5×8		CAPSCREW	911125-110
6×6×8		LOCKWASHER	927213-100
2×2×10	284 - 286TSC	CAPSCREW	911129-112
3×3×10		LOCKWASHER	927215-100
4×4×10	324 - 326TSC	CAPSCREW	911125-110
6×6×10		LOCKWASHER	927213-100
8×8×10		CAPSCREW	911129-112
4×4×11½	284 - 286TC	LOCKWASHER	927215-100
5×5×11½		CAPSCREW	911125-110
6×6×11½	324 - 326TC	LOCKWASHER	927213-100
6×6×11½		CAPSCREW	911129-112
8×8×11½		LOCKWASHER	927215-100
3×3×13	184 - 286TC	CAPSCREW	911125-114
4×4×13		LOCKWASHER	927213-100
5×5×13		CAPSCREW	911129-112
5×5×13H	324 - 446TC	LOCKWASHER	927215-100
6×6×13		CAPSCREW	911125-110
6×6×13H		LOCKWASHER	927213-100
8×8×13		CAPSCREW	911129-112
10×10×13		LOCKWASHER	927215-100

ITEM 154 MOTOR KEY

PUMP SIZE	MOTOR FRAME SIZE	PART NUMBER	PUMP SIZE	MOTOR FRAME SIZE	PART NUMBER
1½×1½×8	284 - 286TSC	428163-714	3×3×13	284 - 326TC	428164-116
2×2×8			4×4×13		
3×3×8			5×5×13		
4×4×8			5×5×13H		
5×5×8	6×6×13				
6×6×8	6×6×13H				
2×2×10	8×8×13				
3×3×10	10×10×13				
4×4×10	4×4×13	324 - 325TSC			
6×6×10	5×5×13				
8×8×10	5×5×13H				
4×4×11½	6×6×13				
5×5×11½	6×6×13H				
6×6×11½	8×8×13				
8×8×11½	10×10×13				
3×3×13	364 - 365TSC		428164-112		
4×4×13	5×5×13				
5×5×13	5×5×13H				
5×5×13H	6×6×13				
6×6×13	6×6×13H				
6×6×13H	8×8×13				
8×8×13	10×10×13				
3×3×13	364 - 365TC	428164-117			
4×4×13	5×5×13				
5×5×13	5×5×13H				
5×5×13H	6×6×13				
6×6×13	6×6×13H	428167-103			
6×6×13H	3×3×13				
8×8×13	404 - 405TC				
3×3×13	182 - 215TC	428162-112	3×3×13	254 - 256TC	428163-714
4×4×13			4×4×13		
5×5×13			5×5×13		
5×5×13H			5×5×13H		
6×6×13			6×6×13		
6×6×13H			6×6×13H		
8×8×13			8×8×13		
3×3×13					

ITEM 147 MOTOR COUPLER COLLAR

PUMP SIZE	MOTOR FRAME SIZE	PART NUMBER
1½×1½×8	284 - 286TSC	427751-000
2×2×8		
3×3×8		
4×4×8		
5×5×8	324 - 326TSC	427752-000
6×6×8		
2×2×10	284 - 286TSC	427751-000
3×3×10		
4×4×10		
6×6×10	324 - 326TSC	427752-000
8×8×10		
4×4×11½	284 - 286TC	427752-000
5×5×11½		
6×6×11½	324 - 326TC	427753-000
8×8×11½		
3×3×13	182 - 184TC	427749-000
4×4×13		
3×3×13	213 - 215TC	427750-000
4×4×13		
5×5×13		
5×5×13H		
6×6×13		
6×6×13H		
8×8×13		
8×8×13		
3×3×13	254 - 256TC	427751-000
4×4×13		
5×5×13		
5×5×13H		
6×6×13		
6×6×13H		
8×8×13		

PUMP SIZE	MOTOR FRAME SIZE	PART NUMBER
3×3×13	284 - 286TC	427752-000
4×4×13		
5×5×13	324 - 326TSC	
5×5×13H		
6×6×13	364 - 365TSC	
6×6×13H		
8×8×13		
10×10×13		
3×3×13	324 - 325TSC	427753-000
4×4×13		
5×5×13		
5×5×13H		
6×6×13		
6×6×13H	404 - 405TSC	
8×8×13		
10×10×13		
3×3×13	364 - 365TC	427754-000
5×5×13		
5×5×13H		
6×6×13		
6×6×13H	445 - 446TSC	
8×8×13		
3×3×13	404 - 405TC	427889-000

ITEM 146 MOTOR COUPLER COLLAR SET SCREW

PUMP SIZE	MOTOR FRAME SIZE	PART NUMBER
All	TCS & TC 182 - 445	916519-106

ITEM 140 COUPLER

PUMP SIZE	MOTOR FRAME SIZE	PART NUMBER	SHAFT GAP
1½×1½×8	284 - 286TSC	427735-000	—
2×2×8			
3×3×8			
4×4×8			
5×5×8			
6×6×8	324 - 326TSC	427737-000	
2×2×10	284 - 286TSC	427735-000	—
3×3×10			
4×4×10			
6×6×10			
8×8×10	324 - 326TSC	427737-000	
4×4×11½	284 - 286TC	427736-000	—
5×5×11½			
6×6×11½			
8×8×11½	324 - 326TC	427738-000	
3×3×13	182 - 184TC	427864-000	2.505
4×4×13			
3×3×13	213 - 215TC	427865-000	2.005
4×4×13			
5×5×13			
5×5×13H			
6×6×13			
6×6×13H			
8×8×13			

PUMP SIZE	MOTOR FRAME SIZE	PART NUMBER	SHAFT GAP
3×3×13	254 - 256TC	427866-000	1.375
4×4×13			
5×5×13			
5×5×13H			
6×6×13			
6×6×13H			
8×8×13			
3×3×13	284 - 286TC	427736-000	1.375
4×4×13			
5×5×13			
5×5×13H			
6×6×13			
6×6×13H			
8×8×13	324 - 326TSC	427737-000	2.875
10×10×13			
3×3×13	364 - 365TSC		
4×4×13	324 - 326TC	427738-000	1.375
5×5×13			
5×5×13H			
6×6×13			
6×6×13H			
8×8×13			
10×10×13	364 - 365TC	427739-000	1.375
5×5×13			
5×5×13H			
6×6×13			
6×6×13H	404 - 405TSC	427740-000	2.375
8×8×13			
3×3×13	445 - 446TSC	427839-000	1.375

COMMON PARTS

All constructions

ITEM NUMBER	DESCRIPTION	PART NUMBER
21	1½" pump shaft	427714-000
36	Impeller key	428161-714
51	Seal chamber bushing	425520-001
83	Impeller washer	425742-003
86	Impeller capscrew	911900-119
102	Gauge plug (4 required) ¼" NPT. CAD plated	937105-201
144	Coupler capscrew (6 required) Frames 182TC to 365TC and 324-446TSC	911821-116
145	Lockwasher (for item 144)	927211-100
148	Shaft coupler collar	427757-000
149	Cplr. Key (pump shaft)	428163-712
155	Capscrew lockwasher	927213-400
156	Coupler collar capscrew	911125-408

PARTS FOR 1½" OUTSIDE SEAL

ITEM NUMBER	DESCRIPTION	CONSTRUCTION	PART NUMBER
62	Mechanical seal		
	Armstrong seal	All	975002-334
	Durametallic STD.	All	975002-033
	Durametallic T.C.	All	975002-031
	John crane STD.	All	975000-956
	John crane T.C.	All	975000-966
52	Capscrew - 4 required ½"-13NCx1¾" S/S	All	911125-414
163	Washer - 4 required ½" FLAT S/S	All	427118-100
54	Seal cover	Bronze fitted, All bronze, Ductile bronze fitted	426485-002
		All iron, Ductile iron	426485-001

PARTS FOR 1½" INSIDE MECHANICAL SEAL ARRANGEMENT

ITEM NUMBER	DESCRIPTION	CONSTRUCTION	PART NUMBER
62	Mechanical seal	All	810150-135
52	Capscrew - 4 required ½"-13NCx1¾" S/S	All	911125-414
163	Washer - 4 required ½" FLAT S/S	All	427118-100
54	Seal cover	All	426465-011
55	Gasket	All	426467-002
160	Retaining ring	All	923104-442

STANDARD MECHANICAL SEAL FLUSH LINE PARTS

ITEM NUMBER	DESCRIPTION	NUMBER REQUIRED	CONSTRUCTION	PART NUMBER
58	MALE STRAIGHT CONNECTION ¾" TUBE x ¼" NPT	1	Bronze fitted, All bronze, Ductile bronze fitted	939001-114
			All iron, Ductile iron	939001-314
59	TUBING 20" REQUIRED ¾" OD x .035 WALL	20"	Bronze fitted, All bronze, Ductile bronze fitted	997531-004
			All iron, Ductile iron	997153-004
63	TEE ¼" NPT	1	Bronze fitted, All bronze, Ductile bronze fitted	935101-001
			All iron, Ductile iron	931101-101
64	BUSHING ¼" MNPT x ⅛" FNPT	1	Bronze fitted, All bronze, Ductile bronze fitted	935123-050
			All iron, Ductile iron	931123-150
67	NIPPLE ¼" NPT x 2½" NPT	1	Bronze fitted, All bronze, Ductile bronze fitted	938103-001
			All iron, Ductile iron	938003-101
68	AIR VENT	1	Bronze fitted, All bronze, Ductile bronze fitted	939018-101
			All iron, Ductile iron	218644-000
194	MALE 90° CONNECTION ¾" TUBE x ¼" NPT	1	Bronze fitted, All bronze, Ductile bronze fitted	939003-109
			All iron, Ductile iron	939003-309

FOR OTHER FLUSH LINE OPTIONS, SEE FLUSH LINE OPTIONS PARTS LIST

TORONTO

23 BERTRAND AVENUE
TORONTO, ONTARIO
CANADA
M1L 2P3
+1 416 755 2291

BUFFALO

93 EAST AVENUE
NORTH TONAWANDA, NEW YORK
U.S.A.
14120-6594
+1 716 693 8813

BIRMINGHAM

HEYWOOD WHARF, MUCKLOW HILL
HALESOWEN, WEST MIDLANDS
UNITED KINGDOM
B62 8DJ
+44 (0) 8444 145 145

MANCHESTER

WOLVERTON STREET
MANCHESTER
UNITED KINGDOM
M11 2ET
+44 (0) 8444 145 145

BANGALORE

#59, FIRST FLOOR, 3RD MAIN
MARGOSA ROAD, MALLESWARAM
BANGALORE, INDIA
560 003
+91 (0) 80 4906 3555

SHANGHAI

NO. 1619 HU HANG ROAD, XI DU TOWNSHIP
FENG XIAN DISTRICT, SHANGHAI
P.R.C.
201401
+86 21 3756 6696

SÃO PAULO

RUA JOSÉ SEMIÃO RODRIGUES AGOSTINHO,
1370 GALPÃO 6
EMBU DAS ARTES
SAO PAULO, BRAZIL
+55 11 4781 5500

ARMSTRONG FLUID TECHNOLOGY
ESTABLISHED 1934

ARMSTRONGFLUIDTECHNOLOGY.COM

MAKING
ENERGY
MAKE
SENSE™

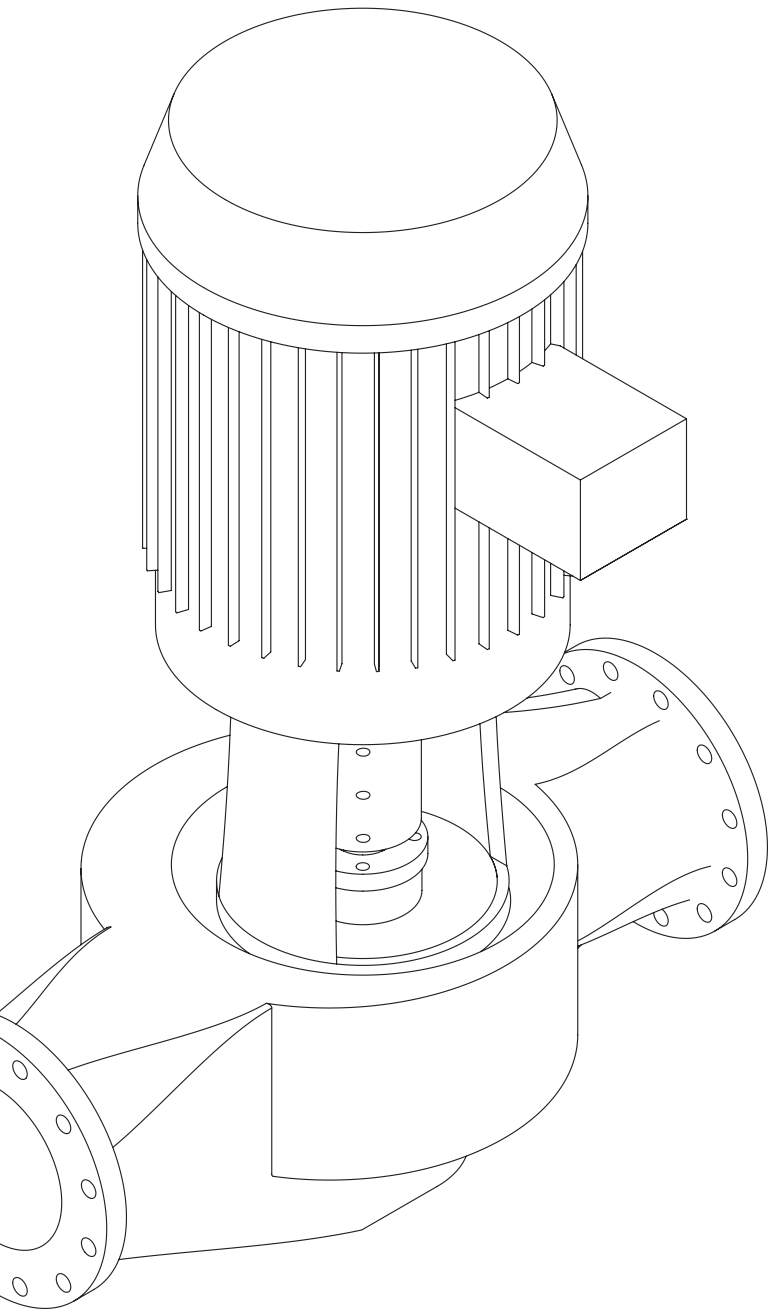

Series 4300 Vertical in-line

Equal suction & discharge 'S' designation

Parts list

TC motors only, groups 1 to 4

$\frac{7}{8}$ " impeller bore

$1\frac{1}{8}$ " mechanical seal or
packing gland

File No: 6043.132

Date: DECEMBER 04, 2015

Supersedes: 6043.132

Date: OCTOBER 15, 2013

4300 POWER FRAMES: ALL SPEEDS

PUMP SIZE	GROUP NUMBER	MOTOR FRAME									
		143 145	182 184	FT215 213 215	254 256	284 286	324 326	FF300/FF350 364 365	404 405	444 445	447 449
1 1/2 x 1 x 6	1	TC	—	—	—	—	—	—	—	—	—
	2	—	TC	—	—	—	—	—	—	—	—
2 x 2 x 6	1	TC	—	—	—	—	—	—	—	—	—
	2	—	TC	—	—	—	—	—	—	—	—
	3	—	—	TC	—	—	—	—	—	—	—
3 x 3 x 6	1	TC	—	—	—	—	—	—	—	—	—
	2	—	TC	—	—	—	—	—	—	—	—
	3	—	—	TC	—	—	—	—	—	—	—
	4	—	—	—	TC	—	—	—	—	—	—
4 x 4 x 6	1	TC	—	—	—	—	—	—	—	—	—
	2	—	TC	—	—	—	—	—	—	—	—
	3	—	—	TC	—	—	—	—	—	—	—
	4	—	—	—	TC	—	—	—	—	—	—
1 1/2 x 1 1/2 x 8	1	TC	—	—	—	—	—	—	—	—	—
	2	—	TC	—	—	—	—	—	—	—	—
	3	—	—	TC	—	—	—	—	—	—	—
2 x 2 x 8	1	TC	—	—	—	—	—	—	—	—	—
	2	—	TC	—	—	—	—	—	—	—	—
	3	—	—	TC	—	—	—	—	—	—	—
	4	—	—	—	TC	—	—	—	—	—	—
	5	—	—	—	—	—	—	—	—	—	—
3 x 3 x 8	1	TC	—	—	—	—	—	—	—	—	—
	2	—	TC	—	—	—	—	—	—	—	—
	3	—	—	TC	—	—	—	—	—	—	—
	4	—	—	—	TC	—	—	—	—	—	—
	5	—	—	—	—	—	—	—	—	—	—
	6	—	—	—	—	—	—	—	—	—	—
4 x 4 x 8	1	TC	—	—	—	—	—	—	—	—	—
	2	—	TC	—	—	—	—	—	—	—	—
	3	—	—	TC	—	—	—	—	—	—	—
	4	—	—	—	TC	—	—	—	—	—	—
	5	—	—	—	—	—	—	—	—	—	—
	6	—	—	—	—	—	—	—	—	—	—
5 x 5 x 8	1	TC	—	—	—	—	—	—	—	—	—
	2	—	TC	—	—	—	—	—	—	—	—
	3	—	—	TC	—	—	—	—	—	—	—
	4	—	—	—	TC	—	—	—	—	—	—
	5	—	—	—	—	—	—	—	—	—	—
	6	—	—	—	—	—	—	—	—	—	—
6 x 6 x 8	2	—	TC	—	—	—	—	—	—	—	—
	3	—	—	TC	—	—	—	—	—	—	—
	4	—	—	—	TC	—	—	—	—	—	—
8 x 8 x 8	2	—	TC	—	—	—	—	—	—	—	—
	3	—	—	TC	—	—	—	—	—	—	—
	4	—	—	—	TC	—	—	—	—	—	—
	4	—	—	—	—	TC	—	—	—	—	—

4300 POWER FRAMES: ALL SPEEDS (continued)

4300 GROUP NUMBER		1	2	3	4
SEAL SIZE AND PUMP SHAFT DIAMETER		$1\frac{1}{8}$	$1\frac{1}{8}$	$1\frac{1}{8}$	$1\frac{1}{8}$
IMPELLER BORE		$\frac{7}{8}$	$\frac{7}{8}$	$\frac{7}{8}$	$\frac{7}{8}$
COUPLING BORE	MOTOR SHAFT DIAMETER	$\frac{7}{8}$	$1\frac{1}{8}$	$1\frac{3}{8}$	$1\frac{1}{2}$
	PUMP SHAFT DIAMETER	$1\frac{1}{8}$	$1\frac{1}{8}$	$1\frac{1}{8}$	$1\frac{1}{8}$
SHAFT GAP BETWEEN PUMP AND MOTOR		$1\frac{3}{8}$	$2\frac{1}{2}$	2	$1\frac{3}{8}$

CROSS SECTION VIEW

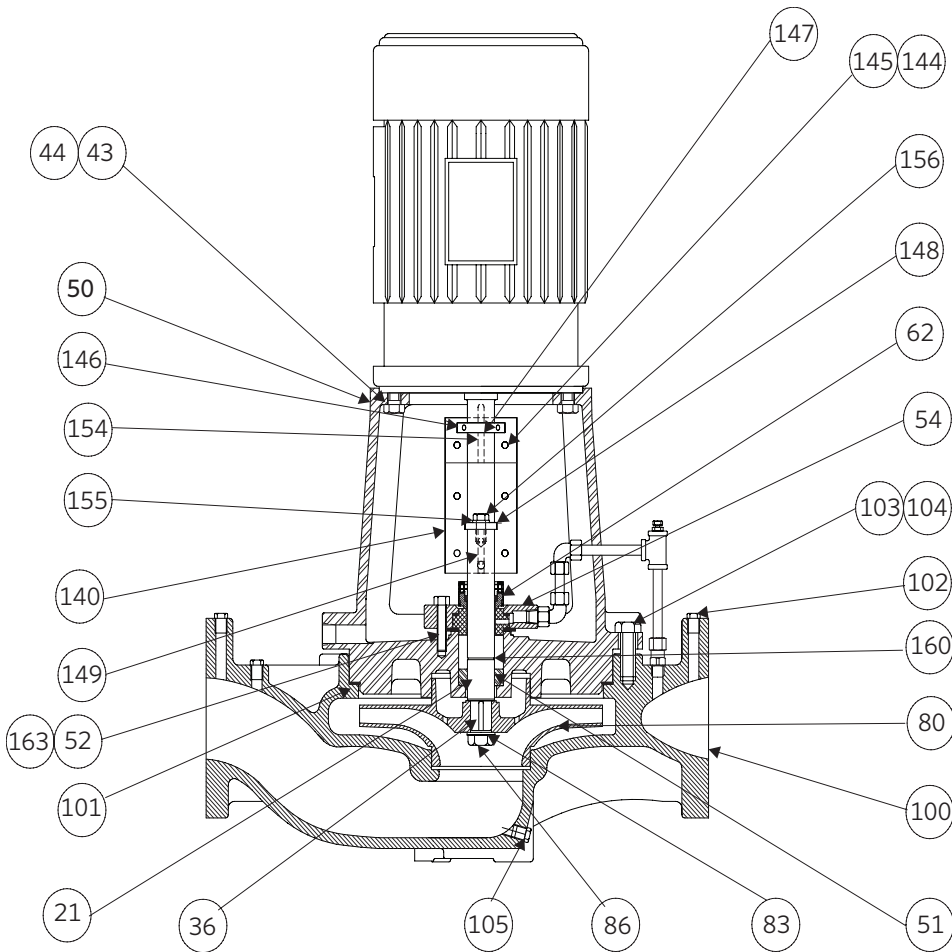

MECHANICAL SEAL

Exploded view

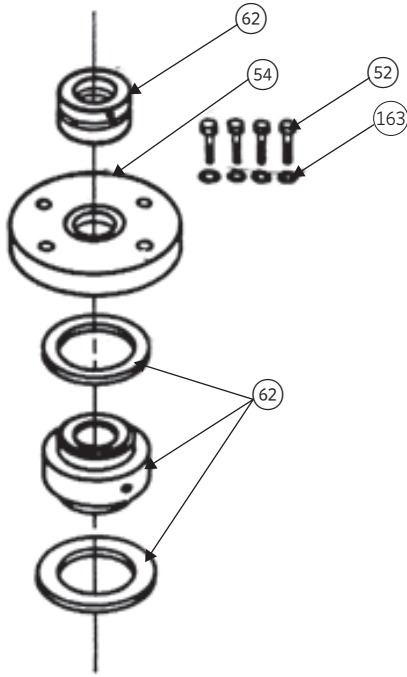

OUTSIDE MECHANICAL SEAL

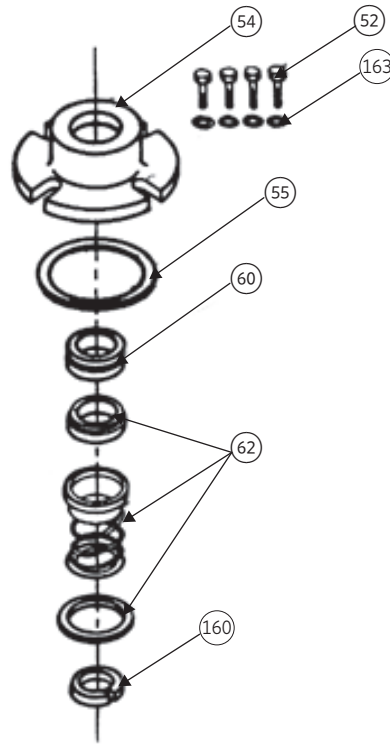

INSIDE MECHANICAL SEAL

INDEX

ITEM	DESCRIPTION	PAGE
21	Shaft	22
36	Impeller key	22
43	Lockwasher	
44	Motor capscrew	18
50	Stuffing box/adapter	14 to 16
51	Seal chamber bushing	22
52	Seal cover capscrew	23
54	Seal cover	22
55	Inside seal cover gasket	23
58	Male straight connector	23
59	Tubing	23
60	Inside seal seat	
62	Outside mechanical seal John crane STD.	22
62	Outside mechanical seal John crane T.C.	22
62	Outside mechanical seal Durametallic STD.	22
62	Outside mechanical seal Durametallic T.C.	22
62	Inside mechanical seal head B.F. & A.I. construction	23
63	1/4" NPT tee	23
68	Air vent	23
80	Impeller	9&10
83	Impeller washer	22
86	Impeller capscrew	22
90	Case wear ring	12&13

ITEM	DESCRIPTION	PAGE
100	Casing	7&8
101	Casing gasket	10
102	Gauge plug	22
103	Casing capscrew washer	11
104	Casing capscrew	11
105	Casing drain plug	12
140	Coupler	21
144	Coupler capscrew	22
145	Lockwasher	22
146	Coupler collar set screw	19
147	Shaft coupler collar	19
148	Motor coupler collar	22
149	Coupler square key (pump)	22
150	Coupling guard (not shown)	17
151	Coupler guard bolt (not shown)	17
152	Nut (not shown)	17
153	Washer (not shown)	17
154	Coup. Square key (motor)	20
155	Capscrew lockwasher	22
156	Shaft capscrew	22
160	Inside seal retaining ring	23
163	Seal cover capscrew washer	23
194	Male 90° angle connection	23

ITEM 100 CASING**

PUMP SIZE	PRESSURE RATING (LB)	CONSTRUCTION	PART NUMBER
1 1/2 x 1 1/2 x 6	125#	Cast iron	427035-011
	250#	Ductile iron	427036-031
	125#	All bronze	427035-041
2 x 2 x 6	125#	Cast iron	427037-011
	250#	Ductile iron	427038-031
	125#	All bronze	427037-041
3 x 3 x 6	125#	Cast iron	427041-011
	250#	Ductile iron	427042-031
	125#	All bronze	427041-041
4 x 4 x 6	125#	Cast iron	427043-011
	250#	Ductile iron	427044-031
	125#	All bronze	427043-041
1 1/2 x 1 1/2 x 8	125#	Cast iron	427045-011
	250#	Ductile iron	427046-031
	125#	All bronze	427045-041
2 x 2 x 8	125#	Cast iron	427047-011
	250#	Ductile iron	427048-031
	125#	All bronze	427047-041
3 x 3 x 8	125#	Cast iron	427051-011
	250#	Ductile iron	427052-031
	125#	All bronze	427051-041
4 x 4 x 8	125#	Cast iron	426241-011 [†]
	250#	Ductile iron	426242-031 [†]
	125#	All bronze	426241-041 [†]
5 x 5 x 8	125#	Cast iron	427024-011
	250#	Ductile iron	427025-031
	125#	All bronze	427024-041
6 x 6 x 8	125#	Cast iron	427055-011
	250#	Ductile iron	427056-031
	125#	All bronze	427055-041
8 x 8 x 8	125#	Cast iron	427915-011
	250#	Ductile iron	427916-031
	125#	All bronze	427915-041
2 x 2 x 10	125#	Cast iron	427059-011
	250#	Ductile iron	427060-031
	125#	All bronze	427059-041

ITEM 100 CASING (continued)**

PUMP SIZE	PRESSURE RATING (LB)	CONSTRUCTION	PART NUMBER
3×3×10	125#	Cast iron	427061-011
	250#	Ductile iron	427062-031
	125#	All bronze	427061-041
4×4×10	125#	Cast iron	427063-011
	250#	Ductile iron	427064-031
	125#	All bronze	427063-041
6×6×10	125#	Cast iron	427065-011
	250#	Ductile iron	427066-031
	125#	All bronze	427065-041
8×8×10	125#	Cast iron	427067-011
	250#	Ductile iron	427068-031
	125#	All bronze	427067-041
4×4×11½	125#	Cast iron	426119-011
	250#	Ductile iron	426120-031
	125#	All bronze	426119-041
5×5×11½	125#	Cast iron	426123-011
	250#	Ductile iron	426124-031
	125#	All bronze	426123-041
6×6×11½	125#	Cast iron	426127-011
	250#	Ductile iron	426128-031
	125#	All bronze	426127-041
8×8×11½	125#	Cast iron	426131-011
	250#	Ductile iron	426132-031
	125#	All bronze	426131-041

NOTES:

** Casing part numbers are for casing only, casing wear ring is sold separately.
 If new casing is required, it must be ordered c/w wear ring.

ITEM 80 IMPELLER 7/8" BORE**

PUMP SIZE	MATERIAL	IMPELLER BORE	MAXIMUM DIAMETER	PART NUMBER
1 1/2 x 1 1/2 x 6	Bronze	7/8"	6"	427099-041
	Cast iron	7/8"	6"	427099-011
2 x 2 x 6	Bronze	7/8"	6"	427109-041
	Cast iron	7/8"	6"	427109-011
3 x 3 x 6	Bronze	7/8"	6"	427103-041
	Cast iron	7/8"	6"	427103-011
4 x 4 x 6	Bronze	7/8"	6"	427115-041
	Cast iron	7/8"	6"	427115-011
1 1/2 x 1 1/2 x 8	Bronze	7/8"	8"	427119-041
	Cast iron	7/8"	8"	427119-011
2 x 2 x 8	Bronze	7/8"	8"	427121-041
	Cast iron	7/8"	8"	427121-011
3 x 3 x 8	Bronze	7/8"	8"	427129-041
	Cast iron	7/8"	8"	427129-011
4 x 4 x 8	Bronze	7/8"	8"	427137-041 [†]
	Cast iron	7/8"	8"	427137-011 [†]
4 x 4 x 8	Bronze	7/8"	8"	426239-041 ^{††}
	Cast iron	7/8"	8"	426239-011 ^{††}
5 x 5 x 8	Bronze	7/8"	8"	427131-041
	Cast iron	7/8"	8"	427131-011
6 x 6 x 8	Bronze	7/8"	8"	427139-041
	Cast iron	7/8"	8"	427139-011
8 x 8 x 8	Bronze	7/8"	8"	427917-041
	Cast iron	7/8"	8"	427917-011
2 x 2 x 10	Bronze	7/8"	10"	427151-041
	Cast iron	7/8"	10"	427151-011
3 x 3 x 10	Bronze	7/8"	10"	427163-041
	Cast iron	7/8"	10"	427163-011
4 x 4 x 10	Bronze	7/8"	10"	427149-041
	Cast iron	7/8"	10"	427149-011
6 x 6 x 10	Bronze	7/8"	10"	427153-041
	Cast iron	7/8"	10"	427153-011
8 x 8 x 10	Bronze	7/8"	10"	427156-041
	Cast iron	7/8"	10"	427156-011
4 x 4 x 11 1/2	Bronze	7/8"	11 1/2"	426281-041
	Cast iron	7/8"	11 1/2"	426281-011
5 x 5 x 11 1/2	Bronze	7/8"	11 1/2"	426283-041
	Cast iron	7/8"	11 1/2"	426283-011

10

ITEM 80 IMPELLER 7/8" BORE (continued)**

PUMP SIZE	MATERIAL	IMPELLER BORE	MAXIMUM DIAMETER	PART NUMBER
6×6×11 1/2	Bronze	7/8"	11 1/2"	426290-041
	Cast iron	7/8"	11 1/2"	426290-011
8×8×11 1/2	Bronze	7/8"	11 1/2"	426294-041
	Cast iron	7/8"	11 1/2"	426294-011

NOTES:

** Impeller part numbers are for full or maximum diameter impellers. Always specify pump serial number and where possible, measure and advise the diameter of the Impeller being replaced on these Pumps.

† For pre-July 2010 pumps

†† For post-July 2010 pumps (**do not** use for Twin or DualArm 6×6×8)

ITEM 101 CASING GASKET

PUMP SIZE	CONSTRUCTION	PART NUMBER
1 1/2×1 1/2×6	ALL	426401-002
2×2×6		
3×3×6		
4×4×6		
1 1/2×1 1/2×8	ALL	426401-003
2×2×8		
3×3×8		
4×4×8		
5×5×8		
6×6×8		
8×8×8	ALL	426401-004
2×2×10		
3×3×10		
4×4×10		
6×6×10	ALL	426401-006
8×8×10		
4×4×11 1/2		
5×5×11 1/2		
6×6×11 1/2	ALL	426401-006
8×8×11 1/2		

ITEM 103 CASING CAPSCREW & ITEM 104 WASHER

PUMP SIZE	NUMBER REQUIRED	SIZE	PART NUMBER
1 1/2 x 1 1/2 x 6	8	CAPSCREW 1/2-13NC x 1 1/4"	911125-110
2 x 2 x 6			
3 x 3 x 6	8	LOCKWASHER 1/2"	927213-100
4 x 4 x 6			
1 1/2 x 1 1/2 x 8	8	CAPSCREW 5/8-11NC x 1 1/2"	911129-112
2 x 2 x 8			
3 x 3 x 8			
4 x 4 x 8			
5 x 5 x 8	8	WASHER 5/8" FLAT	927121-100
6 x 6 x 8			
8 x 8 x 8			
2 x 2 x 10	12	CAPSCREW 5/8-11NC x 1 1/2"	911129-112
3 x 3 x 10	12	WASHER 5/8" FLAT	927121-100
4 x 4 x 10	12	CAPSCREW 5/8-11NC x 1 3/4"	911129-114
	12	LOCKWASHER 5/8"	927215-100
6 x 6 x 10	12	CAPSCREW 5/8-11NC x 1 1/2"	911129-112
8 x 8 x 10	12	WASHER 5/8" FLAT	927121-100
4 x 4 x 11 1/2	16	CAPSCREW 1/2-13NC x 1 1/2"	911125-112
5 x 5 x 11 1/2			
6 x 6 x 11 1/2	16	WASHER 1/2" FLAT	927117-100
8 x 8 x 11 1/2			

ITEM 105 CASING DRAIN PLUG

PUMP SIZE	MATERIAL	NUMBER REQUIRED	SIZE	PART NUMBER
1 1/2 x 1 1/2 x 6	CAD PLATED	1	1/4" NPT	937105-201
2 x 2 x 6				
3 x 3 x 6				
4 x 4 x 6				
1 1/2 x 1 1/2 x 8				
2 x 2 x 8				
3 x 3 x 8				
4 x 4 x 8				
6 x 6 x 8				
8 x 8 x 8				
2 x 2 x 10				
3 x 3 x 10				
4 x 4 x 10				
8 x 8 x 10				
5 x 5 x 8	CAD PLATED	1	1/2" NPT	937105-203
6 x 6 x 10				
4 x 4 x 11 1/2	CAD PLATED	1	1/4" NPT	937105-201
5 x 5 x 11 1/2				
6 x 6 x 11 1/2	CAD PLATED	1	1/2" NPT	937105-203
8 x 8 x 11 1/2				

ITEM 90 CASE WEAR RING

PUMP SIZE	MATERIAL	PART NUMBER
1 1/2 x 1 1/2 x 6	SAE 660 BRONZE	426413-401
	CLASS 30 C.I.	426413-101
2 x 2 x 6	SAE 660 BRONZE	426413-403
	CLASS 30 C.I.	426413-103
3 x 3 x 6	SAE 660 BRONZE	426413-406
	CLASS 30 C.I.	426413-106
4 x 4 x 6	SAE 660 BRONZE	426413-404
	CLASS 30 C.I.	426413-104
1 1/2 x 1 1/2 x 8	SAE 660 BRONZE	426413-402
	CLASS 30 C.I.	426413-102

ITEM 90 CASE WEAR RING (continued)

PUMP SIZE	MATERIAL	PART NUMBER
2×2×8	SAE 660 BRONZE	426413-404
	CLASS 30 C.I.	426413-104
3×3×8	SAE 660 BRONZE	426413-407
	CLASS 30 C.I.	426413-107
4×4×8	SAE 660 BRONZE	426413-410
	CLASS 30 C.I.	426413-110
5×5×8	SAE 660 BRONZE	426413-413
	CLASS 30 C.I.	426413-113
6×6×8	SAE 660 BRONZE	426413-404
	CLASS 30 C.I.	426413-104
8×8×8	SAE 660 BRONZE	
	CLASS 30 C.I.	
2×2×10	SAE 660 BRONZE	426413-404
	CLASS 30 C.I.	426413-104
3×3×10	SAE 660 BRONZE	426413-404
	CLASS 30 C.I.	426413-104
4×4×10	SAE 660 BRONZE	426413-408
	CLASS 30 C.I.	426413-108
6×6×10	SAE 660 BRONZE	426413-412
	CLASS 30 C.I.	426413-112
8×8×10	SAE 660 BRONZE	426413-414
	CLASS 30 C.I.	426413-114
4×4×11½	SAE 660 BRONZE	426412-405
	CLASS 30 C.I.	426412-105
5×5×11½	SAE 660 BRONZE	426412-411
	CLASS 30 C.I.	426413-111
6×6×11½	SAE 660 BRONZE	426412-420
	CLASS 30 C.I.	426412-120
8×8×11½	SAE 660 BRONZE	426412-421
	CLASS 30 C.I.	426412-121

ITEM 50 ADAPTER

Bronze fitted and All iron construction

PUMP SIZE	MOTOR FRAME SIZE	MATERIAL	PART NUMBER
1 1/2 x 1 1/2 x 6	143 - 145TC	CAST IRON	427700-011
2 x 2 x 6			
3 x 3 x 6	182 - 256TC		427703-011
4 x 4 x 6			
1 1/2 x 1 1/2 x 8	143 - 145TC	CAST IRON	427701-011
2 x 2 x 8			
3 x 3 x 8			
4 x 4 x 8			
5 x 5 x 8	182 - 256TC		427704-011
6 x 6 x 8			
8 x 8 x 8			
2 x 2 x 10	143 - 145TC	CAST IRON	427702-011
3 x 3 x 10			
4 x 4 x 10			
6 x 6 x 10	182 - 256TC		427705-011
8 x 8 x 10			
4 x 4 x 11 1/2	182 - 256TC	CAST IRON	427706-011
5 x 5 x 11 1/2			
6 x 6 x 11 1/2			
8 x 8 x 11 1/2			

ITEM 50 ADAPTER

Ductile iron and Ductile bronze fitted construction

PUMP SIZE	MOTOR FRAME SIZE	MATERIAL	PART NUMBER
1 1/2 x 1 1/2 x 6	143 - 145TC	CAST IRON	427700-031
2 x 2 x 6			
3 x 3 x 6	182 - 256TC		427703-031
4 x 4 x 6			
1 1/2 x 1 1/2 x 8	143 - 145TC	CAST IRON	427701-031
2 x 2 x 8			
3 x 3 x 8	182 - 256TC		427704-031
4 x 4 x 8			
5 x 5 x 8	182 - 256TC	427704-031	
6 x 6 x 8			
8 x 8 x 8			
2 x 2 x 10	143 - 145TC	CAST IRON	427702-031
3 x 3 x 10			
4 x 4 x 10	182 - 256TC		427705-031
6 x 6 x 10			
8 x 8 x 10	182 - 256TC	CAST IRON	427706-031
4 x 4 x 11 1/2			
5 x 5 x 11 1/2			
6 x 6 x 11 1/2			
8 x 8 x 11 1/2			

ITEM 50 ADAPTER

All bronze construction

PUMP SIZE	MOTOR FRAME SIZE	MATERIAL	PART NUMBER
1 1/2 x 1 1/2 x 6	143 - 145TC	CAST BRONZE	427700-041
2 x 2 x 6			
3 x 3 x 6	182 - 256TC		427703-041
4 x 4 x 6			
1 1/2 x 1 1/2 x 8	143 - 145TC	CAST BRONZE	427701-041
2 x 2 x 8			
3 x 3 x 8			
4 x 4 x 8			
5 x 5 x 8	182 - 256TC		427704-041
6 x 6 x 8			
8 x 8 x 8			
2 x 2 x 10	143 - 145TC	CAST BRONZE	427702-041
3 x 3 x 10			
4 x 4 x 10			
6 x 6 x 10	182 - 256TC		427705-041
8 x 8 x 10			
4 x 4 x 11 1/2	182 - 256TC	CAST BRONZE	427706-041
5 x 5 x 11 1/2			
6 x 6 x 11 1/2			
8 x 8 x 11 1/2			

ITEM 150 COUPLER GUARD

PUMP SIZE	MOTOR FRAME SIZE	PART NUMBER
1 1/2 x 1 1/2 x 6	143 - 145TC	427761-001
2 x 2 x 6		
3 x 3 x 6	182 - 256TC	427761-003
4 x 4 x 6		
1 1/2 x 1 1/2 x 8	143 - 145TC	427761-001
2 x 2 x 8		
3 x 3 x 8		
4 x 4 x 8		
5 x 5 x 8	182 - 256TC	427761-004
6 x 6 x 8		
8 x 8 x 8		
2 x 2 x 10	143 - 145TC	427761-002
3 x 3 x 10		
4 x 4 x 10		
6 x 6 x 10	182 - 256TC	427761-005
8 x 8 x 10		
4 x 4 x 11 1/2	182 - 256TC	427761-005
5 x 5 x 11 1/2		
6 x 6 x 11 1/2		
8 x 8 x 11 1/2		

COUPLER GUARD FASTENERS

ITEM NUMBER	DESCRIPTION	NUMBER REQUIRED	SIZE	PART NUMBER
151	Bolt - RD. HD.	2	#8-32 x 1 1/2"	916262-120
152	Nut	2	#8-32	913162-116
153	Washer	2	#8-32	927105-100

ITEM 44 MOTOR CAPSCREW & ITEM 43 LOCKWASHER

PUMP SIZE	MOTOR FRAME SIZE	ITEM DESCRIPTION	PART NUMBER
1 1/2 x 1 1/2 x 6	143 - 145TC	CAPSCREW	911121-108
2 x 2 x 6		LOCKWASHER	927211-100
3 x 3 x 6	182 - 256TC	CAPSCREW	911125-110
4 x 4 x 6		LOCKWASHER	927213-100
1 1/2 x 1 1/2 x 8	143 - 145TC	CAPSCREW	911121-108
2 x 2 x 8		LOCKWASHER	927211-100
3 x 3 x 8	182 - 215TC	LOCKWASHER	927211-100
4 x 4 x 8		CAPSCREW	911125-110
5 x 5 x 8		LOCKWASHER	911125-110
6 x 6 x 8		CAPSCREW	911125-110
8 x 8 x 8		LOCKWASHER	911125-110
2 x 2 x 10	143 - 145TC	CAPSCREW	911121-108
3 x 3 x 10		LOCKWASHER	927211-100
4 x 4 x 10	182-256TC	CAPSCREW	911125-110
6 x 6 x 10		LOCKWASHER	927213-100
8 x 8 x 10		CAPSCREW	911125-110
4 x 4 x 11 1/2	182 - 256TC	LOCKWASHER	927213-110
5 x 5 x 11 1/2		CAPSCREW	911125-110
6 x 6 x 11 1/2		LOCKWASHER	927213-110
8 x 8 x 11 1/2		CAPSCREW	911125-110

ITEM 147 MOTOR COUPLER COLLAR

PUMP SIZE	MOTOR FRAME SIZE	PART NUMBER
1 1/2 x 1 1/2 x 6	143 - 145TC	427748-000
2 x 2 x 6	182 - 184TC	427749-000
3 x 3 x 6	213 - 215TC	427750-000
4 x 4 x 6	254 - 256TC	427751-000
1 1/2 x 1 1/2 x 8	143 - 145TC	427748-000
2 x 2 x 8	182 - 184TC	427749-000
3 x 3 x 8	213 - 215TC	427750-000
4 x 4 x 8	254 - 256TC	427751-000
5 x 5 x 8	213 - 215TC	427750-000
6 x 6 x 8	254 - 256TC	427751-000
8 x 8 x 8	254 - 256TC	427751-000
2 x 2 x 10	143 - 145TC	427748-000
3 x 3 x 10	182 - 184TC	427749-000
4 x 4 x 10	213 - 215TC	427750-000
6 x 6 x 10	254 - 256TC	427751-000
8 x 8 x 10	254 - 256TC	427751-000
4 x 4 x 11 1/2	213 - 215TC	427750-000
5 x 5 x 11 1/2	213 - 215TC	427750-000
6 x 6 x 11 1/2	254 - 256TC	427751-000
8 x 8 x 11 1/2	254 - 256TC	427751-000

ITEM 146 MOTOR COUPLER COLLAR SET SCREW

PUMP SIZE	MOTOR FRAME SIZE	PART NUMBER
ALL	143 - 215TC	916517-106
	254 - 256TC	916519-106

ITEM 154 MOTOR KEY

PUMP SIZE	MOTOR FRAME SIZE	PART NUMBER
1 1/2 x 1 1/2 x 6	143 - 145TC	428160-708
2 x 2 x 6	182 - 184TC	428161-712
3 x 3 x 6	213 - 215TC	428162-115
4 x 4 x 6	254 - 256TC	428163-714
1 1/2 x 1 1/2 x 8	143 - 145TC	428160-708
2 x 2 x 8	182 - 184TC	428161-712
3 x 3 x 8	213 - 215TC	428162-115
4 x 4 x 8	254 - 256TC	428163-714
5 x 5 x 8	213 - 215TC	428162-115
6 x 6 x 8	254 - 256TC	428163-714
8 x 8 x 8	254 - 256TC	428163-714
2 x 2 x 10	143 - 145TC	428160-708
3 x 3 x 10	182 - 184TC	428161-712
4 x 4 x 10	213 - 215TC	428162-115
6 x 6 x 10	254 - 256TC	428163-714
8 x 8 x 10	254 - 256TC	428163-714
4 x 4 x 11 1/2	213 - 215TC	428162-115
5 x 5 x 11 1/2	213 - 215TC	428162-115
6 x 6 x 11 1/2	254 - 256TC	428163-714
8 x 8 x 11 1/2	254 - 256TC	428163-714

ITEM 140 COUPLER

PUMP SIZE	MOTOR FRAME SIZE	PART NUMBER
1 1/2 x 1 1/2 x 6	143 - 145TC	427731-000
2 x 2 x 6	182 - 184TC	427732-000
3 x 3 x 6	213 - 215TC	427733-000
4 x 4 x 6	254 - 256TC	427734-000
1 1/2 x 1 1/2 x 8	143 - 145TC	427731-000
2 x 2 x 8	182 - 184TC	427732-000
3 x 3 x 8	213 - 215TC	427733-000
4 x 4 x 8	254 - 256TC	427734-000
5 x 5 x 8	213 - 215TC	427733-000
6 x 6 x 8	254 - 256TC	427734-000
8 x 8 x 8	254 - 256TC	427734-000
2 x 2 x 10	143 - 145TC	427731-000
3 x 3 x 10	182 - 184TC	427732-000
4 x 4 x 10	213 - 215TC	427733-000
6 x 6 x 10	254 - 256TC	427734-000
8 x 8 x 10	254 - 256TC	427734-000
4 x 4 x 11 1/2	213 - 215TC	427733-000
5 x 5 x 11 1/2	213 - 215TC	427733-000
6 x 6 x 11 1/2	254 - 256TC	427734-000
8 x 8 x 11 1/2	254 - 256TC	427734-000

COMMON PARTS

All constructions

ITEM NUMBER	DESCRIPTION	PART NUMBER
21	1 1/8" Pump shaft	427713-000
36	Impeller key	428160-708
51	Seal chamber bushing	425520-002
83	Impeller washer	425742-001
86	Impeller capscrew	911900-114
102	Gauge plug (4 required) 1/4" NPT. CAD plated	937105-201
144	Coupler capscrew (6 required) Frames 143 to 215TC	911819-112
144	Coupler capscrew (6 required) Frame 254/256TC	911821-116
145	Lockwasher (for item 144) Frames 143 TO 215TC (6 required)	927210-100
145	Lockwasher (for item 144) Frame 254/256TC	927211-100
148	Coupler collar (pump shaft)	427756-000
149	Cplr. Key (pump shaft)	428161-106
155	Capscrew lockwasher	927211-400
156	Collar capscrew	911121-106

PARTS FOR 1 1/8" OUTSIDE SEAL

ITEM NUMBER	DESCRIPTION	CONSTRUCTION	PART NUMBER
62	Mechanical seal		
	Armstrong seal	All	975002-304
	Durametallic STD.	All	975002-003
	Durametallic T.C.	All	975002-001
	John crane STD.	All	975000-955
	John crane T.C.	All	975000-965
103	Capscrew - 4 required 3/8" -16NCx1 1/2" S/S	All	911121-416
104	Washer - 4 required 3/8" FLAT	All	427114-100
54	Seal cover	Bronze fitted, All bronze, Ductile bronze fitted	426484-002
		All iron, Ductile iron	426484-001

PARTS FOR 1 1/8" INSIDE MECHANICAL SEAL ARRANGEMENT

ITEM NUMBER	DESCRIPTION	CONSTRUCTION	PART NUMBER
62	Mechanical seal	All	810150-143
52	Capscrew - 4 required 3/8"-16NCx1" S/S	All	911121-408
163	Washer - 4 required 3/8" FLAT	All	427114-100
54	Seal cover	Bronze fitted, All bronze, Ductile bronze fitted	426464-011
		All iron, Ductile iron	426464-001
55	Gasket	All	426467-001
160	Retaining ring	All	923104-434

STANDARD MECHANICAL SEAL FLUSH LINE PARTS

ITEM NUMBER	DESCRIPTION	NUMBER REQUIRED	CONSTRUCTION	PART NUMBER
58	MALE STRAIGHT CONNECTION 3/8" TUBE x 1/4" NPT	1	Bronze fitted, All bronze, Ductile bronze fitted	939001-114
			All iron, Ductile iron	939001-314
59	TUBING 20" REQUIRED 3/8" OD x .035 WALL	20"	Bronze fitted, All bronze, Ductile bronze fitted	997531-004
			All iron, Ductile iron	997153-004
63	TEE 1/4" NPT	1	Bronze fitted, All bronze, Ductile bronze fitted	935101-001
			All iron, Ductile iron	931101-101
64	BUSHING 1/4" MNPT x 1/8" FNPT	1	Bronze fitted, All bronze, Ductile bronze fitted	935123-050
			All iron, Ductile iron	931123-150
67	NIPPLE 1/4" NPT x 2 1/2" NPT	1	Bronze fitted, All bronze, Ductile bronze fitted	938103-001
			All iron, Ductile iron	938003-101
68	AIR VENT	1	Bronze fitted, All bronze, Ductile bronze fitted	939018-101
			All iron, Ductile iron	218644-000
194	MALE 90° CONNECTION 3/8" TUBE x 1/4" NPT	1	Bronze fitted, All bronze, Ductile bronze fitted	939003-109
			All iron, Ductile iron	939003-309

FOR OTHER FLUSH LINE OPTIONS, SEE FLUSH LINE OPTIONS PARTS LIST

TORONTO

23 BERTRAND AVENUE
TORONTO, ONTARIO
CANADA
M1L 2P3
+1 416 755 2291

BUFFALO

93 EAST AVENUE
NORTH TONAWANDA, NEW YORK
U.S.A.
14120-6594
+1 716 693 8813

BIRMINGHAM

HEYWOOD WHARF, MUCKLOW HILL
HALESOWEN, WEST MIDLANDS
UNITED KINGDOM
B62 8DJ
+44 (0) 8444 145 145

MANCHESTER

WOLVERTON STREET
MANCHESTER
UNITED KINGDOM
M11 2ET
+44 (0) 8444 145 145

BANGALORE

#59, FIRST FLOOR, 3RD MAIN
MARGOSA ROAD, MALLESWARAM
BANGALORE, INDIA
560 003
+91 (0) 80 4906 3555

SHANGHAI

NO. 1619 HU HANG ROAD, XI DU TOWNSHIP
FENG XIAN DISTRICT, SHANGHAI
P.R.C.
201401
+86 21 3756 6696

SÃO PAULO

RUA JOSÉ SEMIÃO RODRIGUES AGOSTINHO,
1370 GALPÃO 6
EMBU DAS ARTES
SAO PAULO, BRAZIL
+55 11 4781 5500

ARMSTRONG FLUID TECHNOLOGY
ESTABLISHED 1934

ARMSTRONGFLUIDTECHNOLOGY.COM

**MAKING
ENERGY
MAKE
SENSE™**