

453-2 (B59)

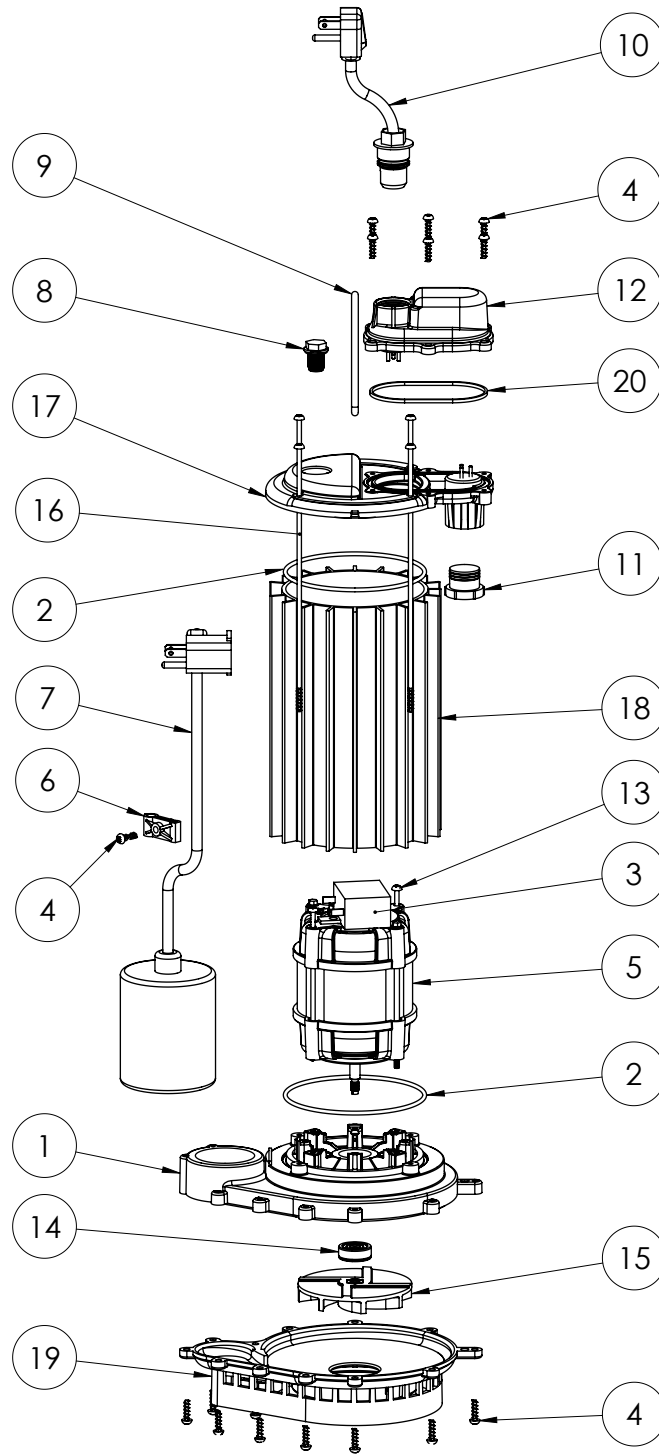

453-2 (B59)

| # | PART # | DESCRIPTION | QTY | Note |
|----|---------|---------------------------------------|-----|------|
| 1 | 23310AB | MOTOR SUPPORT PLATE | 1 | [1] |
| 2 | 2357000 | O-RING | 2 | [1] |
| 3 | 2453000 | CAPACITOR | 1 | [1] |
| 4 | 8104200 | #10 HILO X 5/8" STAINLESS STEEL SCREW | 20 | |
| 5 | 2418200 | MOTOR | 1 | [1] |
| 6 | 2319000 | CLAMP, SWITCH CORD | 1 | |
| 7 | K001054 | 61130A0 PUMP SWITCH, 10' 115V | 1 | |
| 8 | 8089000 | OIL PLUG, O-RING ASSEMBLY | 1 | |
| 9 | K001082 | HANDLE | 1 | |
| 10 | K001008 | POWER CORD, 115V, 25 FOOT CORD | 1 | |
| 11 | 8105000 | PROTECTIVE CAP | 1 | |
| 12 | 240700B | CHAMBER COVER | 1 | |
| 13 | 8148000 | #10 x 4-3/4" POLYFAST SCREW | 1 | [1] |
| 14 | K001254 | 3043000 5/16" SHAFT SEAL | 1 | [1] |
| 15 | K001168 | IMPELLER | 1 | |
| 16 | 8147000 | #10 x 8.4" STAINLESS STEEL SCREW | 4 | [1] |
| 17 | 240600B | MOTOR COVER | 1 | |
| 18 | 23070AS | MOTOR HOUSING | 1 | |
| 19 | 233600B | BASE WITH VOLUTE ASSEMBLY | 1 | |
| 20 | K001046 | SEALRING, CHAMBER COVER | 1 | |

PART NOTES:

[1] - Part requires factory authorized service. Contact Liberty Pumps at 1-800-543-2550