

Series STEP-DS

3/4" Spherical Solids Handling
Double Seal

BARNES®

www.cranepumps.com

Submersible Effluent Pumps

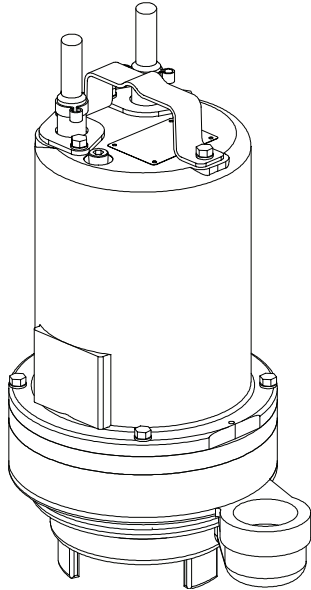

Specifications:

DISCHARGE	2" NPT, Female, Vertical
LIQUID TEMPERATURE	104°F (40°C) Continuous
VOLUTE	Cast Iron ASTM A-48, Class 30
MOTOR HOUSING	Cast Iron ASTM A-48, Class 30
SEAL PLATE	Cast Iron ASTM A-48, Class 30
IMPELLER: Design	Single Vane, Enclosed
Material	Polypropylene with stainless steel insert Dynamically Balanced, ISO G6.3
SHAFT	416 Stainless Steel
SQUARE RINGS	Buna-N
HARDWARE	300 Series Stainless Steel
PAINT	Air Dry Enamel
SEAL: Design	Tandem Mechanical, Oil Filled reservoir
Material	Carbon/Ceramic/Buna-N Hardware -300 Series Stainless
CORD ENTRY	20 ft. (6.1m) Cord with plug on 120 volt & 240 volt, 1 phase. Quick connect custom molded for sealing and strain relief
UPPER BEARING	Single Row, Ball, Oil lubricated
LOWER BEARING	Single Row, Ball, Oil lubricated
MOTOR: Design	NEMA L -Single Phase, NEMA B -Three Phase Torque Curve, Oil Filled, Squirrel Cage Induction
Insulation	Class B
SINGLE PHASE	Permanent Split Capacitor (PSC) Includes Overload Protection in Motor
THREE PHASE	200-240/480 is Tri-Voltage. 600V. Requires Overload Protection to be included in control panel
OPTIONAL EQUIPMENT	Seal Material, Impeller Trims, Additional cord, Normally Closed Temperature Sensors with cord for 3 phase pumps (Requires relay in control panel), Normally Open Moisture Sensors with cord (Requires relay in control panel).

RECOMMENDED:

Accessories	Break Away Fitting (BAF) Check Valve Control Panel
Seal Kit PN	130176
Service Kit PN	130172

Series: STEP-DS .5 & 1HP, 3450RPM, 60Hz



Sample Specifications: Section 3 Page 3.

DESCRIPTION:

PUMP IS DESIGNED FOR HANDLING SEWAGE EFFLUENT IN TYPICAL SEPTIC TANK/EFFLUENT APPLICATIONS.

SECTION 3A
PAGE 4
DATE 6/10

CRANE®

A Crane Co. Company

PUMPS & SYSTEMS

USA: (937) 778-8947 • Canada: (905) 457-6223 • International: (937) 615-3598

Submersible Effluent Pumps

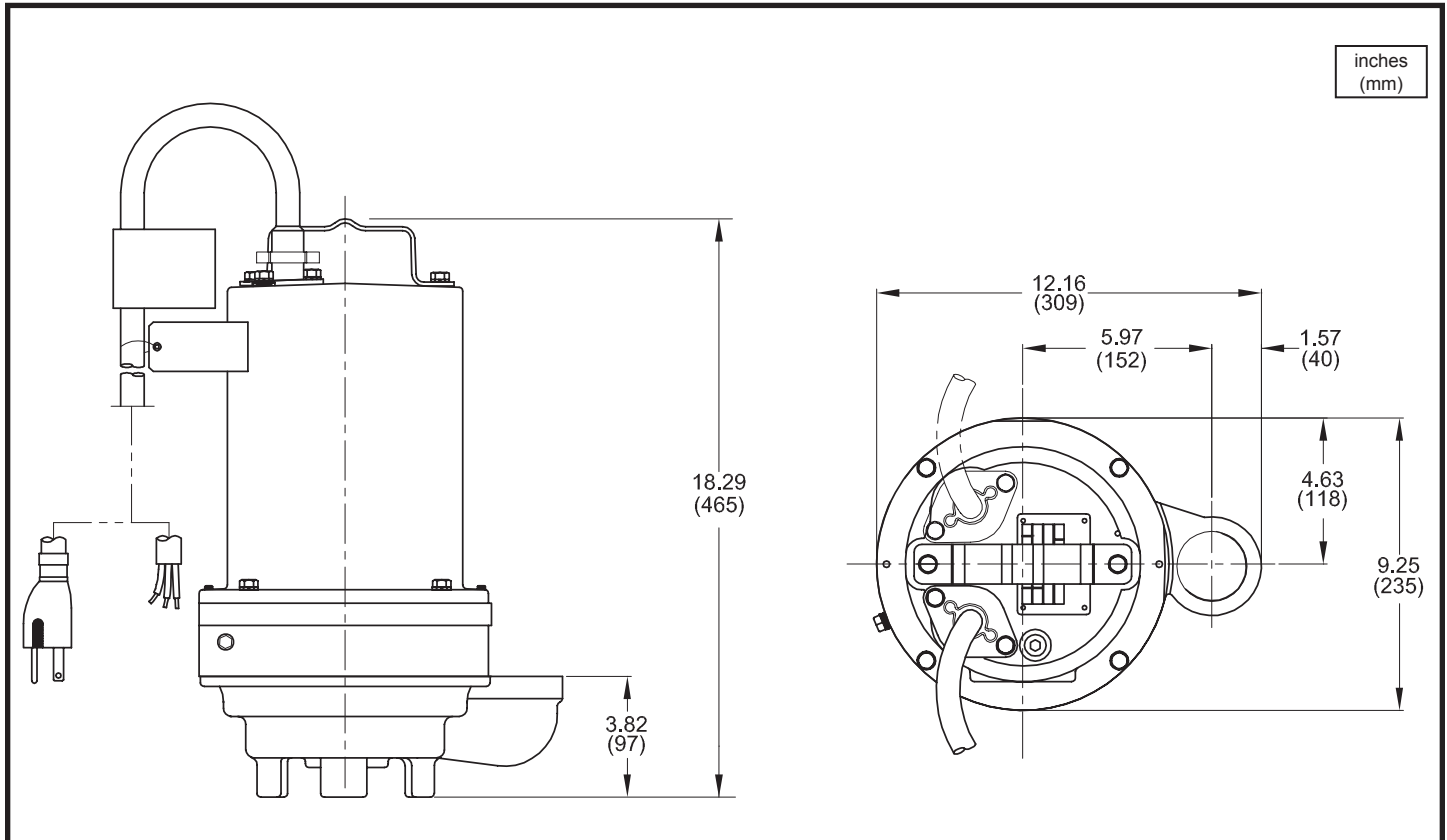

MODEL NO	PART NO	HP	VOLT/PH	Hz	RPM (Nom)	NEMA START CODE	FULL LOAD AMPS	LOCKED ROTOR AMPS	CORD SIZE	CORD TYPE	CORD O.D. inch (mm)
STEP512DS	105040	0.5	120/1	60	3450	G	11.9	24.6	14/3	SJTOW	0.375 (9.5)
STEP522DS	105041	0.5	240/1	60	3450	E	5.1	10.2	14/3	SOW	0.530 (13.5)
STEP592DS	105042	0.5	200/240/3	60	3450	P/R	4.5/4.5	19.9/18.4	14/4	SOW	0.570 (14.5)
STEP542DS	105043	0.5	480/3	60	3450	R	2.2	9.1	14/4	SOW	0.570 (14.5)
STEP552DS	105044	0.5	600/3	60	3450	T	1.8	8.7	14/4	SOW	0.570 (14.5)
STEP1022DS	105050	1.0	240/1	60	3450	F	8.3	21.8	14/3	SOW	0.530 (13.5)
STEP1092DS	105051	1.0	200/240/3	60	3450	H/J	5.9/5.6	19.9/18.4	14/4	SOW	0.570 (14.5)
STEP1042DS	105052	1.0	480/3	60	3450	J	2.8	9.1	14/4	SOW	0.570 (14.5)
STEP1052DS	105053	1.0	600/3	60	3450	L	2.2	8.7	14/4	SOW	0.570 (14.5)

OPTIONAL - Temperature sensor cord for 3 phase models is 14/3 SOW, .530 (13.5mm) O.D.

OPTIONAL - Moisture sensor cord is 18/5 SOW, 0.470 (11.9mm) O.D.

OPTIONAL - Moisture and Temperature sensor cord for 3 phase models is 18/5 SOW, 0.470 (11.9mm) O.D.

IMPORTANT !

- 1.) PUMP MAY BE OPERATED "DRY" FOR EXTENDED PERIODS WITHOUT DAMAGE TO MOTOR AND/OR SEALS.
- 2.) INSTALLATIONS SUCH AS DECORATIVE FOUNTAINS OR WATER FEATURES PROVIDED FOR VISUAL ENJOYMENT MUST BE INSTALLED IN ACCORDANCE WITH THE NATIONAL ELECTRIC CODE ANSI/NFPA 70 AND/OR THE AUTHORITY HAVING JURISDICTION. THIS PUMP IS NOT INTENDED FOR USE IN SWIMMING POOLS, RECREATIONAL WATER PARKS, OR INSTALLATIONS IN WHICH HUMAN CONTACT WITH PUMPED MEDIA IS A COMMON OCCURRENCE.

Series STEP-DS

Performance Curve
 .5 & 1HP, 3450RPM, 60Hz

BARNES®

www.cranepumps.com

Submersible Effluent Pumps

TOTAL HEAD
 MTRS FT

inches
 (mm)

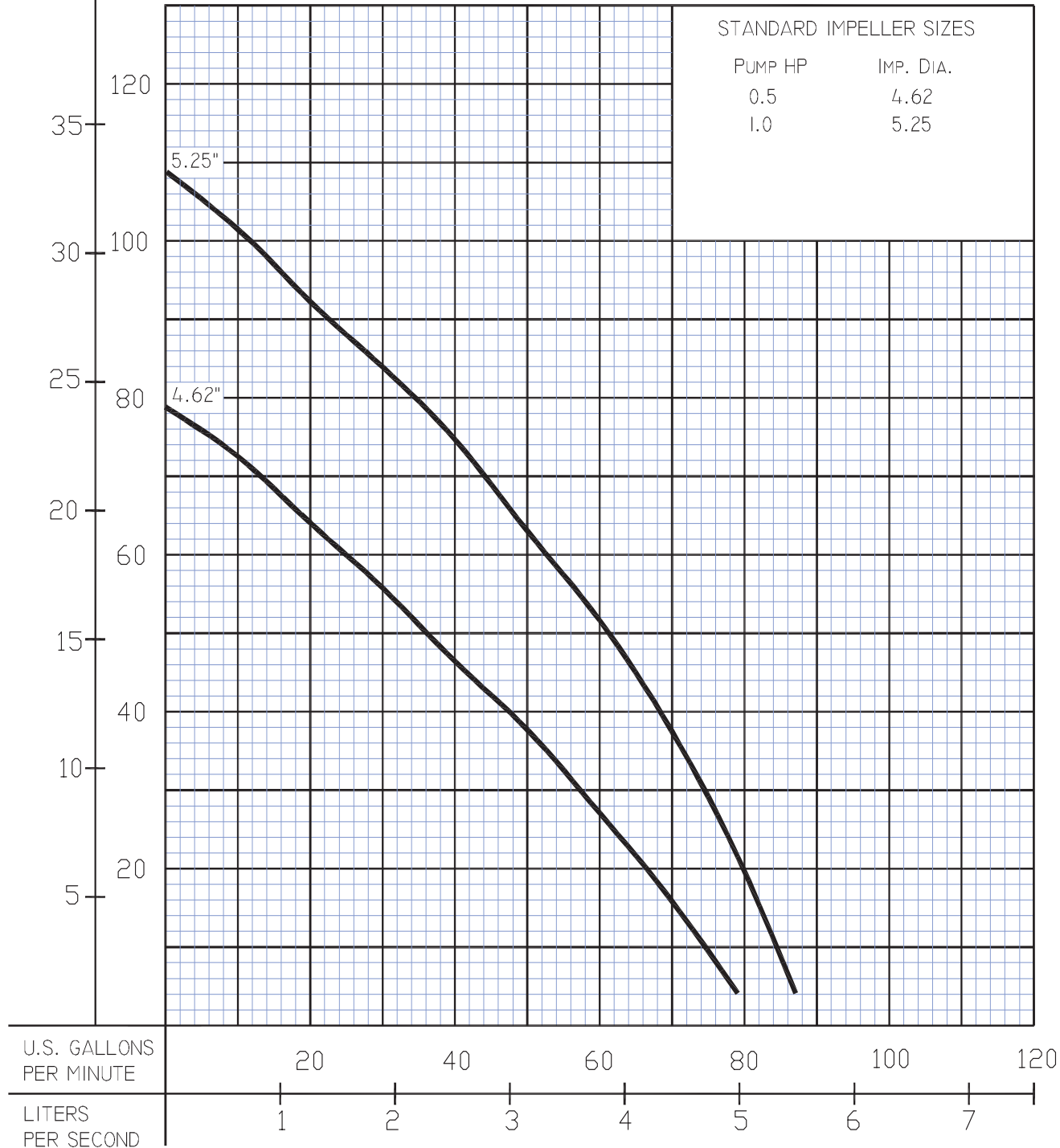

Testing is performed with water, specific gravity 1.0 @ 68° F @ (20°C), other fluids may vary performance

SECTION 3A
 PAGE 6
 DATE 6/04

CRANE
 A Crane Co. Company

PUMPS & SYSTEMS

USA: (937) 778-8947 • Canada: (905) 457-6223 • International: (937) 615-3598