

BERKELEY® SSHM-2 Series

Self-Priming, Multi-Stage Centrifugal Pumps



The SSHM-2 stainless steel self-priming pumps are the first to deliver high-pressure performance without priming problems and delays.

APPLICATIONS

- Irrigation systems
- Water supply systems
- Shower and washing systems
- Heating and air conditioning systems
- Fountains

ORDERING INFORMATION

HP	Voltage/Phase	Catalog No.	List Price	Weight (Lbs.)	Max. Working Pressure	Suction	Discharge	Stages
2	230-1	B86073	\$1,302	95	130 Lbs.	1-1/2"	1-1/4"	3
2	230/460-3 TEFC	B86074	1,484					
2	230-1	B82456-01	1,445					4
2	230/460-3 TEFC	B82639	1,650					

SPECIFICATIONS

Motor Bracket and Integral Pump Base – Close-grained cast iron, 1-1/2" NPT inlet connection, stable heavy-duty design for rigid pipe and solid base mountings

Discharge – Close-grained cast iron, 1-1/4" NPT discharge connection, with easy-access drain port for end of season draining and winterization

Impellers and Diffusers – Noryl® precision-molded extra-smooth ports to maximize efficiency and performance

Outer Shell – Polished 304 stainless steel

Shaft – 303 stainless steel

Priming Valve – Special brass priming valve for trouble-free operation during the initial pump priming

Mechanical Seal – High-pressure seal, carbon-ceramic seal faces, Buna-N elastomers

Heavy-Duty Motor – 2 HP, single-phase, 3450 RPM, 230-volt, high-service factor, capacitor-start/capacitor-run, open drip-proof motor, rated for continuous-duty operation. 230/460 TEFC available

Maximum Inlet Pressure – 20 PSI

Maximum Discharge Pressure – 130 PSI

Maximum Operating Temperature – 120°F (49°C)

Maximum Suction Lift – 15 feet

Number of Stages – 3 or 4

BERKELEY® SSHM-2 Series Self-Priming, Multi-Stage Centrifugal Pumps

PUMP PERFORMANCE

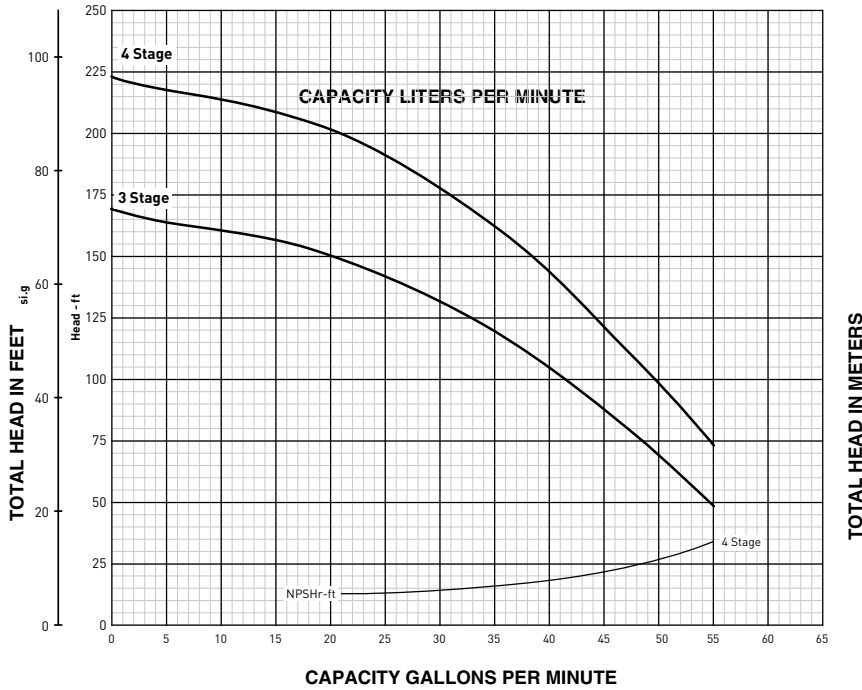

NOTE: Dotted lines indicate performance reduction at high suction lift.

PUMP PERFORMANCE (Capacity in Gallons Per Minute)

Catalog Number	Phase	Stage	HP	Discharge Pressure		Suction Lift in Feet			
				PSI	Feet Head	5'	10'	15'	20'
B82456 B82639	1 3	4	2	20	46	57	54	47	40
				30	69	56	53	46	39
				40	92	52	50	44	39
				50	115	47	46	43	38
				60	138	43	42	41	37
B86073 B86074	1 3	3	2	20	46	55.9	53.8	52.0	50.4
				30	69	48.2	47.0	45.9	44.8
				40	92	43.1	42.0	40.8	39.4
				50	115	36.9	35.1	33.0	30.6
				60	138	26.0	22.7	19.0	14.8

OUTLINE DIMENSIONS

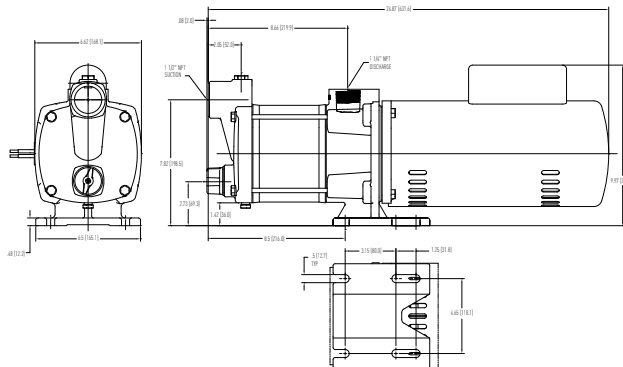

Dimensions (in inches) are for estimating purposes only.



293 WRIGHT STREET, DELAVAN, WI 53115 WWW.BERKELEYPUMPS.COM PH: 888-782-7483 ORDERS FAX: 800-426-9446
Because we are continuously improving our products and services, Pentair reserves the right to change specifications without prior notice.