

## Turbine

### MODEL: SM1 60 HZ GENERAL PUMP DESCRIPTION

Construction:	Cast iron stainless steel fitted
Capacity:	50 - 225 GPM
Head:	50-880 feet
Staging:	1-8
Minimum flow:	50 GPM
Maximum working pressure:	175 PSI with ANSI Class 125 flange (up to 3 stage) 400 PSI with ANSI Class 250 flange (More than 3 stage)
Temperatures:	Liquid temperature from -13°F (-25°C) to 150°F (65°C)
Solids handling:	Although not recommended, the pump may pass a 1/8" solid.
Piping Connections:	Suction and discharge openings are 3" with ANSI Class 125 or 250 flanges.

Component Description	Material	ASTM Spec.
Motor Support	Cast Iron	A48 Class 30
Shaft Coupling	Cast Iron	A48 Class 30
Mechanical Seal	Type 316SS, Carbon Silicon Carbide	
Seal Cover	Cast Iron	A48 Class 30
Casing	Steel or Type 316SS	A53 Grade A or A312 S31600
Casing and Suction O-ring	Nitrile	D2000 2BG715B14
Pump Shaft	Type 416SS	A582 S41600
Intermediate Bowl	Cast Iron	A48 Class 30
Bowl Bearing	Bronze	B854 C90300
Impeller	Type 316SS	A744 CF8M
Taperlock	Type 316SS	A276 S31600
Suction Cover	Cast Iron	A48 Class 30
Pump Body	Cast Iron	A48 Class 30
Hex Head Capscrew	Steel	SAE J429 Gr. 8
Socket Head Capscrew	Steel	SAE J429 Gr. 8
Washer	Steel	A108 G10180
Pipe Plug	Malleable Iron	A197

### MOTORS

Standard motors supplied by Goulds Water Technology are NEMA standard TC frame motors open drip proof, or totally enclosed fan cooled enclosures. 60 Hz, 2-pole, three phase with 1.15 S.F. For other motor options, contact the factory.

### DIMENSIONS AND WEIGHTS

(All dimensions are in inches, weights are total unit weight.)

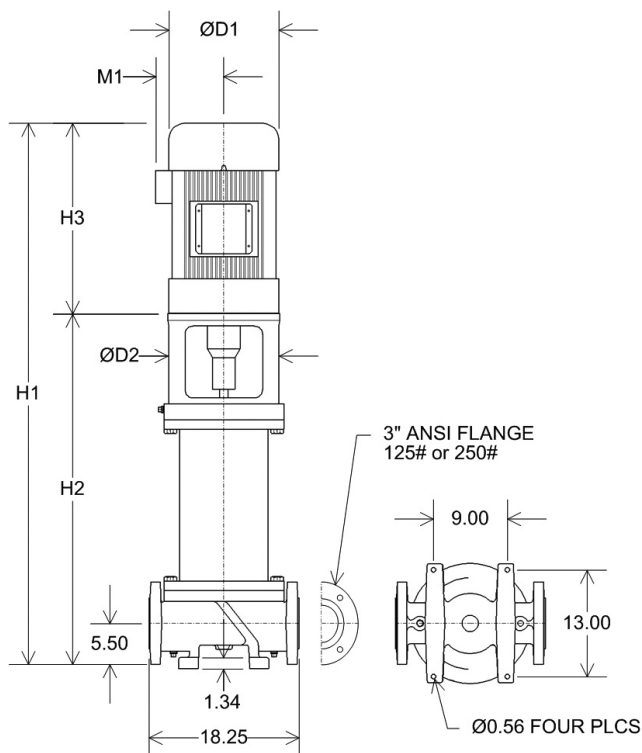

### ODP Motors

Stage	Motor		Dimensions (inches)						Wt. (lbs.)
	Frame	HP	H1	H2	H3	M1	D1	D2	
1	182TC	5*	43.25	29.57	13.68	6.87	8.49	13.63	439
2	213TC	10*	50.37	35.07	15.30	7.93	10.18	13.63	527
3	215TC	15*	55.88	40.57	15.31	7.93	10.18	13.63	593
4	254TC	20*	61.44	46.13	15.31	7.93	10.18	13.63	612
5	256TC	25*	71.07	51.63	19.44	8.92	11.63	13.63	693
6	284TSC	30*	77.69	57.13	20.56	8.94	11.50	13.63	797
7	286TSC	40	85.69	62.69	23.00	12.21	13.25	13.63	952
8	286TSC	40*	91.25	68.25	23.00	12.21	13.25	13.63	1000

### TEFC Motors

Stage	Motor		Dimensions (inches)						Wt. (lbs.)
	Frame	HP	H1	H2	H3	M1	D1	D2	
1	184TC	5*	44.75	29.57	15.18	6.87	8.60	13.63	439
2	215TC	10*	52.07	35.07	17.00	8.05	10.62	13.63	536
3	215TC	15*	57.57	40.57	17.00	8.05	10.62	13.63	666
4	256TC	20*	68.1	46.13	21.97	10.04	12.94	13.63	687
5	284TSC	25*	77.32	51.63	25.69	13.11	15.56	13.63	886
6	286TSC	30*	82.82	57.13	25.69	13.11	15.56	13.63	965
7	286TSC	40	88.38	62.69	25.69	13.11	15.56	13.63	1138
8	286TSC	40*	93.94	68.25	25.69	13.11	15.56	13.63	1154

\* For non-overload operation, select the next highest motor HP rating.

Motor dimensions are based on Goulds Water Technology's choice motors. Other manufacturer's motor may have different dimensions.