



Submittal Data Information

KS Series Vertical Split Coupled Pumps

301-1710

EFFECTIVE: MAY 31, 2017

SUPERSEDES: FEBRUARY 8, 2010

1160 RPM MODEL 8016

JOB _____ ENGINEER _____

CONTRACTOR _____ REP. _____

ITEM NO.	MODEL NO.	IMPELLER DIA.	G.P.M.	HEAD/FT.	H.P.	ELEC. CHAR.

WEIGHT _____ PUMP/MOTOR _____

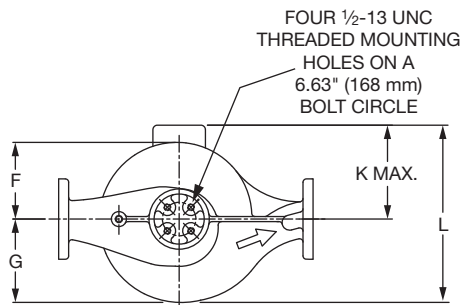
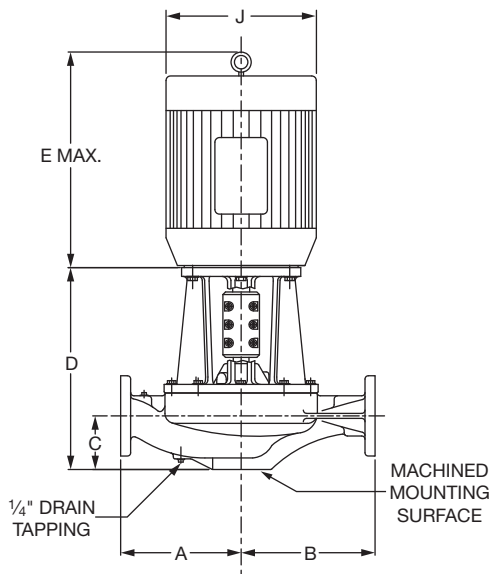

PUMP WITH OPTIONAL SUPPORT STAND

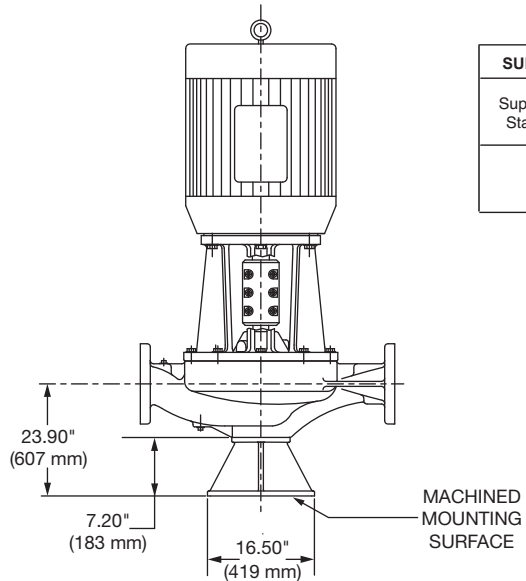

SUPPORT STAND OPTION	
Support Stand	Ductile Iron ASTM A536-84 Grade 65-45-12
<input type="checkbox"/> YES	<input type="checkbox"/> NO

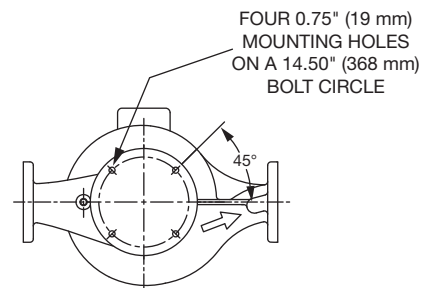

DIMENSIONS

*A & B Dimensions apply for all pump sizes.

Model No.	Conn.	Motor Frame	HP 1160 RPM	Flange Size ASA	A*	B*	C	D	E MAX	F	G	H	J DIA MAX	K MAX	L
8016	8 x 8 (203 x 203)	324CZ	25	8 (203)	26.13 (664) if ANSI Class 125	24.00 (610) if ANSI Class 125	16.70 (424)	33.95 (862)	31.07 (789)	12.28 (312)	15.56 (395)	0.25 (6)	17.35 (441)	14.12 (359)	29.68 (754)
		326CZ	30						32.53 (826)				17.35 (441)	14.12 (359)	29.68 (754)
		364CZ	40						34.40 (874)				19.25 (489)	14.97 (380)	30.53 (775)
		365CZ	50		35.29 (896)	19.25 (489)			14.97 (380)				30.53 (775)		
		404CZ	60		38.53 (979)	21.42 (544)			18.65 (474)				34.20 (869)		
		405CZ	75		38.53 (979)	21.42 (544)			18.65 (474)				34.20 (869)		

English dimensions are in inches. Metric dimensions are in millimeters. Metric data is presented in ().
Do not use for construction purposes unless certified.

MATERIALS OF CONSTRUCTION

	BRONZE FITTED		
	STANDARD PUMP CONSTRUCTION		OPTIONAL 125# or 250#
	125# Flange	250# Flange	
Casing	Cast Iron ASTM A48/ A48M-03 Class 30A	Ductile Iron ASTM A536-84 Grade 65-45-12	N/A
Impeller	Bronze ASTM B584 ALLOY C83600 or C84400	Bronze ASTM B584 ALLOY C83600 or C84400	N/A
Wear Ring	N/A	N/A	Bronze ASTM B584-98A C92200
Shaft	Stainless Steel TYPE 416"™" or 410"™" ASTM A582	Stainless Steel TYPE 416"™" or 410"™" ASTM A582	N/A
Coupling	Aluminum Alloy 6061-T6	Aluminum Alloy 6061-T6	N/A
Mechanical Seal	Ceramic/EPT	Ceramic/EPT	Tungsten Carbide/EPT or Silicon-Carbide/EPT
Seal Flush Line	Copper & Brass C3600	Copper & Brass C3600	N/A

N/A = Not available

Revised: 05/31/2017

OPERATING SPECIFICATIONS

	Standard		Optional
Flange	ANSI Class 125	ANSI Class 250	
Pressure	175 PSIG* (1210 KPA)	300 PSIG** (2070 KPA)	CF
Temperature	250°F (120°C)	250°F (120°C)	CF

Motors: All NEMA Standard ODP Frame (CZ Shaft)

* In accordance with ANSI Standard B16.1 Class 125

** In accordance with ANSI Standard B16.1 Class 250 Dim.

MAXIMUM ASSEMBLY WEIGHT

Motor Frame	Weight without Optional Stand Lbs (Kg)	Weight with Optional Stand Lbs (Kg)
324CZ - 326CZ	2182 (990)	2282 (1035)
364CZ - 365CZ	2382 (1080)	2482 (1126)
404CZ - 405CZ	2703 (1226)	2803 (1271)

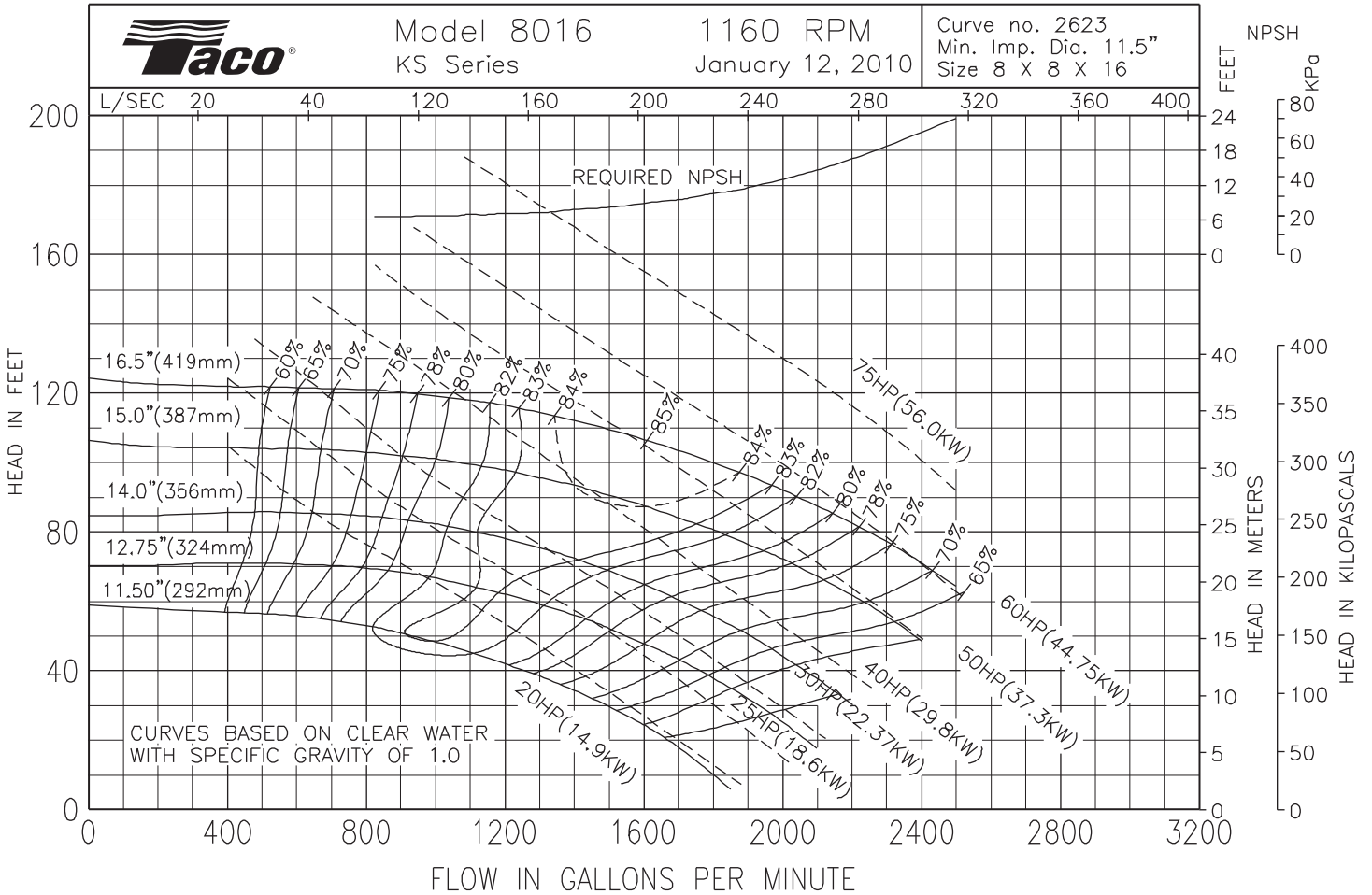

Comments:



Taco, Inc., 1160 Cranston Street, Cranston, RI 02920 | Tel: (401) 942-8000 | FAX: (401) 942-2360

Taco (Canada), Ltd., 8450 Lawson Road, Suite #3, Milton, Ontario L9T 0J8 | Tel: (905) 564-9422 | FAX: (905) 564-9436

Visit our web site: www.TacoComfort.com | Printed in USA | ©2017 Taco, Inc.





Submittal Data Information

KS Series Vertical Split Coupled Pumps

301-1711

EFFECTIVE: MAY 31, 2017

SUPERSEDES: FEBRUARY 8, 2010

1760 RPM MODEL 8016

JOB _____ ENGINEER _____

CONTRACTOR _____ REP. _____

ITEM NO.	MODEL NO.	IMPELLER DIA.	G.P.M.	HEAD/FT.	H.P.	ELEC. CHAR.

WEIGHT _____ PUMP/MOTOR _____

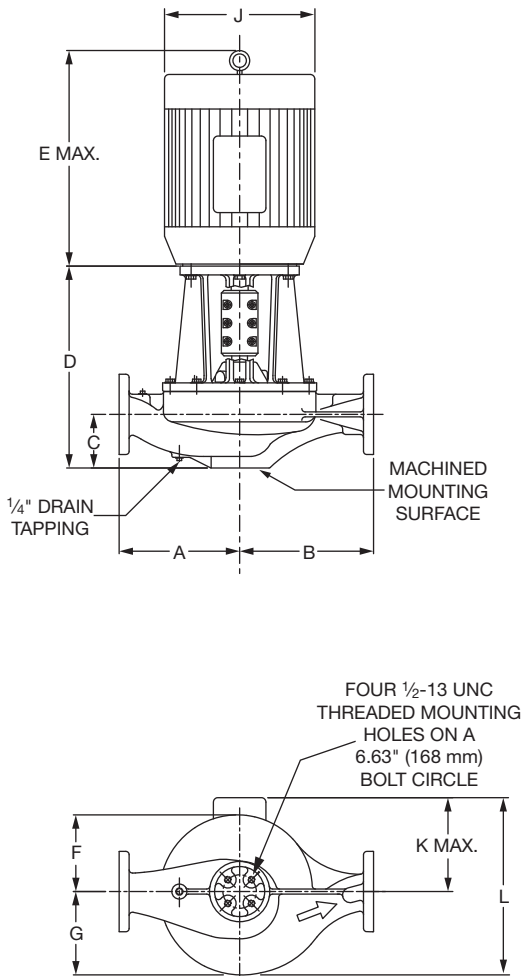

PUMP WITH OPTIONAL SUPPORT STAND

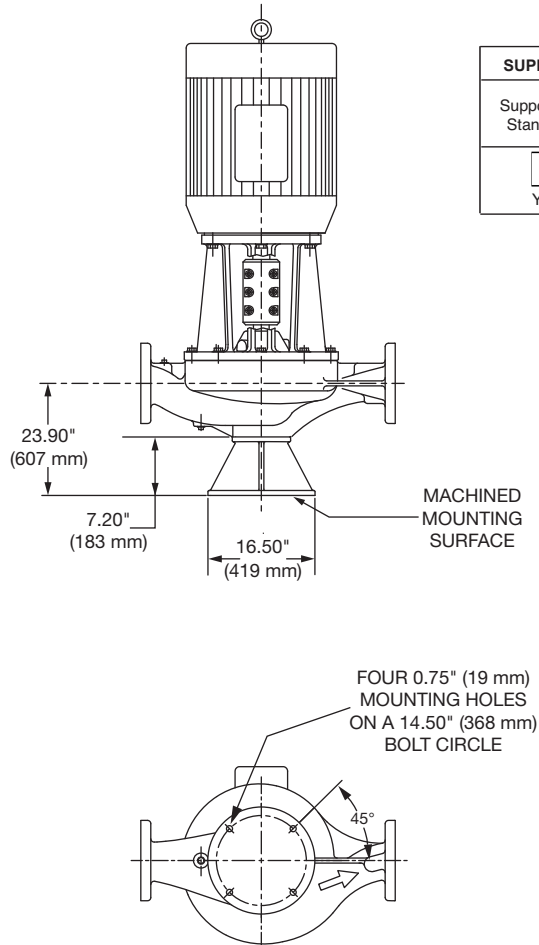

SUPPORT STAND OPTION	
Support Stand	Ductile Iron ASTM A536-84 Grade 65-45-12
<input type="checkbox"/> YES	<input type="checkbox"/> NO

DIMENSIONS

*A & B Dimensions apply for all pump sizes.

Model No.	Conn.	Motor Frame	HP 1760 RPM	Flange Size ASA	A*	B*	C	D	E MAX	F	G	H	J DIA MAX	K MAX	L
8016	8 x 8 (203 x 203)	365CZ	75	8 (203)	26.13 (664) if ANSI Class 125	24.00 (610) if ANSI Class 125	16.70 (424)	33.95 (862)	35.29 (896)	12.28 (312)	15.56 (395)	0.25 (6)	19.25 (489)	14.97 (380)	30.53 (775)
		405CZ	100						38.53 (979)				21.42 (544)	18.65 (474)	34.20 (869)
		444HP	125						43.49 (1104)				24.56 (624)	20.75 (527)	36.31 (922)
		445HP	150		43.49 (1104)	24.56 (624)			20.75 (527)				36.31 (922)		
		447HP	200		52.50 (1333)	24.56 (624)			21.71 (551)				37.27 (947)		
		449HP	250		52.50 (1333)	24.56 (624)			21.71 (551)				37.27 (947)		

English dimensions are in inches. Metric dimensions are in millimeters. Metric data is presented in ().
Do not use for construction purposes unless certified.

MATERIALS OF CONSTRUCTION

	BRONZE FITTED		
	STANDARD PUMP CONSTRUCTION		OPTIONAL
	125# Flange	250# Flange	125# or 250#
Casing	Cast Iron ASTM A48/ A48M-03 Class 30A	Ductile Iron ASTM A536-84 Grade 65-45-12	N/A
Impeller	Bronze ASTM B584 ALLOY C83600 or C84400	Bronze ASTM B584 ALLOY C83600 or C84400	N/A
Wear Ring	N/A	N/A	Bronze ASTM B584-98A C92200
Shaft	Stainless Steel TYPE 416™™ or 410™™ ASTM A582	Stainless Steel TYPE 416™™ or 410™™ ASTM A582	N/A
Coupling	Aluminum Alloy 6061-T6	Aluminum Alloy 6061-T6	N/A
Mechanical Seal	Ceramic/EPT	Ceramic/EPT	Tungsten Carbide/EPT or Silicon-Carbide/EPT
Seal Flush Line	Copper & Brass C3600	Copper & Brass C3600	N/A

N/A = Not available

Revised: 05/31/2017

OPERATING SPECIFICATIONS

	Standard		Optional
Flange	ANSI Class 125	ANSI Class 250	
Pressure	175 PSIG* (1210 KPA)	300 PSIG** (2070 KPA)	CF
Temperature	250°F (120°C)	250°F (120°C)	CF

Motors: All NEMA Standard ODP Frame (CZ Shaft)
 * In accordance with ANSI Standard B16.1 Class 125
 ** In accordance with ANSI Standard B16.1 Class 250 Dim.

MAXIMUM ASSEMBLY WEIGHT

Motor Frame	Weight without Optional Stand Lbs (Kg)	Weight with Optional Stand Lbs (Kg)
364CZ - 365CZ	2442 (1108)	2542 (1153)
404CZ - 405CZ	2779 (1261)	2879 (1306)
444HP - 445HP	3272 (1484)	3372 (1530)
447HP - 449HP	4184 (1898)	4284 (1943)

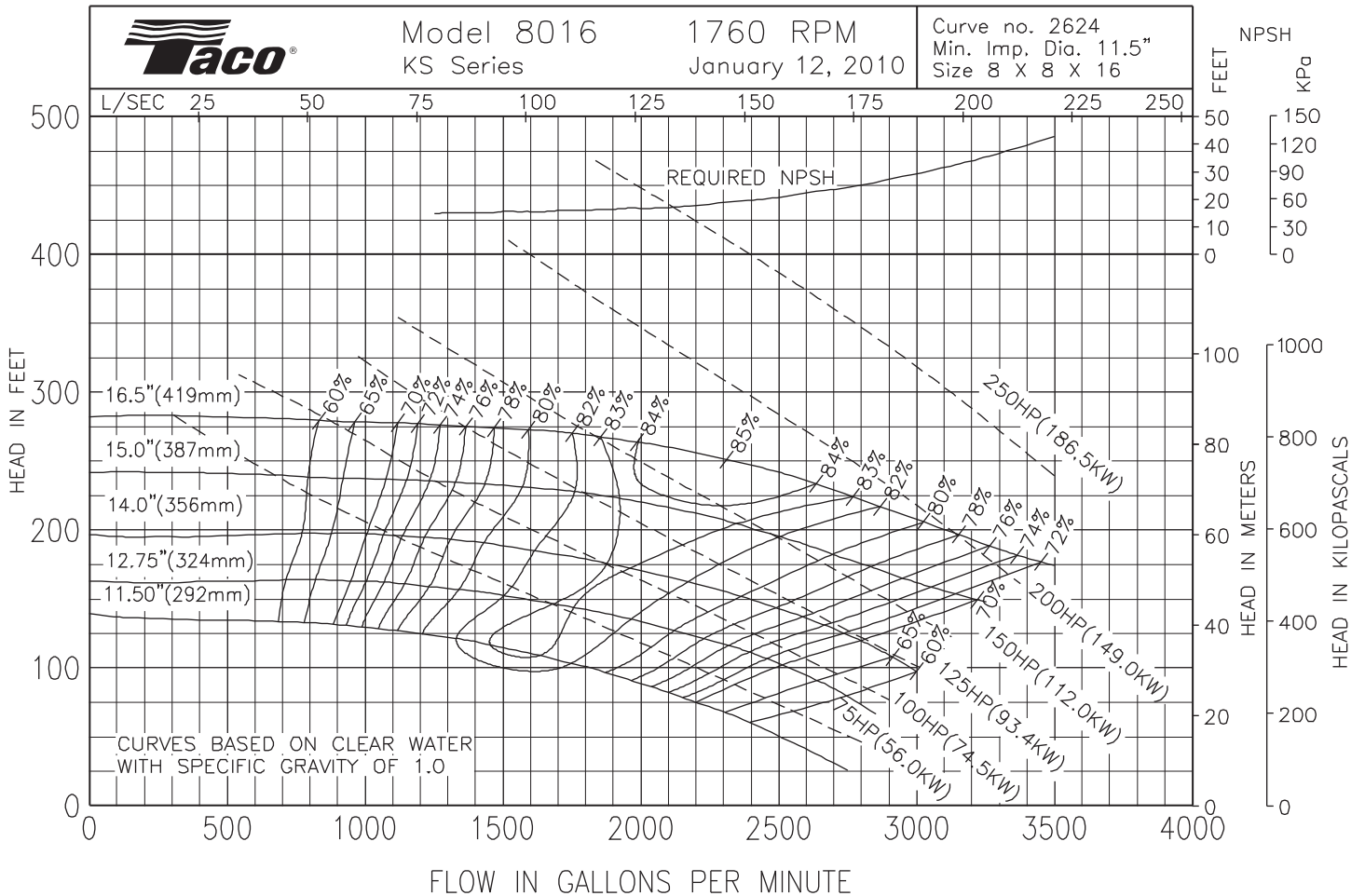

Comments:



Submittal Data Information

KS Series Vertical Split Coupled Pumps

301-1720 I

EFFECTIVE: MAY 31, 2017

SUPERSEDES: FEBRUARY 8, 2010

1450 RPM MODEL 8016

JOB _____ ENGINEER _____

CONTRACTOR _____ REP. _____

ITEM NO.	MODEL NO.	IMPELLER DIA.	G.P.M.	HEAD/FT.	H.P.	ELEC. CHAR.

WEIGHT _____ PUMP/MOTOR _____

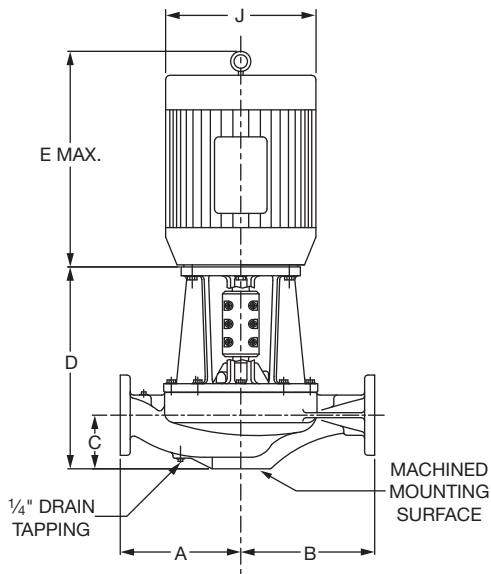

PUMP WITH OPTIONAL SUPPORT STAND

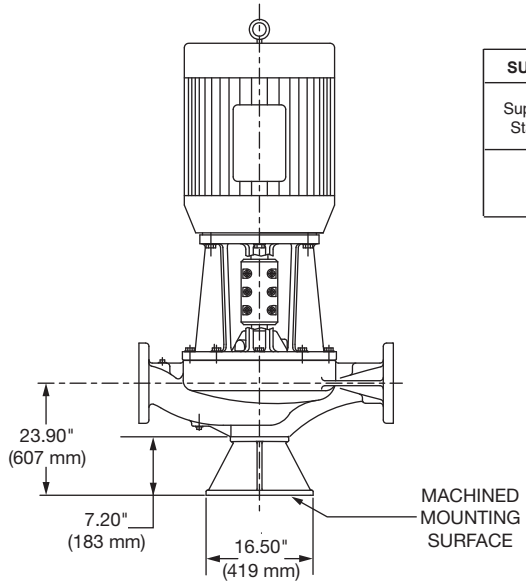

SUPPORT STAND OPTION	
Support Stand	Ductile Iron ASTM A536-84 Grade 65-45-12
<input type="checkbox"/>	<input type="checkbox"/>
YES	NO

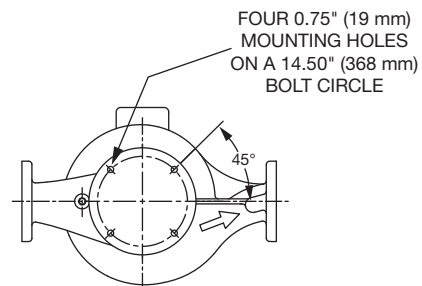
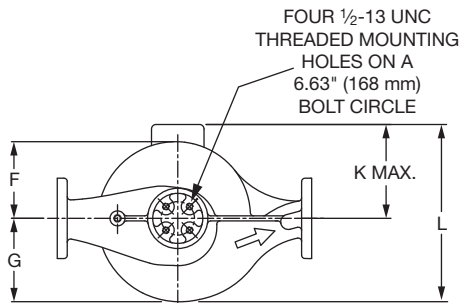

DIMENSIONS

*A & B Dimensions apply for all pump sizes.

Model No.	Conn.	Motor Frame	HP 1450 RPM	Flange Size ASA	A*	B*	C	D	E MAX	F	G	H	J DIA MAX	K MAX	L
8016	8 x 8 (203 x 203)	324CZ	40	8 (203)	26.13 (664) if ANSI Class 125	24.00 (610) if ANSI Class 125	16.70 (424)	33.95 (862)	31.07 (789)	12.28 (312)	15.56 (395)	0.25 (6)	17.35 (441)	14.12 (359)	29.68 (754)
		326CZ	50						32.53 (826)				17.35 (441)	14.12 (359)	29.68 (754)
		364CZ	60						34.40 (874)				19.25 (489)	14.97 (380)	30.53 (775)
		365CZ	75		35.29 (896)	19.25 (489)			14.97 (380)				30.53 (775)		
		405CZ	100		38.53 (979)	21.42 (544)			18.65 (474)				34.20 (869)		
		444HP	125		43.49 (1104)	24.56 (624)			20.75 (527)				36.31 (922)		

English dimensions are in inches. Metric dimensions are in millimeters. Metric data is presented in ().
Do not use for construction purposes unless certified.

MATERIALS OF CONSTRUCTION

	BRONZE FITTED		
	STANDARD PUMP CONSTRUCTION		OPTIONAL
	125# Flange	250# Flange	125# or 250#
Casing	Cast Iron ASTM A48/ A48M-03 Class 30A	Ductile Iron ASTM A536-84 Grade 65-45-12	N/A
Impeller	Bronze ASTM B584 ALLOY C83600 or C84400	Bronze ASTM B584 ALLOY C83600 or C84400	N/A
Wear Ring	N/A	N/A	Bronze ASTM B584-98A C92200
Shaft	Stainless Steel TYPE 416"™ or 410"™ ASTM A582	Stainless Steel TYPE 416"™ or 410"™ ASTM A582	N/A
Coupling	Aluminum Alloy 6061-T6	Aluminum Alloy 6061-T6	N/A
Mechanical Seal	Ceramic/EPT	Ceramic/EPT	Tungsten Carbide/EPT or Silicon Carbide/EPT
Seal Flush Line	Copper & Brass C3600	Copper & Brass C3600	N/A

N/A = Not available

Revised: 05/31/2017

OPERATING SPECIFICATIONS

	Standard		Optional
Flange	ANSI Class 125	ANSI Class 250	
Pressure	175 PSIG* (1210 KPA)	300 PSIG** (2070 KPA)	CF
Temperature	250°F (120°C)	250°F (120°C)	CF

Motors: All NEMA Standard ODP Frame (CZ Shaft)
 * In accordance with ANSI Standard B16.1 Class 125
 ** In accordance with ANSI Standard B16.1 Class 250 Dim.

MAXIMUM ASSEMBLY WEIGHT

Motor Frame	Weight without Optional Stand Lbs (Kg)	Weight with Optional Stand Lbs (Kg)
324CZ - 326CZ	2565 (1163)	2665 (1209)
364CZ - 365CZ	2770 (1256)	2870 (1302)
404CZ - 405CZ	3076 (1395)	3176 (1441)
444HP - 445HP	3618 (1641)	3718 (1686)

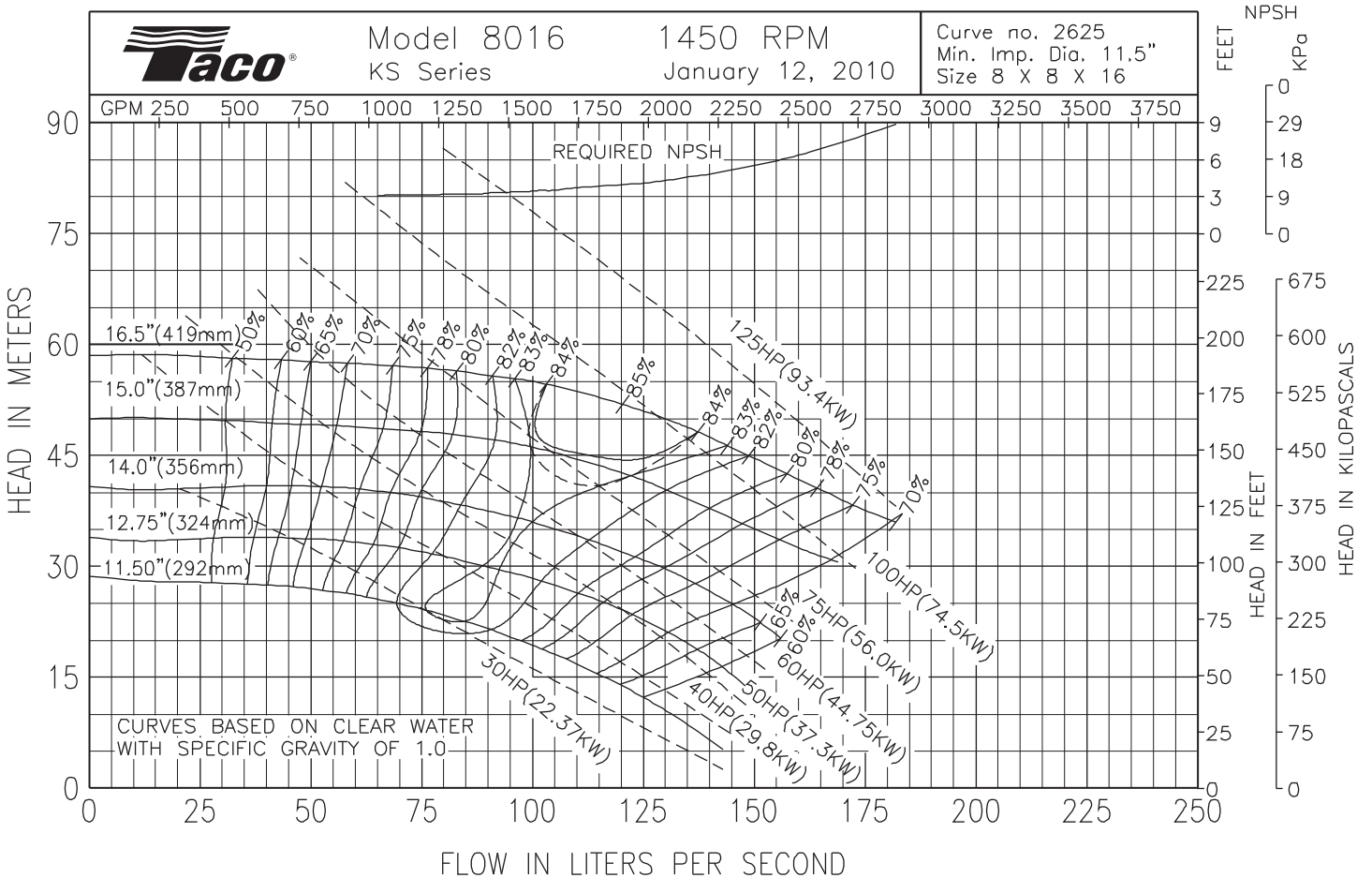

Comments:



Taco, Inc., 1160 Cranston Street, Cranston, RI 02920 | Tel: (401) 942-8000 | FAX: (401) 942-2360

Taco (Canada), Ltd., 8450 Lawson Road, Suite #3, Milton, Ontario L9T 0J8 | Tel: (905) 564-9422 | FAX: (905) 564-9436

Visit our web site: www.TacoComfort.com | Printed in USA | ©2017 Taco, Inc.

