



Submittal Data Information

KS Series Vertical Split Coupled Pumps

301-1191

EFFECTIVE: MAY 31, 2017

SUPERSEDES: JUNE 25, 2016

1160 RPM MODEL 5075

JOB _____ ENGINEER _____

CONTRACTOR _____ REP. _____

ITEM NO.	MODEL NO.	IMPELLER DIA.	G.P.M.	HEAD/FT.	H.P.	ELEC. CHAR.
----------	-----------	---------------	--------	----------	------	-------------

WEIGHT _____ PUMP/MOTOR _____

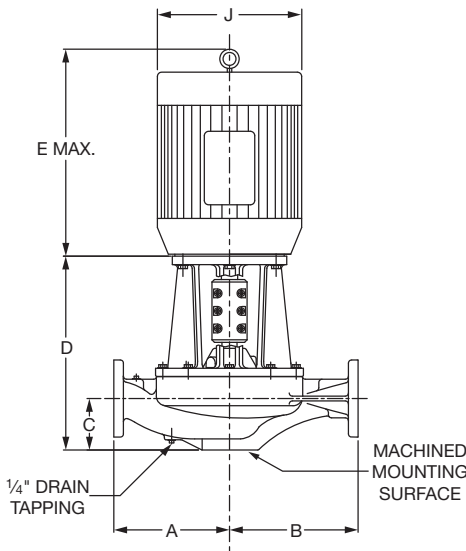

FOUR 3/8 -16 UNC
THREADED MOUNTING
HOLES ON A
6.00" (152 mm)
BOLT CIRCLE

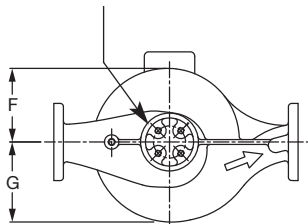

PUMP WITH OPTIONAL SUPPORT STAND

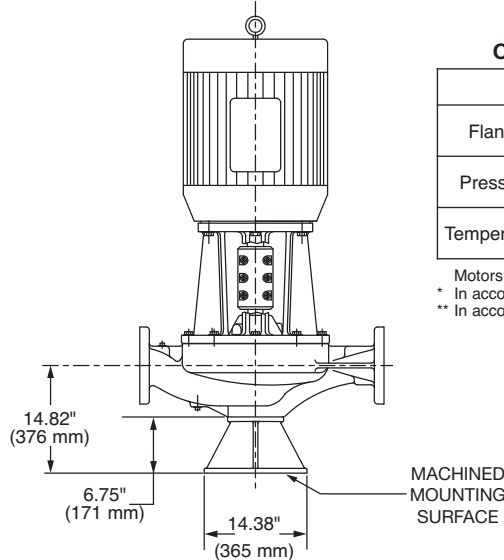

FOUR 0.75" (19 mm)
MOUNTING HOLES
ON A 11.88" (302 mm)
BOLT CIRCLE

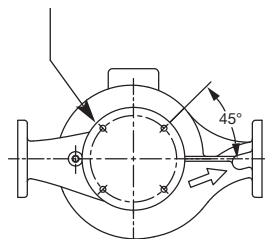

OPERATING SPECIFICATIONS

	Standard		Optional
Flange	ANSI Class 125	ANSI Class 250	
Pressure	175 PSIG* (1210 KPA)	300 PSIG** (2070 KPA)	CF
Temperature	250°F (120°C)	250°F (120°C)	CF

Motors: All NEMA Standard ODP Frame (CZ Shaft)
* In accordance with ANSI Standard B16.1 Class 125
** In accordance with ANSI Standard B16.1 Class 250 Dim.

SUPPORT STAND OPTION	
Support Stand	Ductile Iron ASTM A536-84 Grade 65-45-12
<input type="checkbox"/>	<input type="checkbox"/>
YES	NO

MAXIMUM ASSEMBLY WEIGHT

Motor Frame	Weight without Optional Stand Lbs (Kg)	Weight with Optional Stand Lbs (Kg)
143CZ - 145CZ	317 (144)	383 (174)
182CZ - 184CZ	356 (161)	422 (191)
213CZ - 215CZ	397 (180)	463 (210)

DIMENSIONS

*A & B Dimensions apply for all pump sizes.

Model No.	Conn.	Motor Frame	HP 1160 RPM	Flange Size ASA	A*	B*	C	D	E MAX	F	G	H	J DIA
5075	5 x 5 (127 x 127)	145CZ	1	5 (127)	14.00 (355) if ANSI Class 125	11.00 (279) if ANSI Class 125	8.07 (205)	19.65 (499)	14.05 (357)	6.31 (160)	8.10 (205)	0.25 (6)	7.05 (179)
		182CZ	1.5					19.65 (499)	15.64 (397)				8.49 (216)
		184CZ	2					19.65 (499)	16.68 (424)				8.49 (216)
		213CZ	3					19.65 (499)	19.13 (486)				10.18 (259)
					14.44 (366) if ANSI Class 250	11.44 (291) if ANSI Class 250							

English dimensions are in inches. Metric dimensions are in millimeters. Metric data is presented in ().
Do not use for construction purposes unless certified.

MATERIALS OF CONSTRUCTION

	BRONZE FITTED		
	STANDARD PUMP CONSTRUCTION		OPTIONAL
	125# Flange	250# Flange	125# or 250#
Casing	Cast Iron ASTM A48/ A48M-03 Class 30A	Ductile Iron ASTM A536-84 Grade 65-45-12	N/A
Impeller	Bronze ASTM B584 ALLOY C83600 or C84400	Bronze ASTM B584 ALLOY C83600 or C84400	N/A
Wear Ring	N/A	N/A	Bronze ASTM B584-98A C92200
Shaft	Stainless Steel TYPE 416"™" or 410"™" ASTM A582	Stainless Steel TYPE 416"™" or 410"™" ASTM A582	N/A
Coupling	Aluminum Alloy 6061-T6	Aluminum Alloy 6061-T6	N/A
Mechanical Seal	Ceramic/EPT	Ceramic/EPT	Tungsten Carbide/EPT or Silicon- Carbide/EPT
Seal Flush Line	Copper & Brass C3600	Copper & Brass C3600	N/A

N/A = Not available

Revised: 05/31/2017

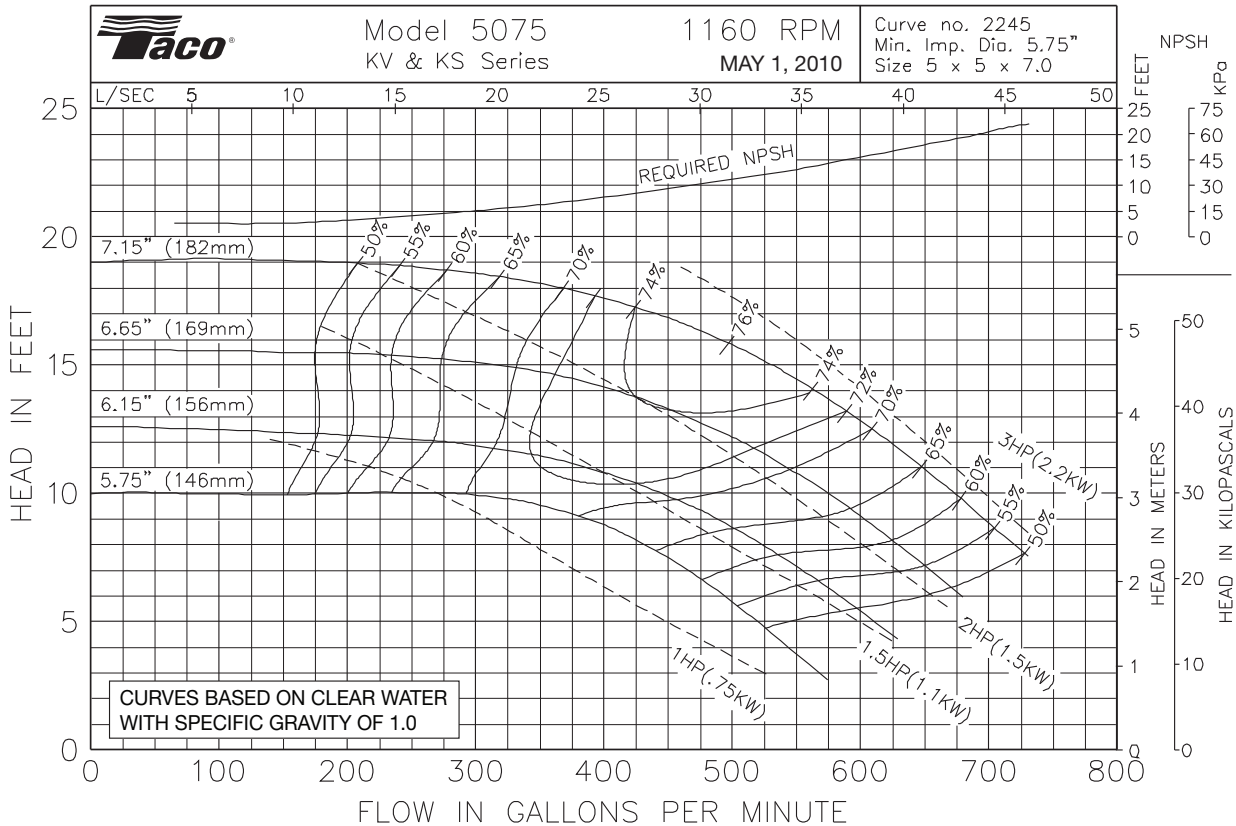

Comments: _____



Taco, Inc., 1160 Cranston Street, Cranston, RI 02920 | Tel: (401) 942-8000 | FAX: (401) 942-2360

Taco (Canada), Ltd., 8450 Lawson Road, Suite #3, Milton, Ontario L9T 0J8 | Tel: (905) 564-9422 | FAX: (905) 564-9436

Visit our web site: www.TacoComfort.com | Printed in USA | ©2017 Taco, Inc.





Submittal Data Information

KS Series Vertical Split Coupled Pumps

301-1192

EFFECTIVE: MAY 31, 2017

SUPERSEDES: JUNE 25, 2016

1760 RPM MODEL 5075

JOB _____ ENGINEER _____

CONTRACTOR _____ REP. _____

ITEM NO.	MODEL NO.	IMPELLER DIA.	G.P.M.	HEAD/FT.	H.P.	ELEC. CHAR.
----------	-----------	---------------	--------	----------	------	-------------

WEIGHT _____ PUMP/MOTOR _____

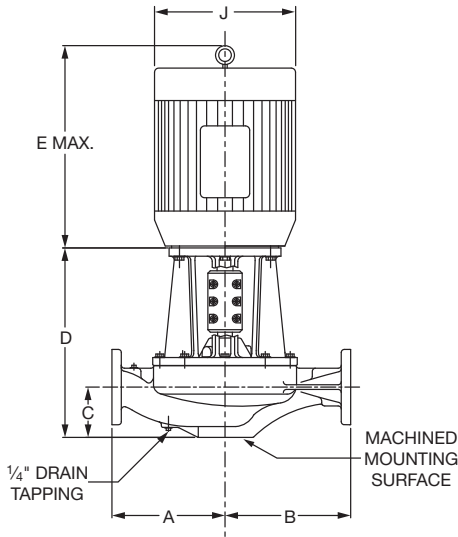

FOUR 3/8 -16 UNC
THREADED MOUNTING
HOLES ON A
6.00" (152 mm)
BOLT CIRCLE

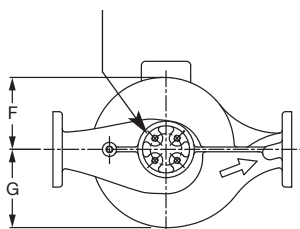

PUMP WITH OPTIONAL SUPPORT STAND

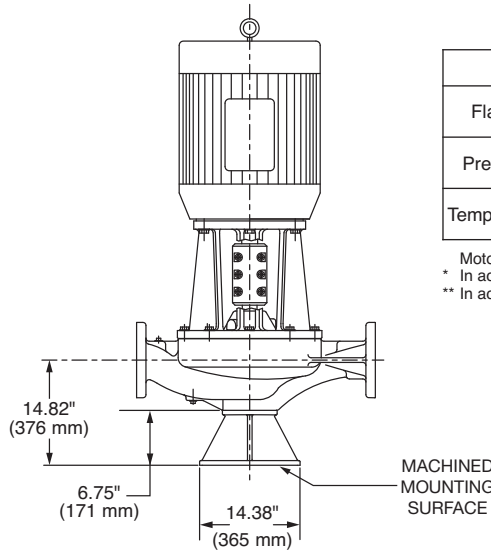

FOUR 0.75" (19 mm)
MOUNTING HOLES
ON A 11.88" (302 mm)
BOLT CIRCLE

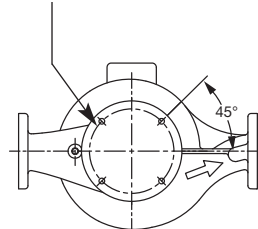

OPERATING SPECIFICATIONS

	Standard		Optional
	ANSI Class 125	ANSI Class 250	
Flange	ANSI Class 125	ANSI Class 250	
Pressure	175 PSIG* (1210 KPA)	300 PSIG** (2070 KPA)	CF
Temperature	250°F (120°C)	250°F (120°C)	CF

Motors: All NEMA Standard ODP Frame (CZ Shaft)
* In accordance with ANSI Standard B16.1 Class 125
** In accordance with ANSI Standard B16.1 Class 250 Dim.

SUPPORT STAND OPTION	
Support Stand	Ductile Iron ASTM A536-84 Grade 65-45-12
<input type="checkbox"/>	<input type="checkbox"/>
YES	NO

MAXIMUM ASSEMBLY WEIGHT

Motor Frame	Weight without Optional Stand Lbs (Kg)	Weight with Optional Stand Lbs (Kg)
182CZ - 184CZ	433 (196)	499 (226)
213CZ - 215CZ	487 (221)	553 (251)

DIMENSIONS

*A & B Dimensions apply for all pump sizes.

Model No.	Conn.	Motor Frame	HP 1760 RPM	Flange Size ASA	A*	B*	C	D	E MAX	F	G	H	J DIA
5075	5 x 5 (127 x 127)	182CZ	3	5 (127)	14.00 (355) if ANSI Class 125	11.00 (279) if ANSI Class 125	8.07 (205)	19.65 (499)	15.64 (397)	6.31 (160)	8.10 (205)	0.25 (6)	8.49 (216)
		184CZ	5					19.65 (499)	16.68 (424)				8.49 (216)
		213CZ	7.5					19.65 (499)	19.13 (486)				10.18 (259)
		215CZ	10					19.65 (499)	20.63 (524)				10.18 (259)
					14.44 (366) if ANSI Class 250	11.44 (291) if ANSI Class 250							

English dimensions are in inches. Metric dimensions are in millimeters. Metric data is presented in ().
Do not use for construction purposes unless certified.

MATERIALS OF CONSTRUCTION

	BRONZE FITTED		
	STANDARD PUMP CONSTRUCTION		OPTIONAL
	125# Flange	250# Flange	125# or 250#
Casing	Cast Iron ASTM A48/ A48M-03 Class 30A	Ductile Iron ASTM A536-84 Grade 65-45-12	N/A
Impeller	Bronze ASTM B584 ALLOY C83600 or C84400	Bronze ASTM B584 ALLOY C83600 or C84400	N/A
Wear Ring	N/A	N/A	Bronze ASTM B584-98A C92200
Shaft	Stainless Steel TYPE 416"™" or 410"™" ASTM A582	Stainless Steel TYPE 416"™" or 410"™" ASTM A582	N/A
Coupling	Aluminum Alloy 6061-T6	Aluminum Alloy 6061-T6	N/A
Mechanical Seal	Ceramic/EPT	Ceramic/EPT	Tungsten Carbide/EPT or Silicon- Carbide/EPT
Seal Flush Line	Copper & Brass C3600	Copper & Brass C3600	N/A

N/A = Not available

Revised: 05/31/2017

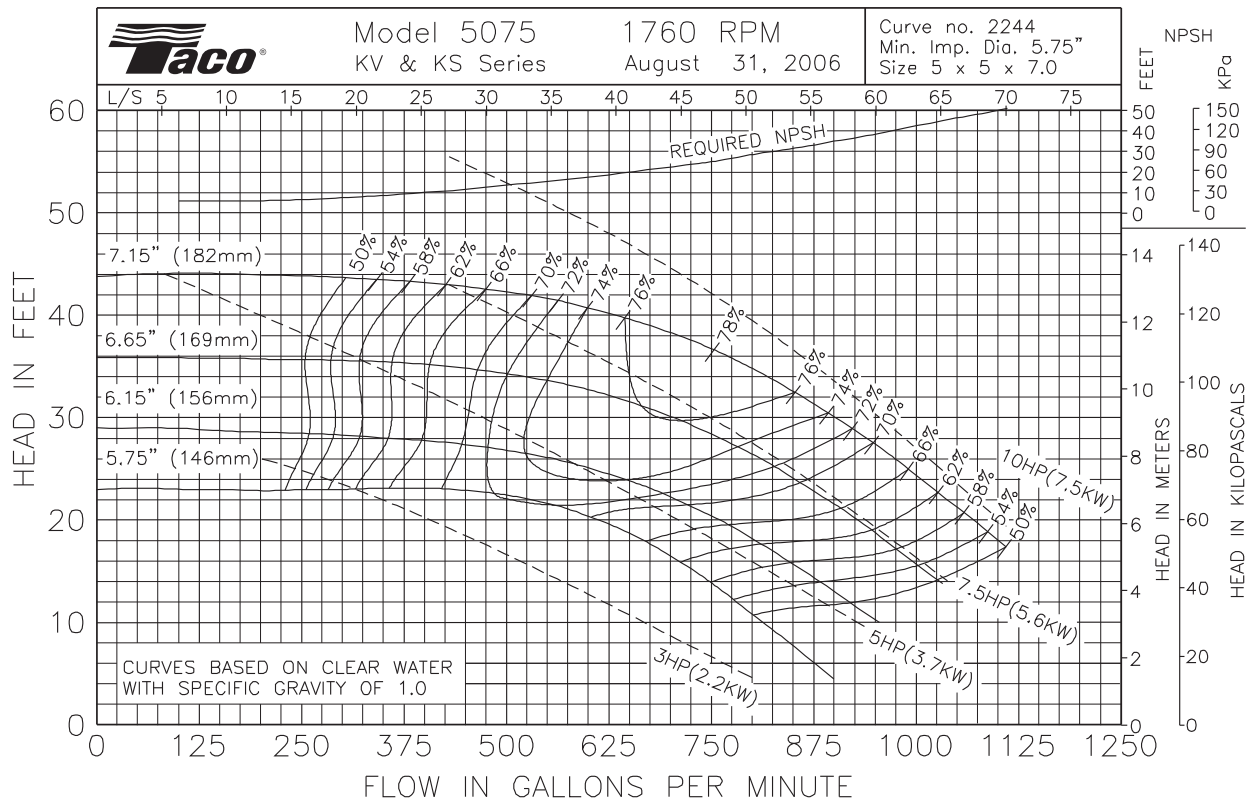

Comments:



Submittal Data Information

KS Series Vertical Split Coupled Pumps

301-1193

EFFECTIVE: MAY 31, 2017

SUPERSEDES: JUNE 25, 2016

3500 RPM MODEL 5075

JOB _____ ENGINEER _____

CONTRACTOR _____ REP. _____

ITEM NO.	MODEL NO.	IMPELLER DIA.	G.P.M.	HEAD/FT.	H.P.	ELEC. CHAR.
----------	-----------	---------------	--------	----------	------	-------------

WEIGHT _____ PUMP/MOTOR _____

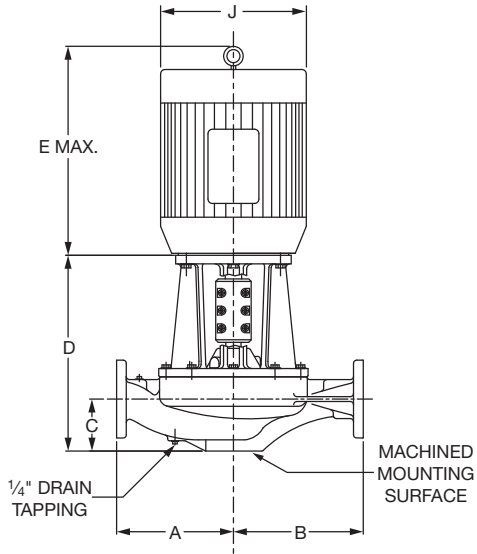

FOUR 3/8" -16 UNC
THREADED MOUNTING
HOLES ON A
6.00" (152 mm)
BOLT CIRCLE

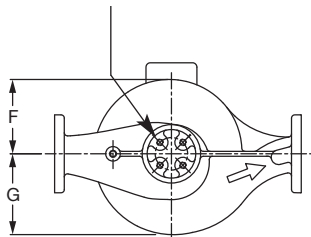

PUMP WITH OPTIONAL SUPPORT STAND

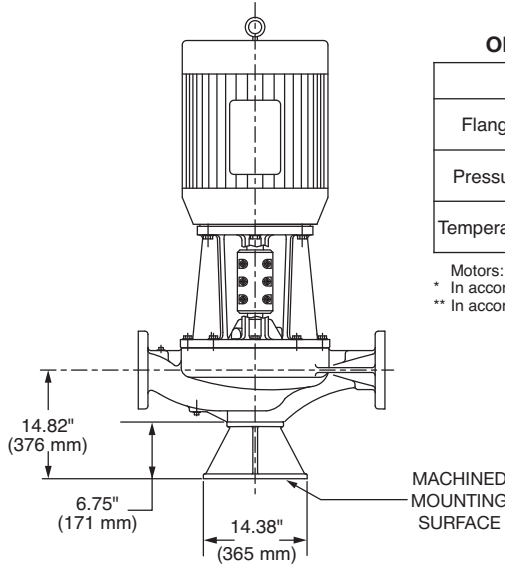

FOUR 0.75" (19 mm)
MOUNTING HOLES
ON A 11.88" (302 mm)
BOLT CIRCLE

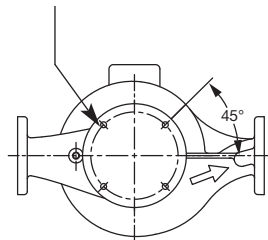

OPERATING SPECIFICATIONS

	Standard		Optional
Flange	ANSI Class 125	ANSI Class 250	
Pressure	175 PSIG* (1210 KPA)	300 PSIG** (2070 KPA)	CF
Temperature	250°F (120°C)	250°F (120°C)	CF

Motors: All NEMA Standard ODP Frame (CZ Shaft)
* In accordance with ANSI Standard B16.1 Class 125
** In accordance with ANSI Standard B16.1 Class 250 Dim.

SUPPORT STAND OPTION	
Support Stand	Ductile Iron ASTM A536-84 Grade 65-45-12
<input type="checkbox"/>	<input type="checkbox"/>
YES	NO

MAXIMUM ASSEMBLY WEIGHT

Motor Frame	Weight without Optional Stand Lbs (Kg)	Weight with Optional Stand Lbs (Kg)
284CZ - 286CZ	778 (353)	844 (383)
324CZ - 326CZ	1082 (491)	1148 (521)

DIMENSIONS

*A & B Dimensions apply for all pump sizes.

Model No.	Conn.	Motor Frame	HP 3500 RPM	Flange Size ASA	A*	B*	C	D	E MAX	F	G	H	J DIA
5075	5 x 5 (127 x 127)	284CZ	30	5 (127)	14.00 (355) if ANSI Class 125	11.00 (279) if ANSI Class 125	8.07 (205)	22.89 (581)	27.94 (710)	6.31 (160)	8.10 (205)	0.25 (6)	14.63 (372)
		286CZ	40					22.89 (581)	29.14 (740)				14.63 (372)
		324CZ	50					24.64 (625)	31.07 (789)				16.50 (419)
		326CZ	60**		24.64 (625)	32.57 (827)		16.50 (419)					
				14.44 (366) if ANSI Class 250	11.44 (291) if ANSI Class 250								

English dimensions are in inches. Metric dimensions are in millimeters. Metric data is presented in ().

** Not available in TEFC. Do not use for construction purposes unless certified.

MATERIALS OF CONSTRUCTION

	BRONZE FITTED		
	STANDARD PUMP CONSTRUCTION		OPTIONAL
	125# Flange	250# Flange	125# or 250#
Casing	Cast Iron ASTM A48/ A48M-03 Class 30A	Ductile Iron ASTM A536-84 Grade 65-45-12	N/A
Impeller	Bronze ASTM B584 ALLOY C83600 or C84400	Bronze ASTM B584 ALLOY C83600 or C84400	N/A
Wear Ring	N/A	N/A	Bronze ASTM B584-98A C92200
Shaft	Stainless Steel TYPE 416" T" or 410" T" ASTM A582	Stainless Steel TYPE 416" T" or 410" T" ASTM A582	N/A
Coupling	Aluminum Alloy 6061-T6	Aluminum Alloy 6061-T6	N/A
Mechanical Seal	Ceramic/EPT	Ceramic/EPT	Tungsten Carbide/EPT or Silicon Carbide/EPT
Seal Flush Line	Copper & Brass C3600	Copper & Brass C3600	N/A

N/A = Not available

Revised: 05/31/2017

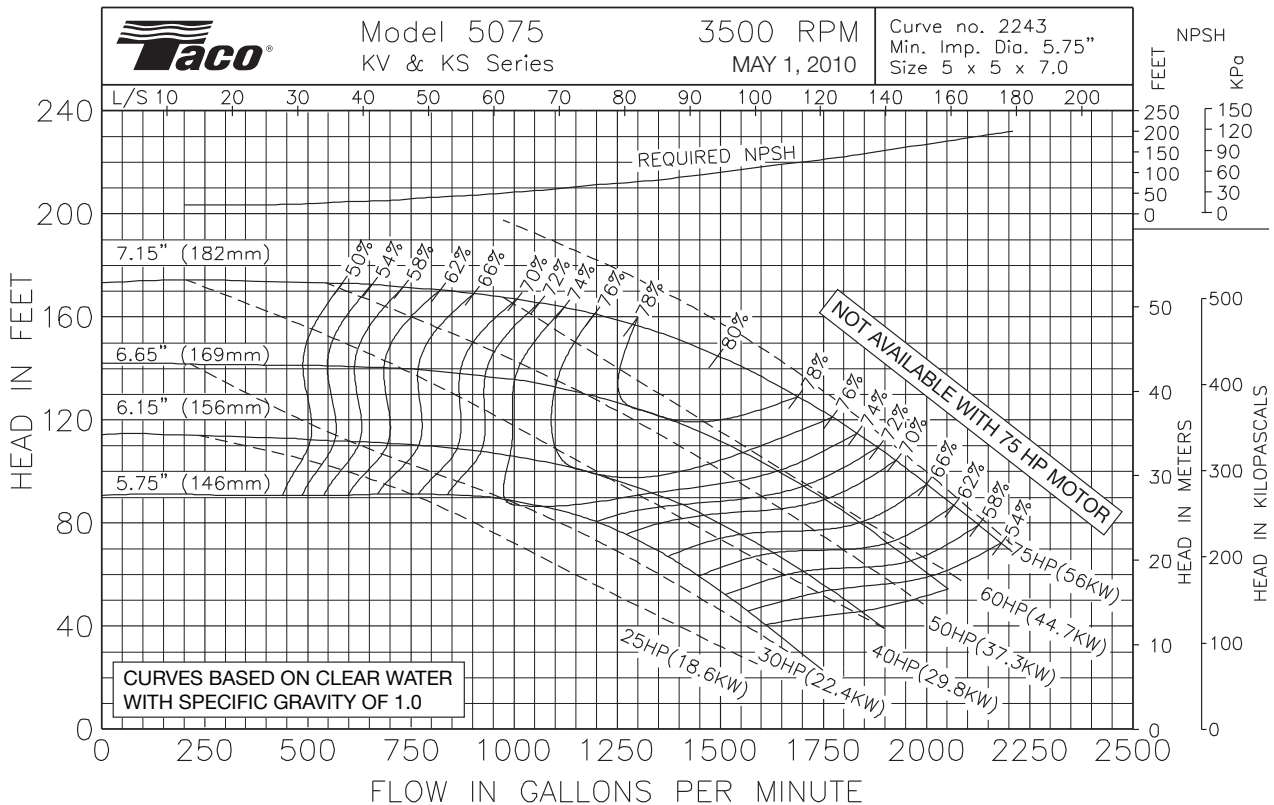

Comments: _____



Submittal Data Information

KS Series Vertical Split Coupled Pumps (50 Hz)

301-1225 I

EFFECTIVE: MAY 31, 2017

SUPERSEDES: JANUARY 8, 2010

1450 RPM MODEL 5075

JOB _____ ENGINEER _____

CONTRACTOR _____ REP. _____

ITEM NO.	MODEL NO.	IMPELLER DIA.	G.P.M.	HEAD/FT.	H.P.	ELEC. CHAR.

WEIGHT _____ PUMP/MOTOR _____

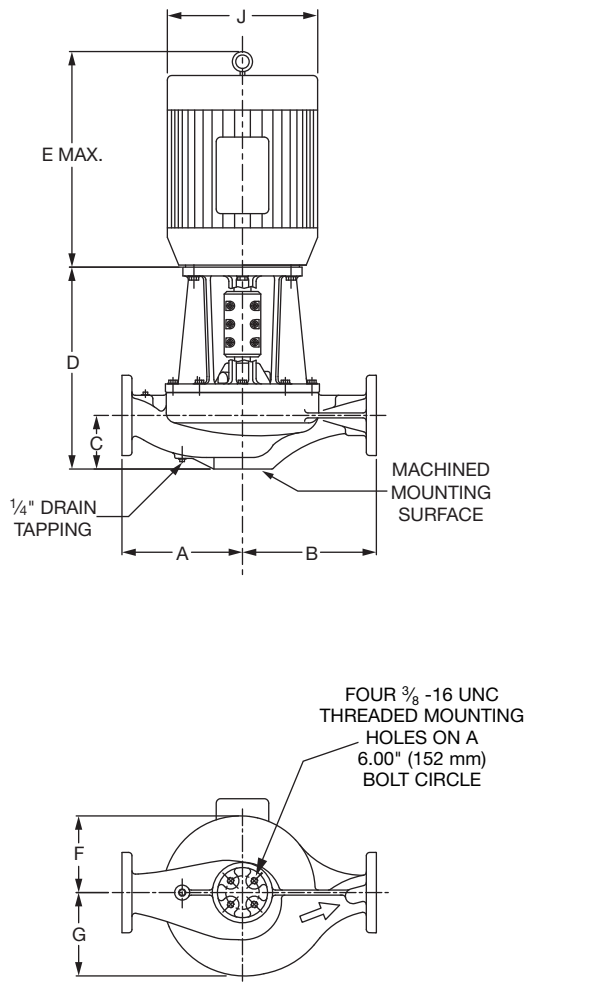

PUMP WITH OPTIONAL SUPPORT STAND

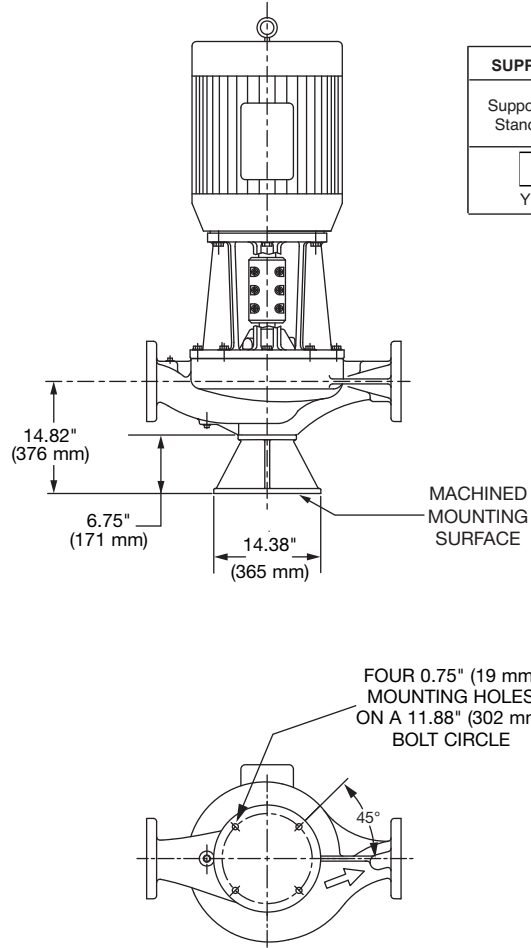

SUPPORT STAND OPTION	
Support Stand	Ductile Iron ASTM A536-84 Grade 65-45-12
<input type="checkbox"/>	<input type="checkbox"/>
YES	NO

DIMENSIONS

*A & B Dimensions apply for all pump sizes.

Model No.	Conn.	Motor Frame	HP 1450 RPM	Flange Size ASA	A*	B*	C	D	E MAX	F	G	H	J DIA
5075	5 x 5 (127 x 127)	145CZ	2	5 (127)	14.00 (355) if ANSI Class 125	11.00 (279) if ANSI Class 125	8.07 (205)	19.65 (499)	14.05 (357)	6.31 (160)	8.10 (205)	0.25 (6)	7.05 (179)
		182CZ	3					19.65 (499)	15.64 (397)				8.49 (216)
		184CZ	5					19.65 (499)	16.68 (424)				8.49 (216)
		213CZ	7.5					19.65 (499)	19.13 (486)				10.18 (259)

English dimensions are in inches. Metric dimensions are in millimeters. Metric data is presented in ().
Do not use for construction purposes unless certified.

MATERIALS OF CONSTRUCTION

	BRONZE FITTED		
	STANDARD PUMP CONSTRUCTION		OPTIONAL 125# or 250#
	125# Flange	250# Flange	
Casing	Cast Iron ASTM A48/ A48M-03 Class 30A	Ductile Iron ASTM A536-84 Grade 65-45-12	N/A
Impeller	Bronze ASTM B584 ALLOY C83600 or C84400	Bronze ASTM B584 ALLOY C83600 or C84400	N/A
Wear Ring	N/A	N/A	Bronze ASTM B584-98A C92200
Shaft	Stainless Steel TYPE 416" T" or 410" T" ASTM A582	Stainless Steel TYPE 416" T" or 410" T" ASTM A582	N/A
Coupling	Aluminum Alloy 6061-T6	Aluminum Alloy 6061-T6	N/A
Mechanical Seal	Ceramic/EPT	Ceramic/EPT	Tungsten Carbide/EPT or Silicon-Carbide/EPT
Seal Flush Line	Copper & Brass C3600	Copper & Brass C3600	N/A

N/A = Not available

Revised: 05/31/2017

OPERATING SPECIFICATIONS

	Standard		Optional
Flange	ANSI Class 125	ANSI Class 250	
Pressure	175 PSIG* (1210 KPA)	300 PSIG** (2070 KPA)	CF
Temperature	250°F (120°C)	250°F (120°C)	CF

Motors: All NEMA Standard ODP Frame (CZ Shaft)
* In accordance with ANSI Standard B16.1 Class 125
** In accordance with ANSI Standard B16.1 Class 250 Dim.

MAXIMUM ASSEMBLY WEIGHT

Motor Frame	Weight without Optional Stand Lbs (Kg)	Weight with Optional Stand Lbs (Kg)
143CZ - 145CZ	437 (198)	503 (228)
182CZ - 184CZ	476 (216)	542 (246)
213CZ - 215CZ	536 (243)	602 (273)

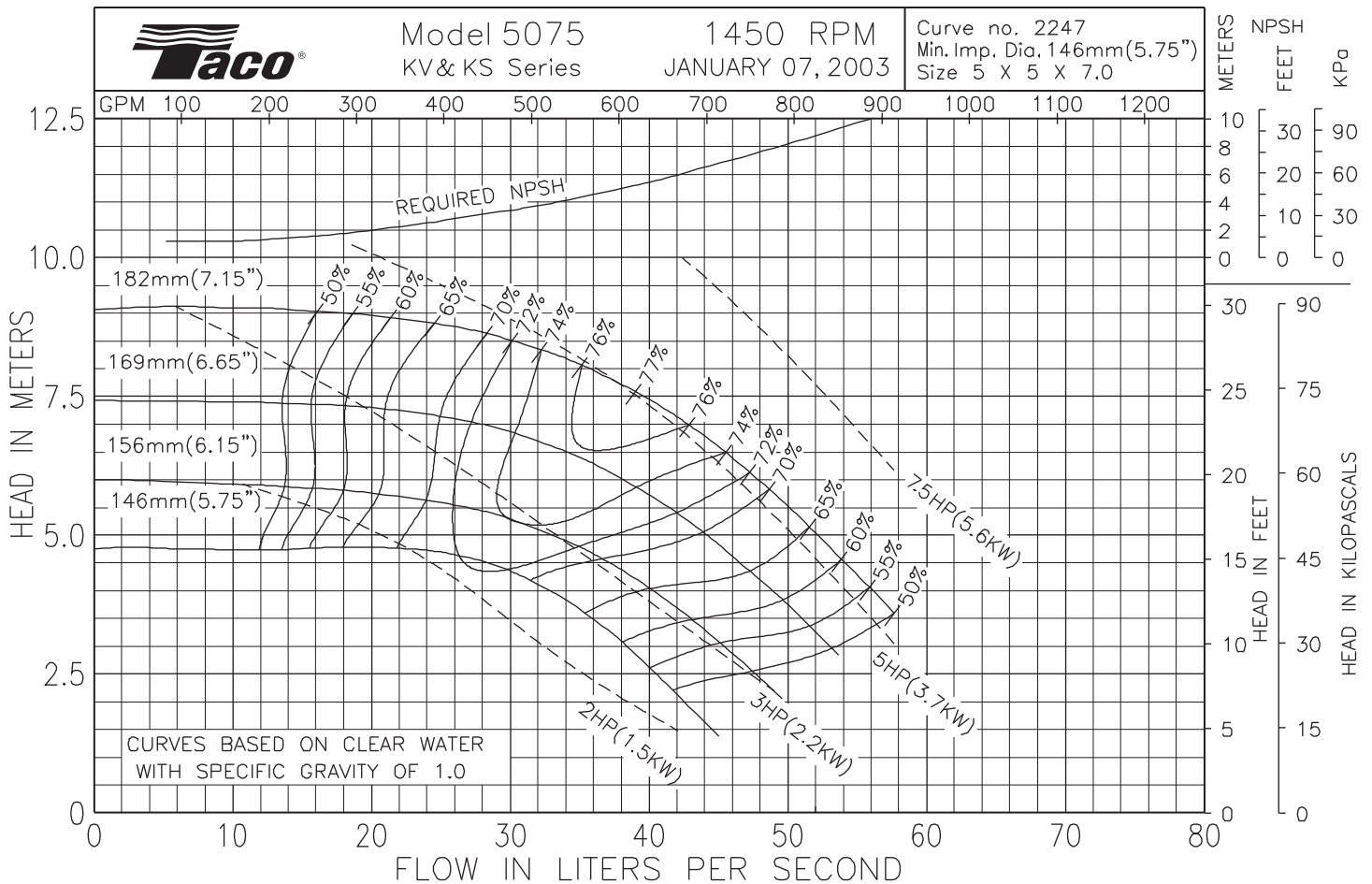

Comments:



Taco, Inc., 1160 Cranston Street, Cranston, RI 02920 | Tel: (401) 942-8000 | FAX: (401) 942-2360
Taco (Canada), Ltd., 8450 Lawson Road, Suite #3, Milton, Ontario L9T 0J8 | Tel: (905) 564-9422 | FAX: (905) 564-9436
 Visit our web site: www.TacoComfort.com | Printed in USA | ©2017 Taco, Inc.





Submittal Data Information

KS Series Vertical Split Coupled Pumps (50 Hz)

301-1226 I

EFFECTIVE: MAY 31, 2017

SUPERSEDES: JANUARY 8, 2010

2900 RPM MODEL 5075

JOB _____ ENGINEER _____

CONTRACTOR _____ REP. _____

ITEM NO.	MODEL NO.	IMPELLER DIA.	G.P.M.	HEAD/FT.	H.P.	ELEC. CHAR.

WEIGHT _____ PUMP/MOTOR _____

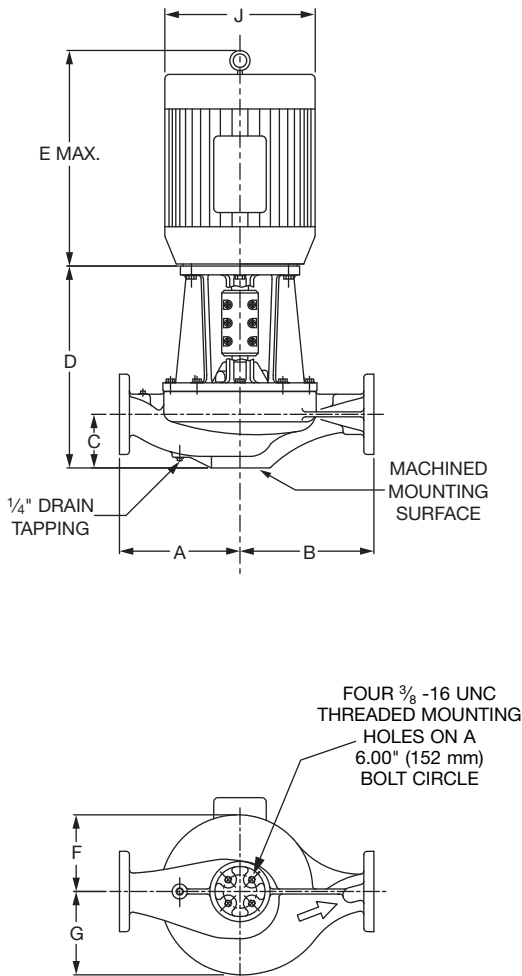

PUMP WITH OPTIONAL SUPPORT STAND

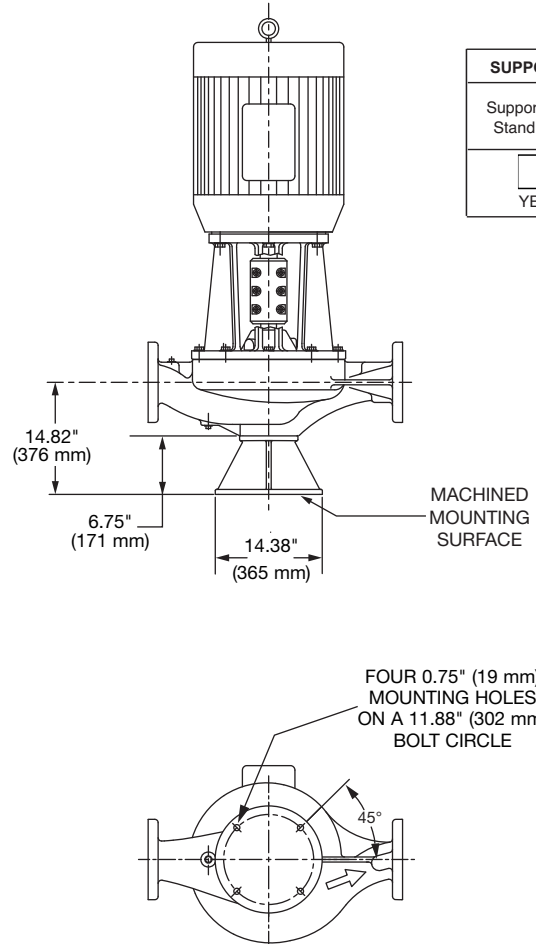

SUPPORT STAND OPTION	
Support Stand	Ductile Iron ASTM A536-84 Grade 65-45-12
<input type="checkbox"/>	<input type="checkbox"/>
YES	NO

DIMENSIONS

*A & B Dimensions apply for all pump sizes.

Model No.	Conn.	Motor Frame	HP 2900 RPM	Flange Size ASA	A*	B*	C	D	E MAX	F	G	H	J DIA
5075	5 x 5 (127 x 127)	215CZ	15	5 (127)	14.00 (355) if ANSI Class 125	11.00 (279) if ANSI Class 125	8.07 (205)	19.65 (499)	20.63 (524)	6.31 (160)	8.10 (205)	0.25 (6)	10.18 (259)
		254CZ	20					22.89 (581)	24.36 (619)				12.88 (327)
		256CZ	25					22.89 (581)	26.11 (663)				12.88 (327)
		284CZ	30		22.89 (581)	27.94 (710)		14.63 (372)					
		286CZ	40		22.89 (581)	29.14 (740)		14.63 (372)					
					14.44 (366) if ANSI Class 250	11.44 (291) if ANSI Class 250							

English dimensions are in inches. Metric dimensions are in millimeters. Metric data is presented in ().
Do not use for construction purposes unless certified.

MATERIALS OF CONSTRUCTION

	BRONZE FITTED		
	STANDARD PUMP CONSTRUCTION		OPTIONAL
	125# Flange	250# Flange	125# or 250#
Casing	Cast Iron ASTM A48/ A48M-03 Class 30A	Ductile Iron ASTM A536-84 Grade 65-45-12	N/A
Impeller	Bronze ASTM B584 ALLOY C83600 or C84400	Bronze ASTM B584 ALLOY C83600 or C84400	N/A
Wear Ring	N/A	N/A	Bronze ASTM B584-98A C92200
Shaft	Stainless Steel TYPE 416"™" or 410"™" ASTM A582	Stainless Steel TYPE 416"™" or 410"™" ASTM A582	N/A
Coupling	Aluminum Alloy 6061-T6	Aluminum Alloy 6061-T6	N/A
Mechanical Seal	Ceramic/EPT	Ceramic/EPT	Tungsten Carbide/EPT or Silicon-Carbide/EPT
Seal Flush Line	Copper & Brass C3600	Copper & Brass C3600	N/A

NA = Not available

Revised: 05/31/2017

OPERATING SPECIFICATIONS

	Standard		Optional
Flange	ANSI Class 125	ANSI Class 250	
Pressure	175 PSIG* (1210 KPA)	300 PSIG** (2070 KPA)	CF
Temperature	250°F (120°C)	250°F (120°C)	CF

Motors: All NEMA Standard ODP Frame (CZ Shaft)
 * In accordance with ANSI Standard B16.1 Class 125
 ** In accordance with ANSI Standard B16.1 Class 250 Dim.

MAXIMUM ASSEMBLY WEIGHT

Motor Frame	Weight without Optional Stand Lbs (Kg)	Weight with Optional Stand Lbs (Kg)
213CZ - 215CZ	625 (283)	691 (313)
254CZ - 256CZ	720 (327)	786 (357)
284CZ - 286CZ	856 (388)	922 (418)

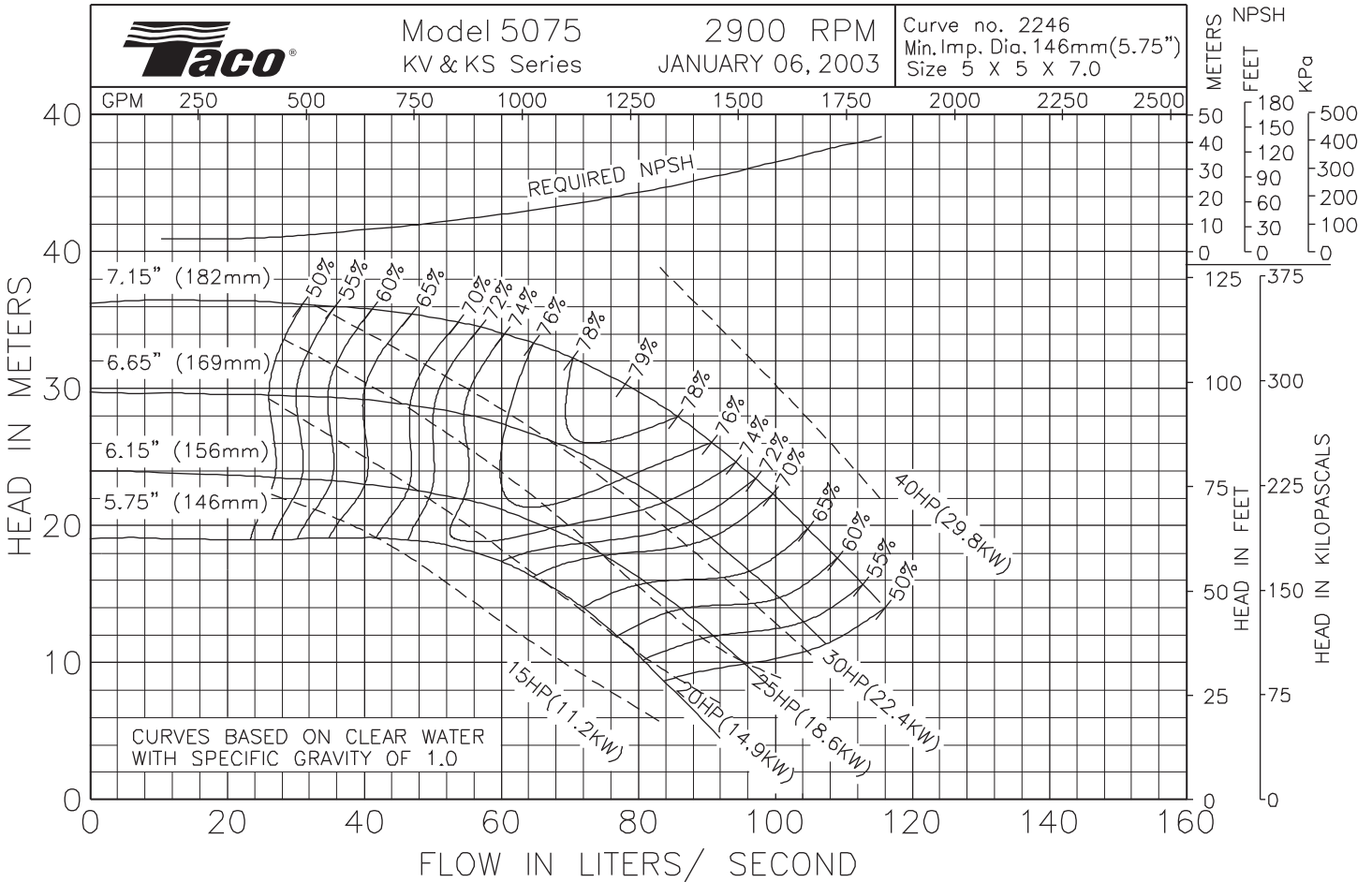

Comments:



Taco, Inc., 1160 Cranston Street, Cranston, RI 02920 | Tel: (401) 942-8000 | FAX: (401) 942-2360

Taco (Canada), Ltd., 8450 Lawson Road, Suite #3, Milton, Ontario L9T 0J8 | Tel: (905) 564-9422 | FAX: (905) 564-9436

Visit our web site: www.TacoComfort.com | Printed in USA | ©2017 Taco, Inc.

