



# Submittal Data Information

## KS Series Vertical Split Coupled Pumps

301-1141

EFFECTIVE: MAY 31, 2017

SUPERSEDES: JUNE 25, 2016

1160 RPM MODEL 3007

JOB \_\_\_\_\_ ENGINEER \_\_\_\_\_

CONTRACTOR \_\_\_\_\_ REP. \_\_\_\_\_

ITEM NO.	MODEL NO.	IMPELLER DIA.	G.P.M.	HEAD/FT.	H.P.	ELEC. CHAR.
----------	-----------	---------------	--------	----------	------	-------------

NSF 61 Certified

Yes  No

WEIGHT \_\_\_\_\_ PUMP/MOTOR \_\_\_\_\_

### PUMP WITH OPTIONAL SUPPORT STAND

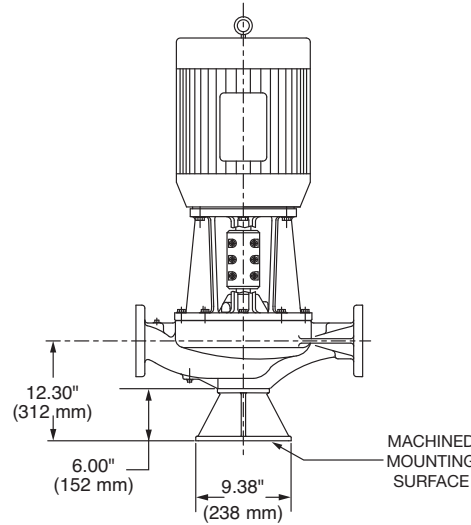
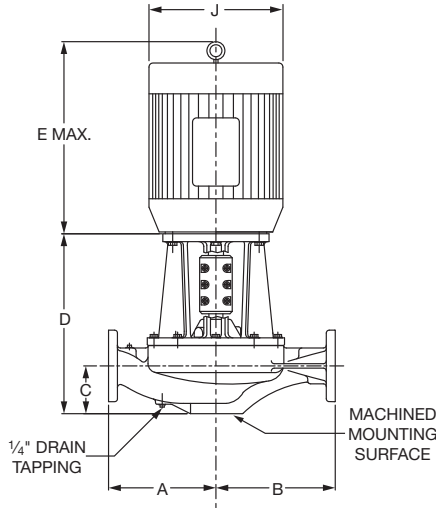

SUPPORT STAND OPTION	
Support Stand	Ductile Iron ASTM A536-84 Grade 65-45-12
<input type="checkbox"/> YES	<input type="checkbox"/> NO

FOUR 3/8 -16 UNC  
THREADED MOUNTING  
HOLES ON A  
2.88" (73 mm)  
BOLT CIRCLE

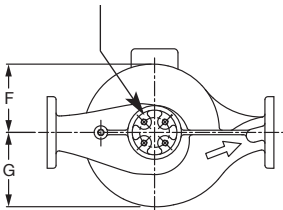

FOUR 0.63" (16 mm)  
MOUNTING HOLES  
ON A 7.75" (197 mm)  
BOLT CIRCLE

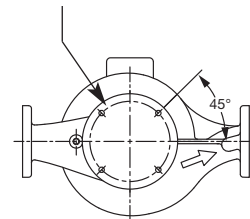

### OPERATING SPECIFICATIONS

	Standard		Optional
	ANSI Class 125	ANSI Class 250	
Flange	ANSI Class 125	ANSI Class 250	
Pressure	175 PSIG* (1210 KPA)	300 PSIG** (2070 KPA)	CF
Temperature	250°F (120°C)	250°F (120°C)	CF

Motors: All NEMA Standard ODP Frame (CZ Shaft)  
\* In accordance with ANSI Standard B16.1 Class 125  
\*\* In accordance with ANSI Standard B16.1 Class 250 Dim.

### MAXIMUM ASSEMBLY WEIGHT

Motor Frame	Weight without Optional Stand Lbs (Kg)	Weight with Optional Stand Lbs (Kg)
143CZ - 145CZ	224 (102)	243 (110)
182CZ - 184CZ	238 (108)	257 (117)

### DIMENSIONS

\*A & B Dimensions apply for all pump sizes.

Model No.	Conn.	Motor Frame	HP 1160 RPM	Flange Size ASA	A*	B*	C	D	E MAX	F	G	H	J DIA
3007	3 x 3 (76 x 76)	143CZ	0.75	3 (76)	10.00 (254) if ANSI Class 125	10.00 (254) if ANSI Class 125	6.30 (160)	16.96 (431)	13.05 (331)	5.29 (134)	6.31 (160)	0.25 (6)	7.05 (179)
		145CZ	1					16.96 (431)	14.05 (357)				7.05 (179)
		182CZ	1.5					16.96 (431)	15.64 (397)				8.49 (216)
					10.37 (263) if ANSI Class 250	10.37 (263) if ANSI Class 250							

English dimensions are in inches. Metric dimensions are in millimeters. Metric data is presented in ( ).  
Do not use for construction purposes unless certified.

## MATERIALS OF CONSTRUCTION

	BRONZE FITTED			NSF 61		
	STANDARD PUMP CONSTRUCTION		OPTIONAL	STANDARD PUMP CONSTRUCTION		OPTIONAL
	125# Flange	250# Flange	125# or 250#	125# Flange	250# Flange	125# or 250#
Casing	Cast Iron ASTM A48/ A48M-03 Class 30A	Ductile Iron ASTM A536-84 Grade 65-45-12	N/A	Cast Iron ASTM A48/A48M-03 Class 30A	Ductile Iron ASTM A536-84 Grade 65-45-12	N/A
Impeller	Bronze ASTM B584 ALLOY C83600 or C84400	Bronze ASTM B584 ALLOY C83600 or C84400	N/A	Stainless Steel ASTM A351/A 351M-08	Stainless Steel ASTM A351/A 351M-08	N/A
Wear Ring	N/A	N/A	Bronze ASTM B584-98A C92200	N/A	N/A	Bronze ASTM B584-98A C92200
Shaft	Stainless Steel TYPE 416"™" or 410"™" ASTM A582	Stainless Steel TYPE 416"™" or 410"™" ASTM A582	N/A	Stainless Steel TYPE 416"™" or 410"™" ASTM A582	Stainless Steel TYPE 416"™" or 410"™" ASTM A582	N/A
Coupling	Aluminum Alloy 6061-T6	Aluminum Alloy 6061-T6	N/A	Aluminum Alloy 6061-T6	Bronze ASTM B584-98A C92200	N/A
Mechanical Seal	Ceramic/EPT	Ceramic/EPT	Tungsten Carbide/EPT or Silicon Carbide/EPT	Ceramic/EPT	Ceramic/EPT	N/A
Seal Flush Line	Copper & Brass C3600	Copper & Brass C3600	N/A	Copper & Brass C3600	Copper & Brass C3600	N/A

N/A = Not available

Revised: 05/31/2017

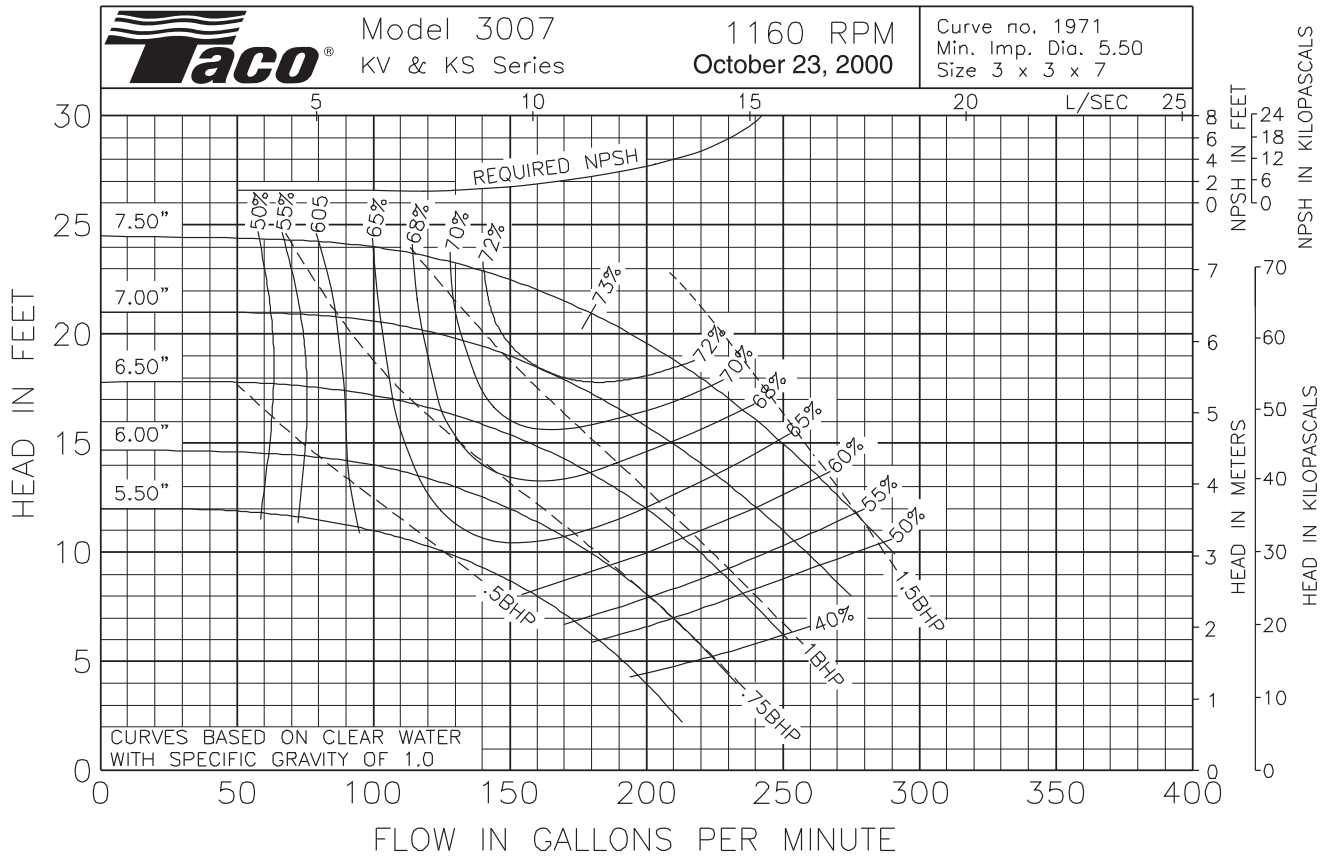

Comments: \_\_\_\_\_

**Taco Comfort Solutions**® A Taco Family Company

Taco, Inc., 1160 Cranston Street, Cranston, RI 02920 | Tel: (401) 942-8000 | FAX: (401) 942-2360

Taco (Canada), Ltd., 8450 Lawson Road, Suite #3, Milton, Ontario L9T 0J8 | Tel: (905) 564-9422 | FAX: (905) 564-9436

Visit our web site: [www.TacoComfort.com](http://www.TacoComfort.com) | Printed in USA | ©2017 Taco, Inc.





# Submittal Data Information

## KS Series Vertical Split Coupled Pumps

301-1155

EFFECTIVE: MAY 31, 2017

SUPERSEDES: JUNE 25, 2016

1760 RPM MODEL 3007

JOB \_\_\_\_\_ ENGINEER \_\_\_\_\_

CONTRACTOR \_\_\_\_\_ REP. \_\_\_\_\_

ITEM NO.	MODEL NO.	IMPELLER DIA.	G.P.M.	HEAD/FT.	H.P.	ELEC. CHAR.
----------	-----------	---------------	--------	----------	------	-------------

NSF 61 Certified  
 Yes  No

WEIGHT \_\_\_\_\_ PUMP/MOTOR \_\_\_\_\_

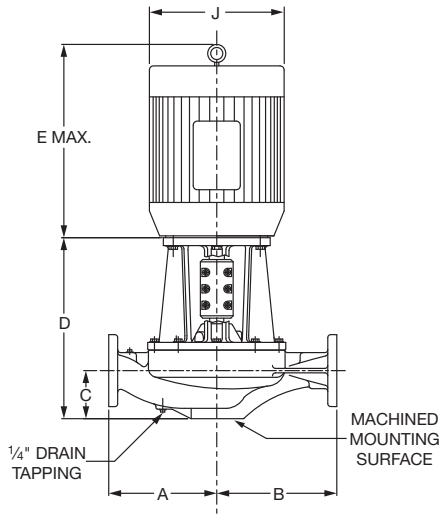

### PUMP WITH OPTIONAL SUPPORT STAND

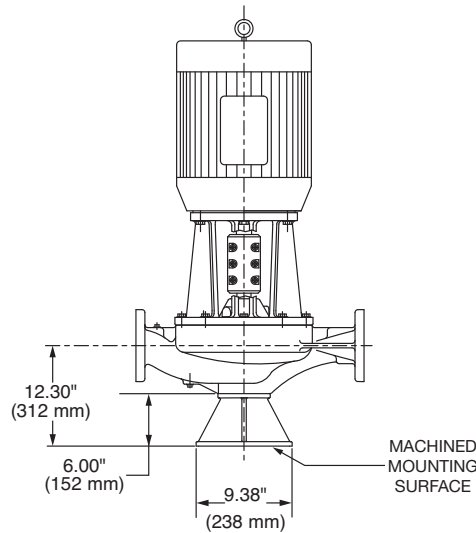

SUPPORT STAND OPTION	
Support Stand	Ductile Iron ASTM A536-84 Grade 65-45-12
<input type="checkbox"/> YES	<input type="checkbox"/> NO

FOUR 3/8\" -16 UNC  
THREADED MOUNTING  
HOLES ON A  
2.88\" (73 mm)  
BOLT CIRCLE

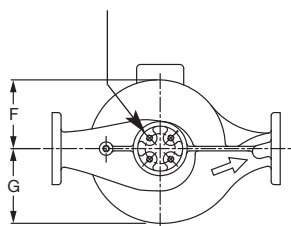

FOUR 0.63\" (16 mm)  
MOUNTING HOLES  
ON A 7.75\" (197 mm)  
BOLT CIRCLE

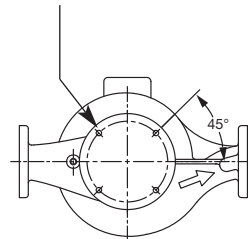

### OPERATING SPECIFICATIONS

	Standard		Optional
	ANSI Class 125	ANSI Class 250	
Flange	ANSI Class 125	ANSI Class 250	
Pressure	175 PSIG* (1210 KPA)	300 PSIG** (2070 KPA)	CF
Temperature	250°F (120°C)	250°F (120°C)	CF

Motors: All NEMA Standard ODP Frame (CZ Shaft)  
 \* In accordance with ANSI Standard B16.1 Class 125  
 \*\* In accordance with ANSI Standard B16.1 Class 250 Dim.

### MAXIMUM ASSEMBLY WEIGHT

Motor Frame	Weight without Optional Stand Lbs (Kg)	Weight with Optional Stand Lbs (Kg)
143CZ - 145CZ	229 (104)	248 (112)
182CZ - 184CZ	270 (122)	289 (131)
213CZ - 215CZ	332 (151)	351 (159)

### DIMENSIONS

\*A & B Dimensions apply for all pump sizes.

Model No.	Conn.	Motor Frame	HP 1760 RPM	Flange Size ASA	A*	B*	C	D	E MAX	F	G	H	J DIA
3007	3 x 3 (76 x 76)	145CZ	1.5	3 (76)	10.00 (254) if ANSI Class 125	10.00 (254) if ANSI Class 125	6.30	16.96 (431)	14.05 (357)	5.29	6.31	0.25	7.05 (179)
			2					16.96 (431)	14.05 (357)				7.05 (179)
			3					16.96 (431)	15.64 (397)				8.49 (216)
			5					16.96 (431)	16.68 (424)				8.49 (216)
			7.5					16.96 (431)	19.13 (486)				10.18 (259)

English dimensions are in inches. Metric dimensions are in millimeters. Metric data is presented in ( ).  
 Do not use for construction purposes unless certified.

### MATERIALS OF CONSTRUCTION

	BRONZE FITTED			NSF 61		
	STANDARD PUMP CONSTRUCTION		OPTIONAL	STANDARD PUMP CONSTRUCTION		OPTIONAL
	125# Flange	250# Flange	125# or 250#	125# Flange	250# Flange	125# or 250#
Casing	Cast Iron ASTM A48/ A48M-03 Class 30A	Ductile Iron ASTM A536-84 Grade 65-45-12	N/A	Cast Iron ASTM A48/A48M-03 Class 30A	Ductile Iron ASTM A536-84 Grade 65-45-12	N/A
Impeller	Bronze ASTM B584 ALLOY C83600 or C84400	Bronze ASTM B584 ALLOY C83600 or C84400	N/A	Stainless Steel ASTM A351/A 351M-08	Stainless Steel ASTM A351/A 351M-08	N/A
Wear Ring	N/A	N/A	Bronze ASTM B584-98A C92200	N/A	N/A	Bronze ASTM B584-98A C92200
Shaft	Stainless Steel TYPE 416"™" or 410"™" ASTM A582	Stainless Steel TYPE 416"™" or 410"™" ASTM A582	N/A	Stainless Steel TYPE 416"™" or 410"™" ASTM A582	Stainless Steel TYPE 416"™" or 410"™" ASTM A582	N/A
Coupling	Aluminum Alloy 6061-T6	Aluminum Alloy 6061-T6	N/A	Aluminum Alloy 6061-T6	Bronze ASTM B584-98A C92200	N/A
Mechanical Seal	Ceramic/EPT	Ceramic/EPT	Tungsten Carbide/EPT or Silicon-Carbide/EPT	Ceramic/EPT	Ceramic/EPT	N/A
Seal Flush Line	Copper & Brass C3600	Copper & Brass C3600	N/A	Copper & Brass C3600	Copper & Brass C3600	N/A

N/A = Not available

Revised: 05/31/2017

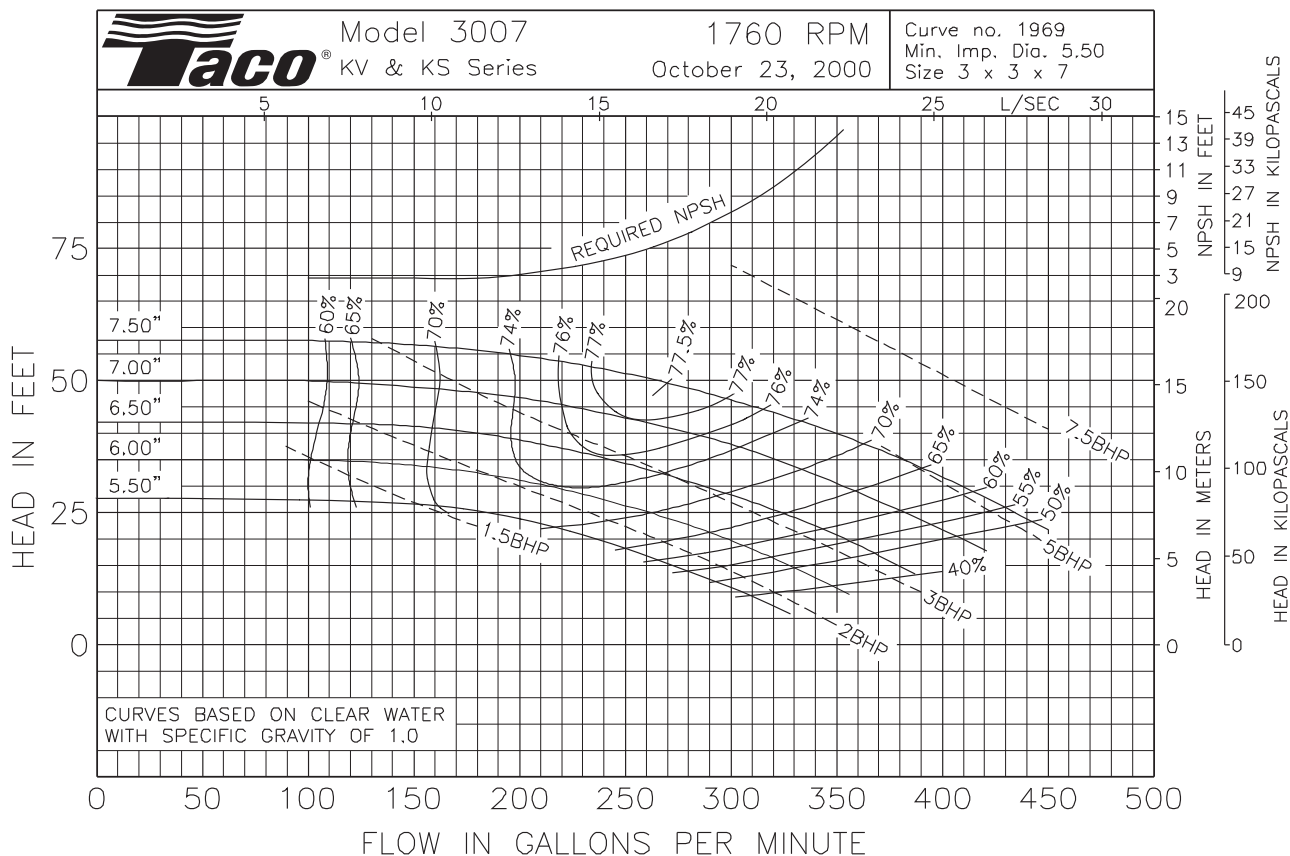

Comments: \_\_\_\_\_



**Taco, Inc.**, 1160 Cranston Street, Cranston, RI 02920 | Tel: (401) 942-8000 | FAX: (401) 942-2360

**Taco (Canada), Ltd.**, 8450 Lawson Road, Suite #3, Milton, Ontario L9T 0J8 | Tel: (905) 564-9422 | FAX: (905) 564-9436

Visit our web site: [www.TacoComfort.com](http://www.TacoComfort.com) | Printed in USA | ©2017 Taco, Inc.





# Submittal Data Information

## KS Series Vertical Split Coupled Pumps

301-1169

EFFECTIVE: MAY 31, 2017

SUPERSEDES: JUNE 25, 2016

3500 RPM MODEL 3007

JOB \_\_\_\_\_ ENGINEER \_\_\_\_\_

CONTRACTOR \_\_\_\_\_ REP. \_\_\_\_\_

ITEM NO.	MODEL NO.	IMPELLER DIA.	G.P.M.	HEAD/FT.	H.P.	ELEC. CHAR.
----------	-----------	---------------	--------	----------	------	-------------

NSF 61 Certified  
 Yes  No

WEIGHT \_\_\_\_\_ PUMP/MOTOR \_\_\_\_\_

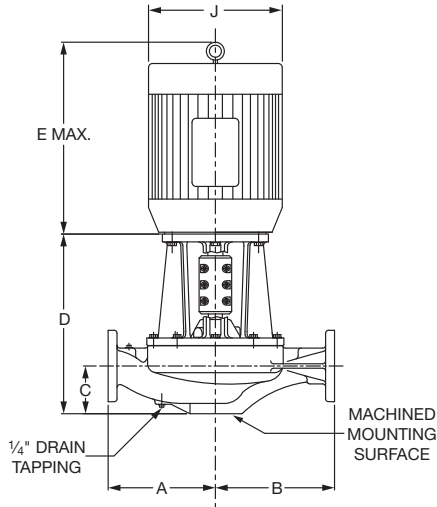

### PUMP WITH OPTIONAL SUPPORT STAND

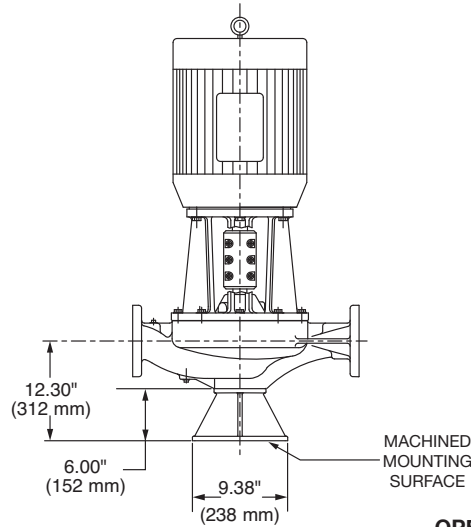

SUPPORT STAND OPTION	
Support Stand	Ductile Iron ASTM A536-84 Grade 65-45-12
<input type="checkbox"/> YES	<input type="checkbox"/> NO

FOUR 3/8 -16 UNC  
 THREADED MOUNTING  
 HOLES ON A  
 2.88" (73 mm)  
 BOLT CIRCLE

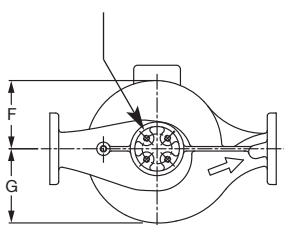

FOUR 0.63" (16 mm)  
 MOUNTING HOLES  
 ON A 7.75" (197 mm)  
 BOLT CIRCLE

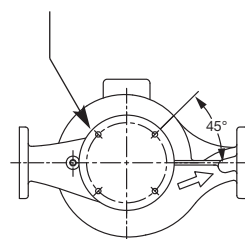

### OPERATING SPECIFICATIONS

	Standard		Optional
	ANSI Class 125	ANSI Class 250	
Flange			
Pressure	175 PSIG* (1210 KPA)	300 PSIG** (2070 KPA)	CF
Temperature	250°F (120°C)	250°F (120°C)	CF

Motors: All NEMA Standard ODP Frame (CZ Shaft)  
 \* In accordance with ANSI Standard B16.1 Class 125  
 \*\* In accordance with ANSI Standard B16.1 Class 250 Dim.

### MAXIMUM ASSEMBLY WEIGHT

Motor Frame	Weight without Optional Stand Lbs (Kg)	Weight with Optional Stand Lbs (Kg)
213CZ - 215CZ	353 (160)	372 (169)
254CZ - 256CZ	561 (254)	580 (263)
284CZ - 286CZ	688 (312)	707 (321)

### DIMENSIONS

\*A & B Dimensions apply for all pump sizes.

Model No.	Conn.	Motor Frame	HP 3500 RPM	Flange Size ASA	A*	B*	C	D	E MAX	F	G	H	J DIA
3007	3 x 3 (76 x 76)	213CZ	10	3 (76)	10.00 (254) if ANSI Class 125	10.00 (254) if ANSI Class 125	6.30 (160)	16.96 (431)	19.13 (486)	5.29 (134)	6.31 (160)	0.25 (6)	10.18 (259)
		215CZ	15					16.96 (431)	20.63 (524)				10.18 (259)
		254CZ	20					20.20 (513)	24.36 (619)				12.88 (327)
		256CZ	25		20.20 (513)	26.11 (663)		12.88 (327)					
		284CZ	30		21.95 (558)	27.94 (710)		14.63 (371)					
		286CZ	40		21.95 (558)	29.14 (740)		14.63 (371)					

English dimensions are in inches. Metric dimensions are in millimeters. Metric data is presented in ( ).  
 Do not use for construction purposes unless certified.

## MATERIALS OF CONSTRUCTION

	BRONZE FITTED			NSF 61		
	STANDARD PUMP CONSTRUCTION		OPTIONAL	STANDARD PUMP CONSTRUCTION		OPTIONAL
	125# Flange	250# Flange	125# or 250#	125# Flange	250# Flange	125# or 250#
Casing	Cast Iron ASTM A48/ A48M-03 Class 30A	Ductile Iron ASTM A536-84 Grade 65-45-12	N/A	Cast Iron ASTM A48/A48M-03 Class 30A	Ductile Iron ASTM A536-84 Grade 65-45-12	N/A
Impeller	Bronze ASTM B584 ALLOY C83600 or C84400	Bronze ASTM B584 ALLOY C83600 or C84400	N/A	Stainless Steel ASTM A351/A 351M-08	Stainless Steel ASTM A351/A 351M-08	N/A
Wear Ring	N/A	N/A	Bronze ASTM B584-98A C92200	N/A	N/A	Bronze ASTM B584-98A C92200
Shaft	Stainless Steel TYPE 416"™" or 410"™" ASTM A582	Stainless Steel TYPE 416"™" or 410"™" ASTM A582	N/A	Stainless Steel TYPE 416"™" or 410"™" ASTM A582	Stainless Steel TYPE 416"™" or 410"™" ASTM A582	N/A
Coupling	Aluminum Alloy 6061-T6	Aluminum Alloy 6061-T6	N/A	Aluminum Alloy 6061-T6	Bronze ASTM B584-98A C92200	N/A
Mechanical Seal	Ceramic/EPT	Ceramic/EPT	Tungsten Carbide/EPT or Silicon-Carbide/EPT	Ceramic/EPT	Ceramic/EPT	N/A
Seal Flush Line	Copper & Brass C3600	Copper & Brass C3600	N/A	Copper & Brass C3600	Copper & Brass C3600	N/A

N/A = Not available

Revised: 05/31/2017

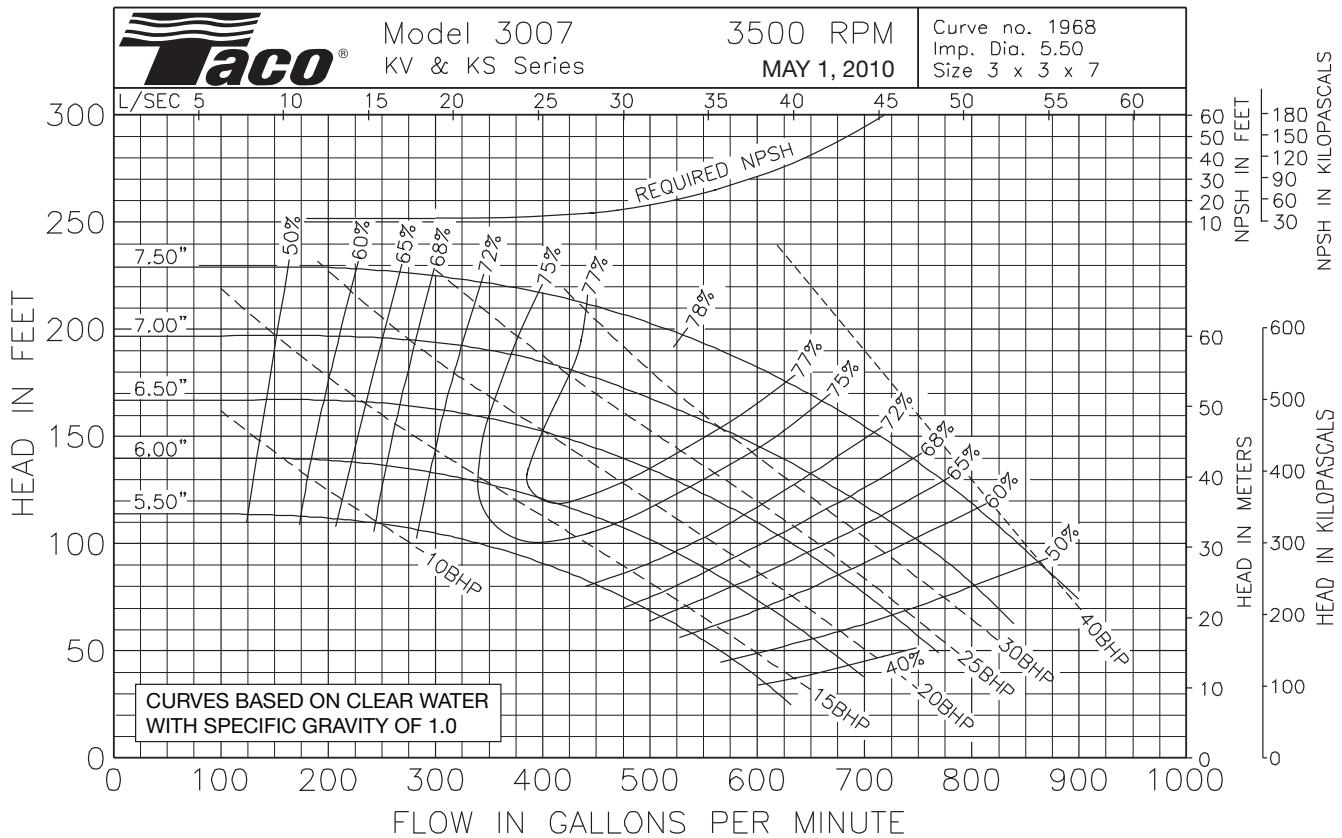

Comments: \_\_\_\_\_



**Taco Comfort Solutions**® A Taco Family Company

Taco, Inc., 1160 Cranston Street, Cranston, RI 02920 | Tel: (401) 942-8000 | FAX: (401) 942-2360

Taco (Canada), Ltd., 8450 Lawson Road, Suite #3, Milton, Ontario L9T 0J8 | Tel: (905) 564-9422 | FAX: (905) 564-9436

Visit our web site: [www.TacoComfort.com](http://www.TacoComfort.com) | Printed in USA | ©2017 Taco, Inc.





# Submittal Data Information

## KS Series Vertical Split Coupled Pumps (50 Hz)

301-1183 I

EFFECTIVE: MAY 31, 2017

SUPERSEDES: JANUARY 8, 2010

1450 RPM MODEL 3007

JOB \_\_\_\_\_ ENGINEER \_\_\_\_\_

CONTRACTOR \_\_\_\_\_ REP. \_\_\_\_\_

ITEM NO.	MODEL NO.	IMPELLER DIA.	G.P.M.	HEAD/FT.	H.P.	ELEC. CHAR.

WEIGHT \_\_\_\_\_ PUMP/MOTOR \_\_\_\_\_

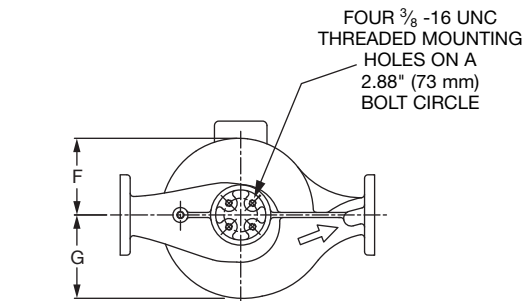
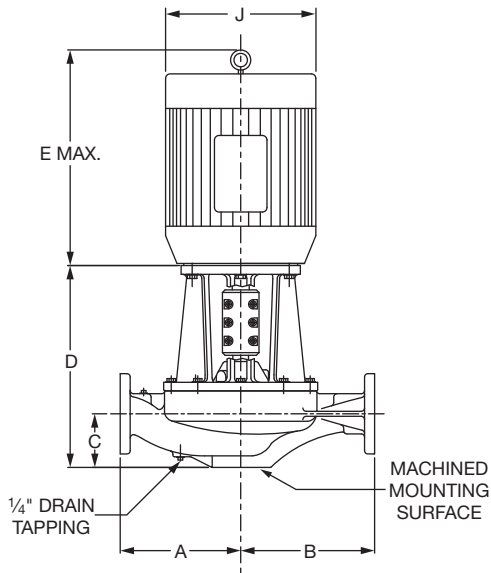

### PUMP WITH OPTIONAL SUPPORT STAND

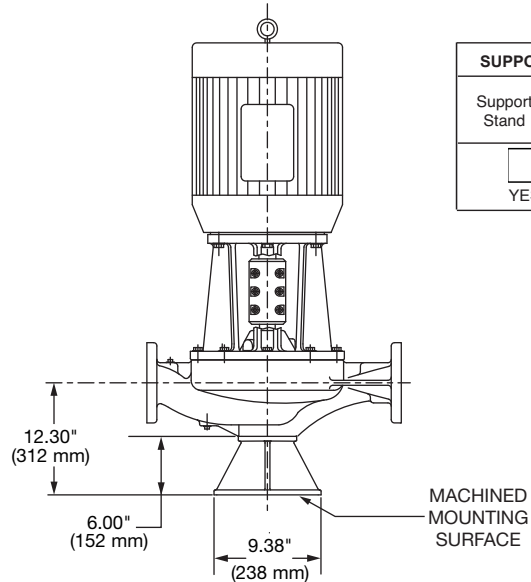

SUPPORT STAND OPTION	
Support Stand	Ductile Iron ASTM A536-84 Grade 65-45-12
<input type="checkbox"/>	<input type="checkbox"/>
YES	NO

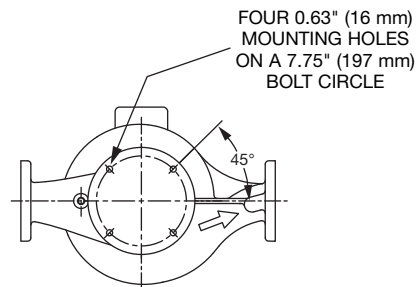

### DIMENSIONS

\*A & B Dimensions apply for all pump sizes.

Model No.	Conn.	Motor Frame	HP 1450 RPM	Flange Size ASA	A*	B*	C	D	E MAX	F	G	H	J DIA
3007	3 x 3 (76 x 76)	143CZ	1	3  (76)	10.00 (254) if ANSI Class 125	10.00 (254) if ANSI Class 125	6.30  (160)	16.96 (431)	13.05 (331)	5.29  (134)	6.31  (160)	0.25  (6)	7.05 (179)
		145CZ	1.5					16.96 (431)	14.05 (357)				7.05 (179)
			2					16.96 (431)	14.05 (357)				7.05 (179)
			3					16.96 (431)	15.64 (397)				8.49 (216)
		182CZ	3					10.37 (263) if ANSI Class 250	10.37 (263) if ANSI Class 250				

English dimensions are in inches. Metric dimensions are in millimeters. Metric data is presented in ( ).  
Do not use for construction purposes unless certified.



**MATERIALS OF CONSTRUCTION**

	BRONZE FITTED		
	STANDARD PUMP CONSTRUCTION		OPTIONAL
	125# Flange	250# Flange	125# or 250#
Casing	Cast Iron ASTM A48/ A48M-03 Class 30A	Ductile Iron ASTM A536-84 Grade 65-45-12	N/A
Impeller	Bronze ASTM B584 ALLOY C83600 or C84400	Bronze ASTM B584 ALLOY C83600 or C84400	N/A
Wear Ring	N/A	N/A	Bronze ASTM B584-98A C92200
Shaft	Stainless Steel TYPE 416"TI" or 410"TI" ASTM A582	Stainless Steel TYPE 416"TI" or 410"TI" ASTM A582	N/A
Coupling	Aluminum Alloy 6061-T6	Aluminum Alloy 6061-T6	N/A
Mechanical Seal	Ceramic/EPT	Ceramic/EPT	Tungsten Carbide/EPT or Silicon-Carbide/EPT
Seal Flush Line	Copper & Brass C3600	Copper & Brass C3600	N/A

N/A = Not available

Revised: 05/31/2017

**OPERATING SPECIFICATIONS**

	Standard		Optional
Flange	ANSI Class 125	ANSI Class 250	
Pressure	175 PSIG* (1210 KPA)	300 PSIG** (2070 KPA)	CF
Temperature	250°F (120°C)	250°F (120°C)	CF

Motors: All NEMA Standard ODP Frame (CZ Shaft)  
 \* In accordance with ANSI Standard B16.1 Class 125  
 \*\* In accordance with ANSI Standard B16.1 Class 250 Dim.

**MAXIMUM ASSEMBLY WEIGHT**

Motor Frame	Weight without Optional Stand Lbs (Kg)	Weight with Optional Stand Lbs (Kg)
143CZ - 145CZ	252 (114)	271 (123)
182CZ - 184CZ	297 (135)	316 (143)

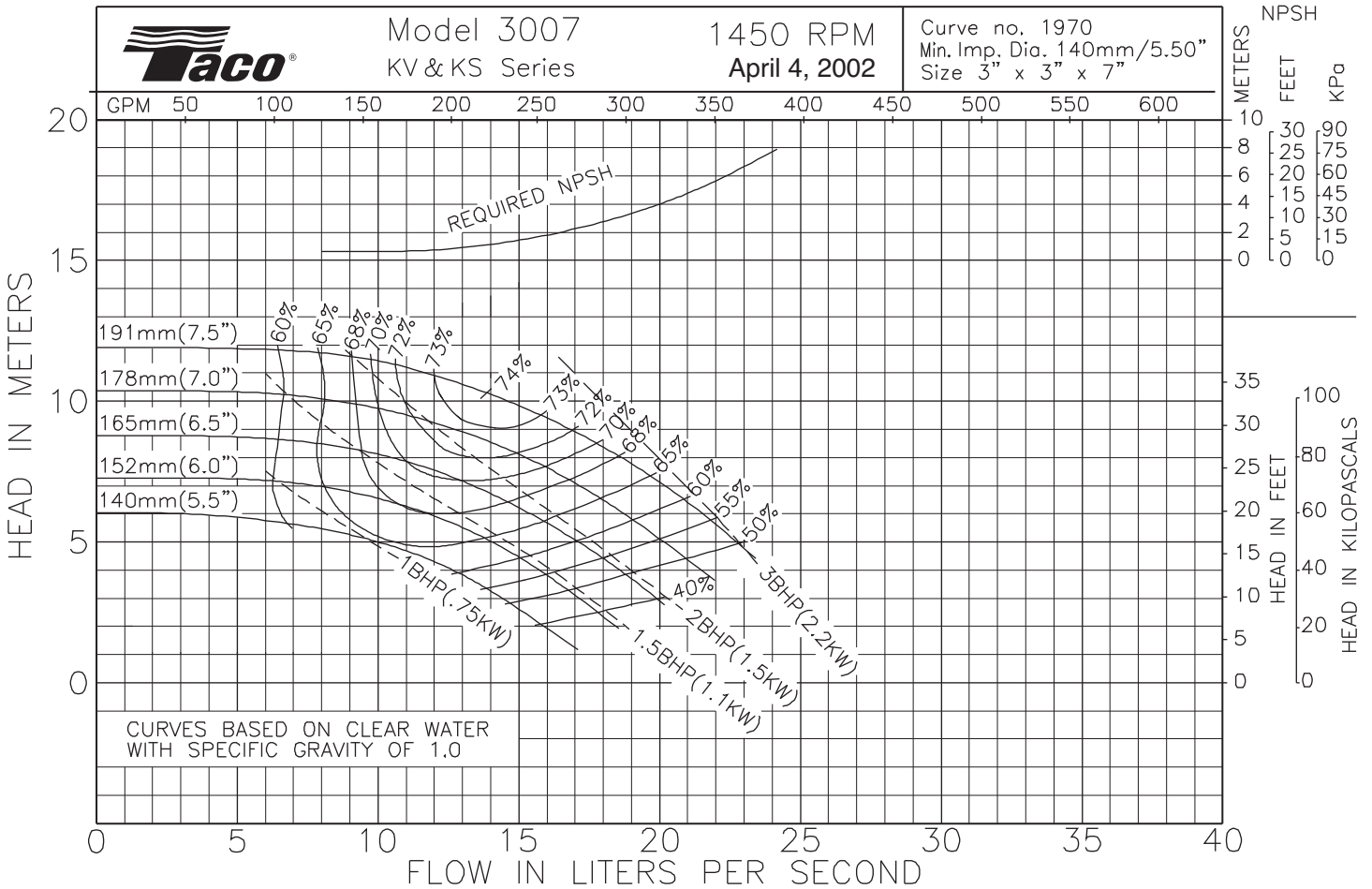

Comments:





# Submittal Data Information

## KS Series Vertical Split Coupled Pumps (50 Hz)

301-1215 I

EFFECTIVE: MAY 31, 2017

SUPERSEDES: JANUARY 8, 2010

2900 RPM MODEL 3007

JOB \_\_\_\_\_ ENGINEER \_\_\_\_\_

CONTRACTOR \_\_\_\_\_ REP. \_\_\_\_\_

ITEM NO.	MODEL NO.	IMPELLER DIA.	G.P.M.	HEAD/FT.	H.P.	ELEC. CHAR.

WEIGHT \_\_\_\_\_ PUMP/MOTOR \_\_\_\_\_

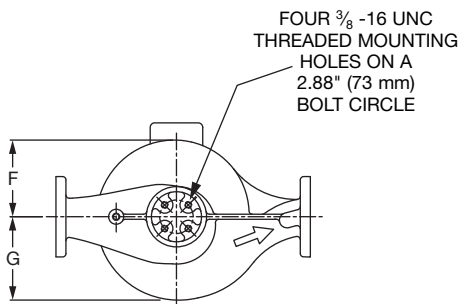
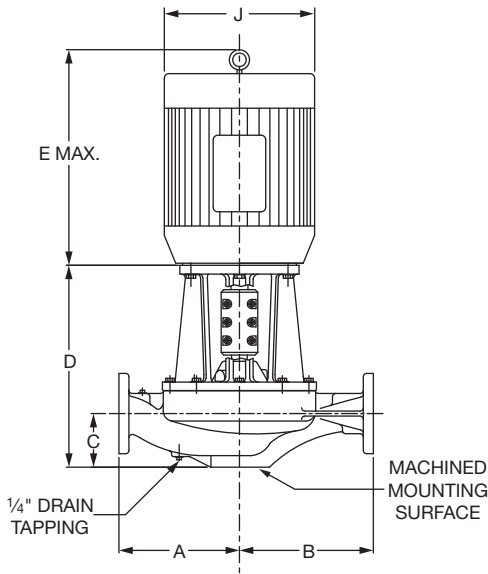

### PUMP WITH OPTIONAL SUPPORT STAND

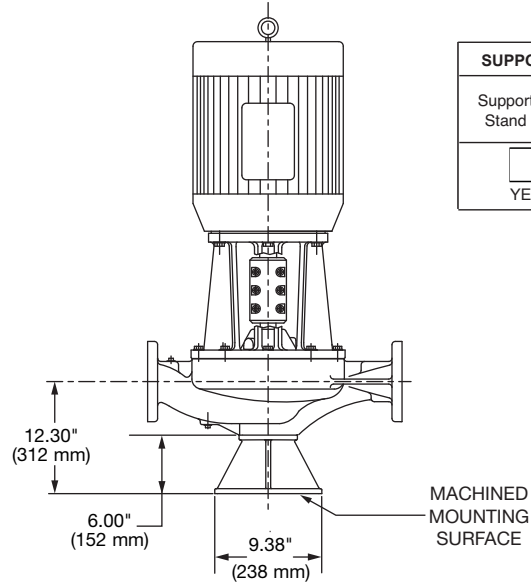

SUPPORT STAND OPTION	
Support Stand	Ductile Iron ASTM A536-84 Grade 65-45-12
<input type="checkbox"/>	<input type="checkbox"/>
YES	NO

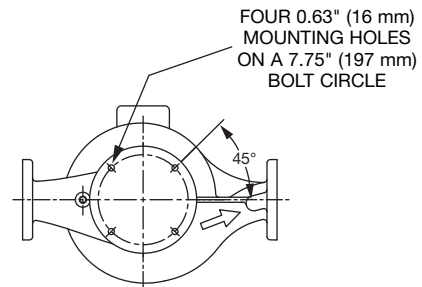

### DIMENSIONS

\*A & B Dimensions apply for all pump sizes.

Model No.	Conn.	Motor Frame	HP 2900 RPM	Flange Size ASA	A*	B*	C	D	E MAX	F	G	H	J DIA
3007	3 x 3 (76 x 76)	184CZ	7.5	3 (76)	10.00 (254) if ANSI Class 125	10.00 (254) if ANSI Class 125	6.30  (160)	16.96 (431)	16.68 (424)	5.29  (134)	6.31  (160)	0.25  (6)	8.49 (216)
		213CZ	10					16.96 (431)	19.13 (486)				10.18 (259)
		215CZ	15					16.96 (431)	20.63 (524)				10.18 (259)
		254CZ	20		20.20 (513)	24.36 (619)		12.88 (327)					
		256CZ	25		20.20 (513)	26.11 (663)		12.88 (327)					

English dimensions are in inches. Metric dimensions are in millimeters. Metric data is presented in ( ).  
Do not use for construction purposes unless certified.

**MATERIALS OF CONSTRUCTION**

	BRONZE FITTED		
	STANDARD PUMP CONSTRUCTION		OPTIONAL 125# or 250#
	125# Flange	250# Flange	
Casing	Cast Iron ASTM A48/ A48M-03 Class 30A	Ductile Iron ASTM A536-84 Grade 65-45-12	N/A
Impeller	Bronze ASTM B584 ALLOY C83600 or C84400	Bronze ASTM B584 ALLOY C83600 or C84400	N/A
Wear Ring	N/A	N/A	Bronze ASTM B584-98A C92200
Shaft	Stainless Steel TYPE 416"TI" or 410"TI" ASTM A582	Stainless Steel TYPE 416"TI" or 410"TI" ASTM A582	N/A
Coupling	Aluminum Alloy 6061-T6	Aluminum Alloy 6061-T6	N/A
Mechanical Seal	Ceramic/EPT	Ceramic/EPT	Tungsten Carbide/EPT or Silicon-Carbide/EPT
Seal Flush Line	Copper & Brass C3600	Copper & Brass C3600	N/A

N/A = Not available

Revised: 05/31/2017

**OPERATING SPECIFICATIONS**

	Standard		Optional
Flange	ANSI Class 125	ANSI Class 250	
Pressure	175 PSIG* (1210 KPA)	300 PSIG** (2070 KPA)	CF
Temperature	250°F (120°C)	250°F (120°C)	CF

Motors: All NEMA Standard ODP Frame (CZ Shaft)  
 \* In accordance with ANSI Standard B16.1 Class 125  
 \*\* In accordance with ANSI Standard B16.1 Class 250 Dim.

**MAXIMUM ASSEMBLY WEIGHT**

Motor Frame	Weight without Optional Stand Lbs (Kg)	Weight with Optional Stand Lbs (Kg)
182CZ - 184CZ	326 (148)	345 (156)
213CZ - 215CZ	388 (176)	407 (185)
254CZ - 256CZ	617 (280)	636 (288)

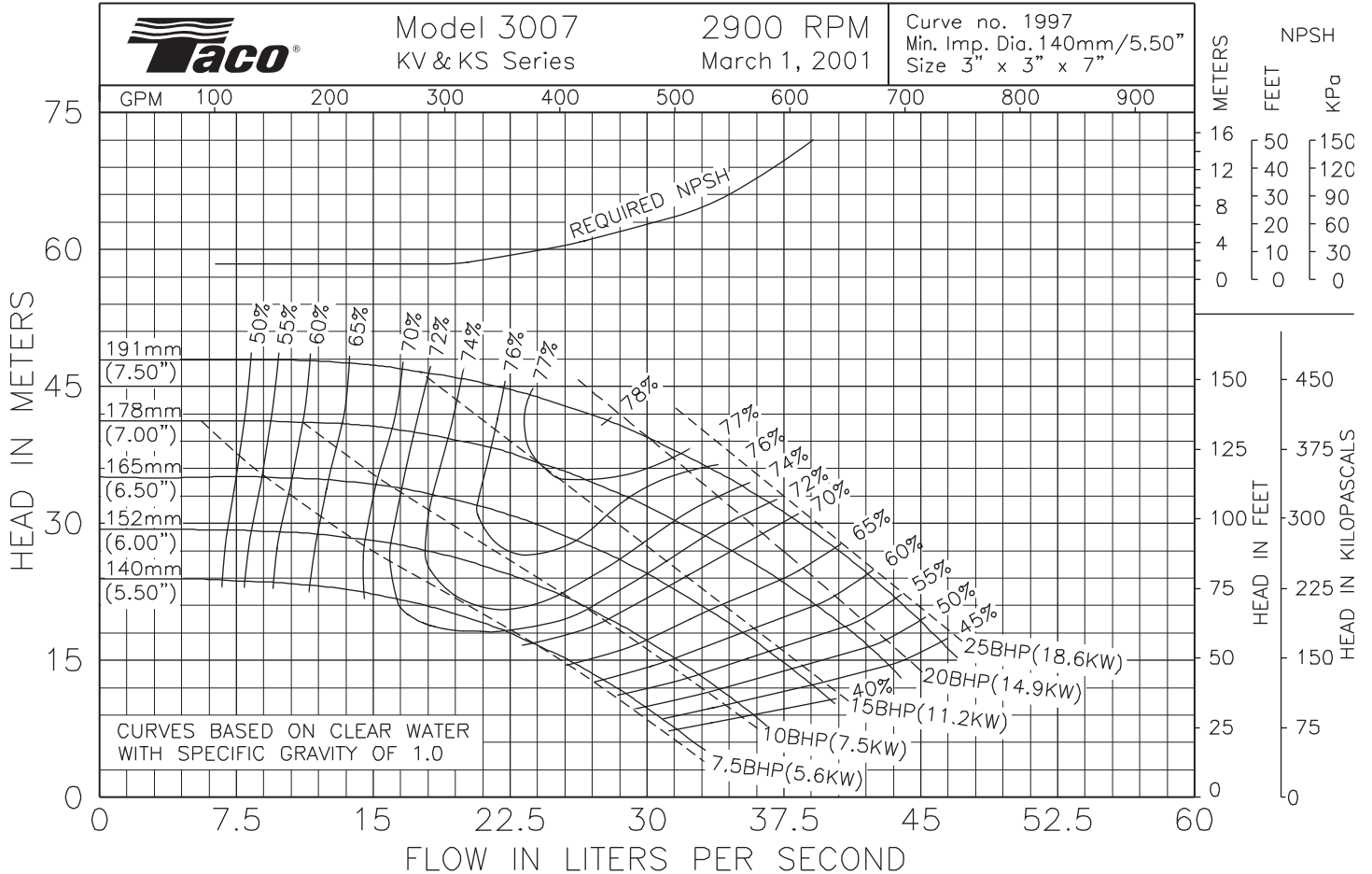

Comments: