



Replacement Parts List

304- 346

KS 2011

SUPERSEDES: January 31, 2004

EFFECTIVE: November 1, 2009

WHEN SELECTING AND ORDERING PARTS, ALWAYS REFER TO SERIAL NUMBER ON NAMEPLATE

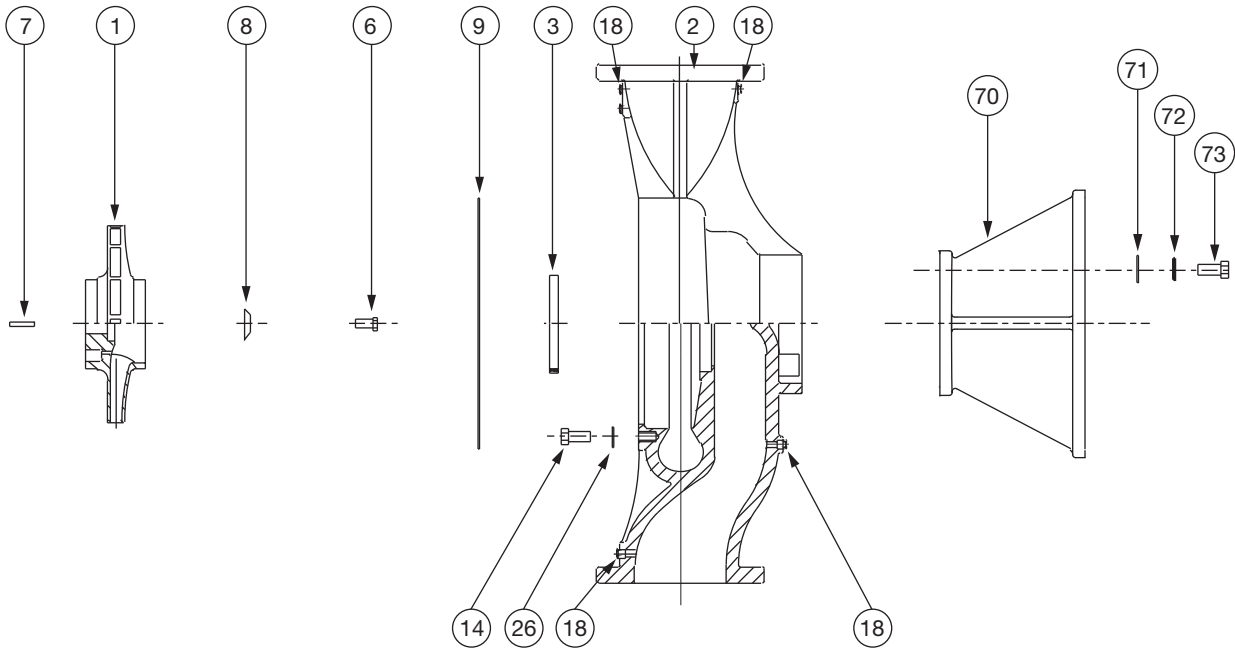
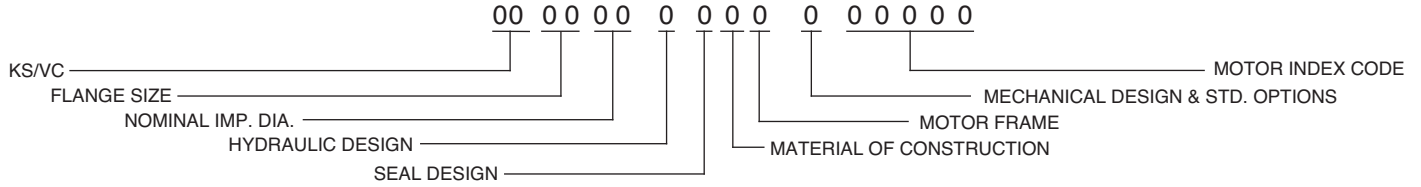

AW-659 REV B

ITEM NO.	NO. REQ.	DESCRIPTION	2011	2011
			FRAME A,B,H OR J	FRAME C,D,E,K,L OR M
1	1	IMPELLER (CI)	953-1097RP	953-1098RP
1	1	IMPELLER (BRZ)	953-1088RP	953-1089RP
2	1	CASING (125#)(W/WR OPT)	953-1092RP	953-1092RP
2	1	CASING (250#)(W/WR OPT)	953-1093RP	953-1093RP
2	1	CASING (125#)(NO WR STD)	953-1445RP	953-1445RP
2	1	CASING (250#)(NO WR STD)	953-1447RP	953-1447RP
3	1(W/R)	WEAR RING (BRZ) (OPT)	953-1095RP	953-1095RP
6	1	IMPELLER BOLT	3/8NCx1"LG	1/2NCx1-1/4LG
7	1	IMPELLER KEY	3/16x3/16x1-1/8LG	1/4x1/4x2LG
8	1	IMPELLER WASHER	953-828RP	953-829RP
9	1	GASKET (CASING)	953-1010RP	953-1010RP
14	12	CASING BOLT	1/2NCx1-1/2LG	1/2NCx1-1/2LG
18	5	PIPE PLUG	1/4 NPT	1/4 NPT
26	12	CASING WASHER	1/2"	1/2"
70	1	SUPPORT STAND (OPTIONAL)	953-3985RP	953-3985RP
71	4	WASHER	1/2"	1/2"
72	4	LOCK WASHER	1/2"	1/2"
73	4	BOLT	1/2"NC x 1 3/8"LG	1/2"NC x 1 3/8"LG

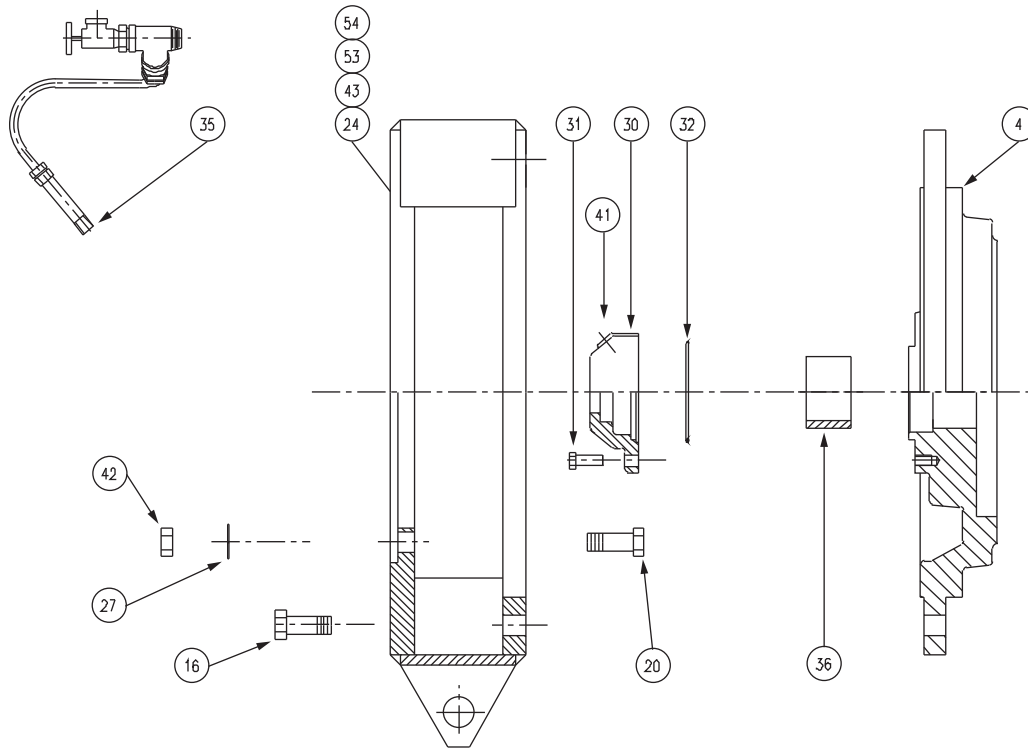

ITEM NO.	NO. REQ.	DESCRIPTION	2011	2011	2011	2011
			FRAME A,H	FRAME B,J	FRAME C,D,K,L	FRAME E,M
4	1	COVER	953-1278RP	953-1278RP	953-1277RP	953-1277RP
16	8	COVER SCREW	3/8NCx2"LG	3/8NCx2"LG	3/8NCx1-1/2LG	3/8NCx1-1/2LG
20	4	MOTOR BOLT *	3/8NCx1-1/2LG	1/2NCx1-3/4LG	1/2NCx1-1/2LG	5/8NCx1-3/4LG
24	1	SUPPORT HEAD	953-1561RP	953-1577RP	953-1559RP	953-1557RP
27	4	MOTOR WASHER *	3/8"	1/2"	1/2"	5/8"
30	1	SEAL CAP (STD)	953-728RP	953-728RP	953-1319RP	953-1319RP
30	1	SEAL CAP (EXTERIOR DES)	953-1323RP	953-1323RP	953-1324RP	953-1324RP
31	2	SEAL CAP SCREW	5/16NCx3/4LG	5/16NCx3/4LG	3/8NCx1LG	3/8NCx1LG
32	1	SEAL CAP GASKET	953-761RP	953-761RP	759-162RP	759-162RP
35	1	TUBE KIT	953-1547RP	953-1547RP	953-1547RP	953-1547RP
36	1	THROTTLE BUSHING	953-1320RP	953-1320RP	953-1321RP	953-1321RP
41	1	SEAL CAP PLUG	1/8NPT	1/8NPT	1/8NPT	1/8NPT
42	4	MOTOR NUT (HP ONLY)	3/8NC	3/8NC	3/8NC	5/8NC
43	1	CPLG GUARD	953-1583RP	953-1583RP	953-1584RP	953-1585RP
53	4	CPLG GUARD SCREW	1/4x3/8LG	1/4x3/8LG	1/4x3/8LG	1/4x3/8LG
54	4	CPLG GUARD WASHER	1/4"	1/4"	1/4"	1/4"

AW-628 REV A

* CZ MOTOR HARDWARE SHOWN ABOVE. FOR HP MOTOR HARDWARE, CONSULT FACTORY

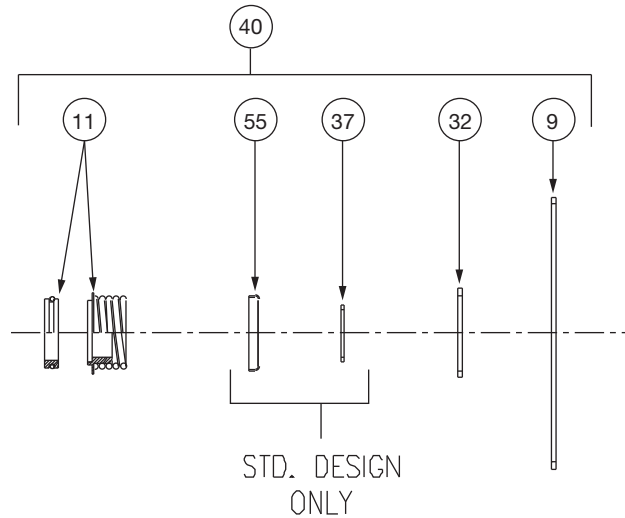

2508, 2510	2508, 2510		2508, 2510	2508, 2510	
1506, 2006, 3006			1506, 2006, 3006		
1507, 2007, 3007, 4007, 4075, 5007 5075	2007, 3007, 4007, 4075, 5007 5075		1507, 2007, 3007, 4007, 4075, 5007 5075	2007, 3007, 4007, 4075, 5007 5075	
1509, 2009, 3009, 4009, 5095, 6009 6095	1509, 2009, 3009, 4009, 5095, 6009 6095		1509, 2009, 3009, 4009, 5095, 6009 6095	1509, 2009, 3009, 4009, 5095, 6009 6095	
2011, 3011, 4011, 6011,	2011, 3011, 4011, 6011, 8011		2011, 3011, 4011, 6011,	2011, 3011, 4011, 6011, 8011	
3013, 4013, 6013	3013, 4013, 6013, 8013, 1013	6013, 8013, 1013	3013, 4013, 6013	3013, 4013, 6013, 8013, 1013	6013, 8013, 1013

ITEM NO.	NO. REQ.	DESCRIPTION	MOTOR FRAME						
			A,B,H OR J	C,D,E,K,L OR M	F OR N	A,B,H OR J	C,D,E,K,L OR M	F OR N	
			MECHANICAL DES. A OR C (125#)			MECHANICAL DES. B OR D (250#)			
9	1	CASING GASKET	SEE PAGE 1	SEE PAGE 1	SEE PAGE 1	SEE PAGE 1	SEE PAGE 1	SEE PAGE 1	STANDARD DESIGN
32	1	SEAL CAP GASKET	953-761	759-162	953-763	953-761	759-162	953-763	
37	1	RETAINING RING	15-147	15-148	15-149	15-147	15-148	15-149	
55	1	SPRINGHOLDER	953-1529RP	953-1530RP	953-1531RP	---	---	---	
11	1	SEAL (TYPE B)	951-3157RP	951-3158RP	951-2966RP	951-3766RP	951-5158RP	951-5151RP	
11	1	SEAL (TYPE D)	951-3159RP	951-3160RP	951-2967RP	951-3781RP	951-5159RP	951-5152RP	
11	1	SEAL (TYPE E)	951-3161RP	951-3162RP	951-2968RP	951-3782RP	951-5160RP	951-5153RP	
40	1	SEAL KIT (TYPE B)	953-1548-1RP	953-1548-4RP	953-1548-7RP	953-1548-10RP	953-1548-13RP	953-1548-16RP	
40	1	SEAL KIT (TYPE D)	953-1548-2RP	953-1548-5RP	953-1548-8RP	953-1548-11RP	953-1548-14RP	953-1548-17RP	
40	1	SEAL KIT (TYPE E)	953-1548-3RP	953-1548-6RP	953-1548-9RP	953-1548-12RP	953-1548-15RP	953-1548-18RP	

9	1	CASING GASKET	SEE PAGE 1	SEE PAGE 1	SEE PAGE 1	EXTERNAL DESIGN		
32	1	SEAL CAP GASKET	953-761	759-162	953-763			
11	1	SEAL (TYPE U)	953-1326RP	953-1327RP	953-1328RP			
11	1	SEAL (TYPE V)	953-1329RP	953-1330RP	953-1331RP			
11	1	SEAL (TYPE W)	953-1332RP	953-1333RP	953-1334RP			
11	1	SEAL KIT (TYPE U)	953-1548-19RP	953-1548-22RP	953-1548-25RP			
11	1	SEAL KIT (TYPE V)	953-1548-20RP	953-1548-23RP	953-1548-26RP			
11	1	SEAL KIT (TYPE W)	953-1548-21RP	953-1548-24RP	953-1548-27RP			

AW-642 REV D

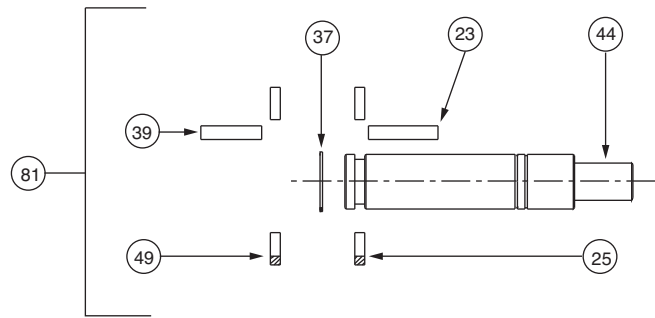
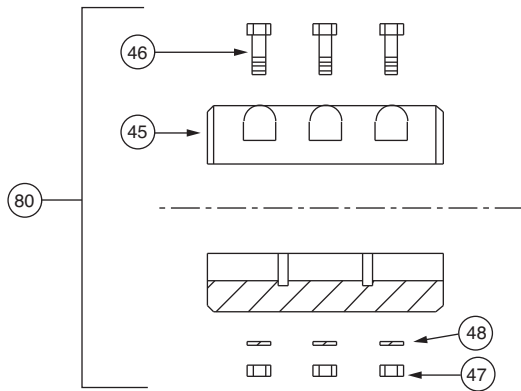

1506	1506	-	-	-
2006	2006	-	-	-
3006	3006	-	-	-
1507	1507	-	-	-
2007	2007	2007	-	-
3007	3007	3007	-	-
4007	4007	4007	4007	-
5007	5007	5007	5007	-
4075	4075	4075	4075	-
5075	5075	5075	5075	-
2508	2508	2508	2508	-
1509	1509	1509	1509	-
2009	2009	2009	-	-
3009	3009	3009	3009	-
4009	4009	4009	4009	-
-	6009	6009	6009	-
-	5095	5095	-	-
-	6095	6095	6095	-
-	2510	2510	-	-
2011	2011	-	-	-
3011	3011	3011	-	-
-	4011	4011	-	-
-	6011	6011	6011	-
-	8011	8011	8011	-
-	3013	3013	-	-
-	4013	4013	-	-
-	6013	6013	6013	6013
-	-	8013	8013	8013
-	-	1013	1013	1013

ITEM NO.	NO. REQ.	DESCRIPTION	FRAME: A, H	FRAME: B, J	FRAME: C,D,K,L	FRAME: E, M	FRAME: F, N
45	1	COUPLING	953-1311RP	951-202RP	953-1310RP	953-1309RP	953-1527RP
46	6	BOLT-COUPLING	5/16 x 2LG	5/16 x 2LG	5/16 x 2LG	5/16 x 2LG	5/16 x 2-1/2LG
47	6	NUT-COUPLING	5/16	5/16	5/16	5/16	5/16
48	6	LOCK WASHER-COUPLING	5/16	5/16	5/16	5/16	5/16
80	1	COUPLING KIT	953-1603RP	953-1604RP	953-1605RP	953-1606RP	953-1607RP
44	1	SHAFT	953-1298RP	953-1298RP	953-1297RP	953-1297RP	953-1296RP
44	1	**SHAFT FOR 1013 ONLY	---	---	953-2036RP	953-2036RP	953-2037RP
25	1	CIRCULAR KEY-PUMP	953-1313RP	953-1313RP	953-1314RP	953-1314RP	953-1316RP
49	1	CIRCULAR KEY-MOTOR	953-1312RP	953-1313RP	953-1313RP	953-1315RP	953-1315RP
23	1	KEY-PUMP	1/4x1/4x1-1/4LG	1/4x1/4x1-1/4LG	3/8x3/8x1-1/2LG	3/8x3/8x3LG	1/2x1/2x3LG
39	1	KEY-MOTOR	3/16x3/16x1-1/4LG	1/4x1/4x1-1/4LG	1/4x1/4x1-1/4LG	3/8x3/8x3LG	3/8x3/8x3LG
37	1	RETAINING RING-SEAL	1 1/8	1 1/8	1 1/2	1 1/2	1 7/8
81	1	SHAFT KIT	953-1608RP	953-1609RP	953-1610RP	953-1611RP	953-1612RP
81	1	*SHAFT KIT FOR 1013 ONLY	---	---	953-2129RP	953-2130RP	953-2131RP

AW-643 REV D

Do it Once. Do it Right.®

TACO, INC., 1160 Cranston Street, Cranston, RI 02920 Telephone: (401) 942-8000 FAX: (401) 942-2360.
TACO (Canada), Ltd., 8450 Lawson Road, Unit #3, Milton, Ontario L9T 0J8. Telephone: 905/564-9422. FAX: 905/564-9436.

Visit our web site at: <http://www.taco-hvac.com>

Printed in USA
 Copyright 2009
 TACO, Inc.