

James Electric

Domestic Cold Water Pressure Booster Packages



Custom Package Shown

- *Duplex and Triplex Standard Configurations*
- *Vertical Pump Configuration Minimizes Footprint*
- *Factory Tested*
- *CSA Approved Control Panel*
- *Breakaway Flanges to Allow for Future Repairs*
- *Each Package is Custom Manufactured to Meet the Building Requirements and the Piping Footprint*
- *Available for 125 # or 250 # Applications*

Construction Features

- Fabricated welded steel frame assembly
- Pumps designed and assembled specifically for each application
- Copper suction header with vic groove
- Copper discharge header with vic groove
- Bronze full port ball valves on each pump (suction and discharge)
- Epoxy coated Cla-Val pressure reducing valves (one for each pump)
- 4" Liquid filled pressure gauges on suction and discharge c/w isolating valves
- Liquid-Tite flexible conduit wiring to both pumps
- Stainless steel interconnecting piping
- Thermal relief or thermal shut-down circuit (depending on building requirements)

Optional Features

- NEMA 4 or 12 enclosure
- Low suction pressure alarm c/w dry contacts and terminals
- No-flow shutdown c/w dry contacts and terminals
- Pump Run c/w dry contact with terminals
- Pump overload trip c/w dry contacts and terminals
- Door mounted overload resets
- Thermal shutdown via aquastat (dry contacts optional)
- Thermal shutdown will also require a drawdown tank

Control Panel Features

- CSA NEMA 1 enclosure
- Main disconnect interlocked with door
- Thermo-magnetic motor protection
- "Power On" lamp
- "Pump Run" lamps
- "Hand-Off-Auto" switch for each pump
- Low suction pressure switch
- Low suction pressure warning lamp
- Thermal relief circuit
- Terminal strip connections for all external devices
- Starters with field adjustable 3-leg overload protection
- Control transformer with fused primary and secondary
- Programmable logic controller (PLC Programming)
 - Electric current pump sequencing (via on and off time delay timers)
 - Automatic weekly pump alternation c/w a 5 second "off delay" during the pump transition
 - Automatic start-up of the standby pump should the lead pump fail
 - Automatic start-up of the standby pump should the lead pump be unable to keep up to demand
- CSA approved

DUPLEX DIMENSIONS

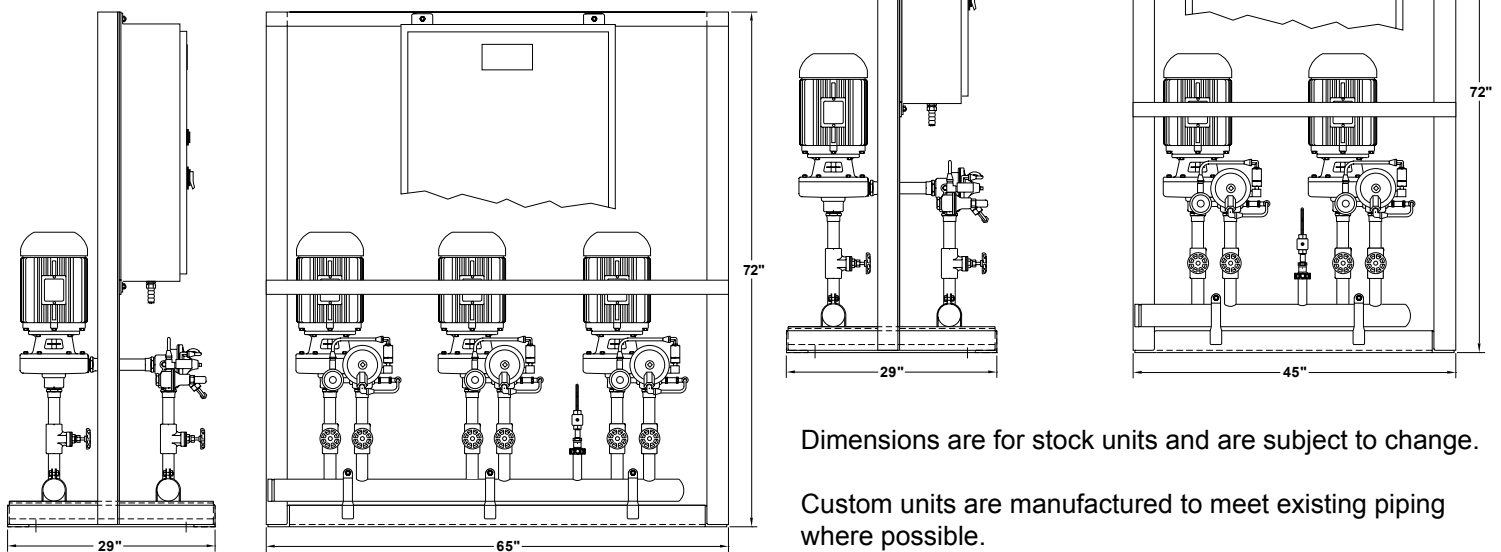

Dimensions are for stock units and are subject to change.

Custom units are manufactured to meet existing piping where possible.

James Electric

4020 - 8 Street SE Calgary, Alberta, T2G 3A7

Phone: 403-252-5477 Fax: 403-253-8026 Toll Free: 1800-465-3027

Email: motors@jameselectric.ca Web: www.jameselectric.ca