

# MYERS® HC and HCM Series Convertible Jet Pumps

Myers® convertible jet pumps provide all the water and pressure needed for today's family living needs. High quality materials and simplified construction combine for excellent performance in shallow and deep wells. The same twin ejector is used for both types of well service.

## APPLICATIONS

■ **Water systems and sprinkling...** for homes, farms and industry

## SPECIFICATIONS

**Motor** – 2-Compartment 115/230 Volt

**Rotary Seal** – Stainless Steel/  
Buna N

**Impeller** – Brass

**Motor Bracket** – Cast iron

**Discharge Diffuser** – Cast iron

**Second Stage Diffuser (HCM's)** –  
Cast iron

**Diffuser Housing** – Cast iron

**Motor Shaft** – Stainless Steel

**Pressure Switch** – Square  
D dual adjustment



## FEATURES

**Heavy Duty Cast Iron Case Construction**

**Primes Easily** – Under maximum shallow well conditions

**Brass Impeller** – Balanced for smooth operation

**Fast Connect Flanges** – Eliminates threading and fitting at pipe end

**Stream-flo Design** – Provides optimum hydraulic performance

**Durable Cast Iron Pressure Regulator Included**

**Pressure Switch and Pressure Gauge Included**

## ORDERING INFORMATION

Catalog Number	Discharge	Pressure Switch Setting	Packer Type Inner Pipe Size for 2" Well	Twin Type Drop Pipe Size	Foot Valve Size - Twin Type Only	Motor Capacitor Type Built-in Overload Protection	Shipping Wt. Pump Unit Only	Shipping Weight Jet Packages for		
								4" Well		2" Well
								Bronze	Cast Iron	
<b>HC50</b>										
HC50	3/4"	20-40	1"	1-1/4" x 1"	1-1/4"	115/230 volt	54	5	4	4
<b>HCM</b>										
HCM50	3/4"	30-50	1"	1-1/4" x 1"	1-1/4"	115/230 volt	57	5	4	4
HCM100	1"	40-60	1"	1-1/4" x 1-1/4"	1-1/4"	115/230 volt	78	5	4	4
HCM150	1"	40-60	1"	1-1/4" x 1-1/4"	1-1/4"	115/230 volt	85	5	4	4

# MYERS® HC and HCM Series Convertible Jet Pumps

<b>PUMP PERFORMANCE – HC50 SHALLOW WELL</b>																	
Catalog Number	HP	Jet Package Cat. No.	5 Foot Suction Lift					15 Foot Suction Lift					20 Foot Suction Lift				
			Discharge Pressure, PSI					Discharge Pressure, PSI					Discharge Pressure, PSI				
			20	30	40	50	60	20	30	40	50	60	20	30	40	50	60
			Capacity in U.S. Gallons per Minute														
HC50	1/2	SW50	13.5	13	11.5	10	6.6	10	10	9.3	8	4.6	5.5	5.5	5.5	5	2

<b>PUMP PERFORMANCE – HC50 DEEP WELL</b>																	
Catalog Number	HP	Max. Amps 115/230 V	Average Regulator Setting	Jet Package Cat. No.			Vertical Distance in Feet from Pump to Low Water Level										
				Twin Type		Packer	30	40	50	60	70	80	90	100	110		
				4" Min. Well		2" Well	Capacity in U.S. Gallons per Minute										
				Cast Iron	Bronze												
HC50	1/2	10.6 / 5.3	22 PSI	DW50-I	DW-50	P50	12	11	9.8	8.3	6.5	4.5	2.3				

<b>PUMP PERFORMANCE – HCM SHALLOW WELL</b>																				
Catalog Number	HP	Jet Package Cat. No.	5 Foot Suction Lift						15 Foot Suction Lift						20 Foot Suction Lift					
			Discharge Pressure, PSI						Discharge Pressure, PSI						Discharge Pressure, PSI					
			30	40	50	60	70	80	30	40	50	60	70	80	30	40	50	60	70	80
			Capacity in U.S. Gallons per Minute																	
HCM50	1/2	SW50	10.5	10	9.5	9	4		8	8	7.5	7	3.5		6.5	6.5	5.5	5.5	2	
HCM100	1	SW100	19	19	16.5	16	13	10	13	13	13	12	10	8	8	8	8	8	8	6.5
HCM150	1-1/2	SW150	22.5	22.5	22.5	20	20	13	17	17	16.5	16	14	11	9.3	9.3	9.3	9.3	8.8	8.3

<b>PUMP PERFORMANCE – HCM DEEP WELL</b>																				
Catalog Number	HP	Max. Amps 115/230 V	Average Regulator Setting	Jet Package Cat. No.			Vertical Distance in Feet from Pump to Low Water Level													
				Twin Type		Packer	30	40	50	60	70	80	90	100	110	120	130	140	150	
				4" Min. Well		2" Well	Capacity in U.S. Gallons per Minute													
				Cast Iron	Bronze															
HCM50	1/2	10.6 / 5.3	22 PSI	DW50-I	DW50	P50	11.5	9.5	8	6.5	6.5	4	3	2	1					
HCM100	1	17.0 / 8.5	34 PSI	DW100-I	DW100	P100	15	13.3	12	10.6	9.3	8	6.6	5.3	4	2.6	2			
HCM150	1-1/2	19.8 / 9.9	40 PSI	DW150-I	DW150	P150	17.5	16	14.5	12.8	11.6	9.5	8	7	6	5	4	3	2	

# MYERS® HC and HCM Series Convertible Jet Pumps

## PUMP PERFORMANCE

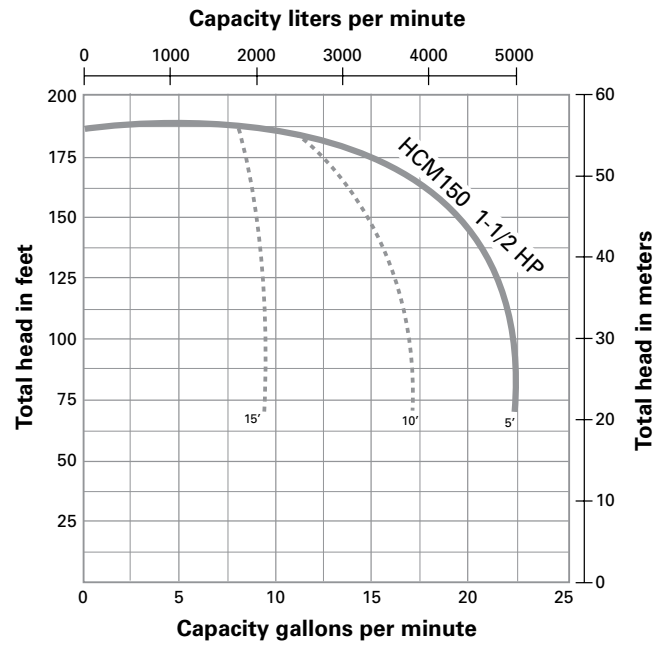
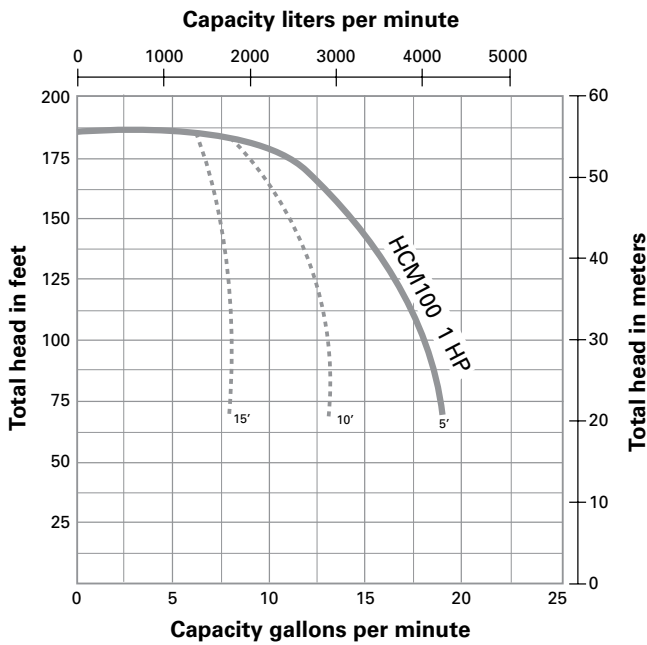
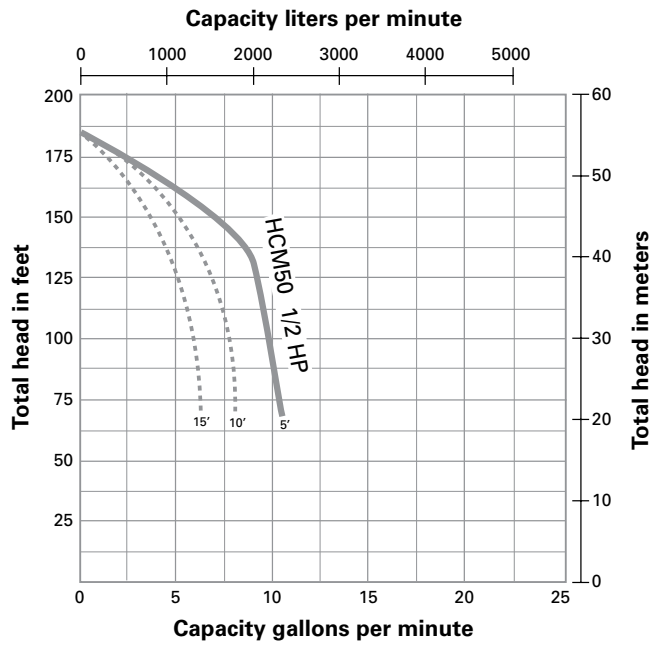
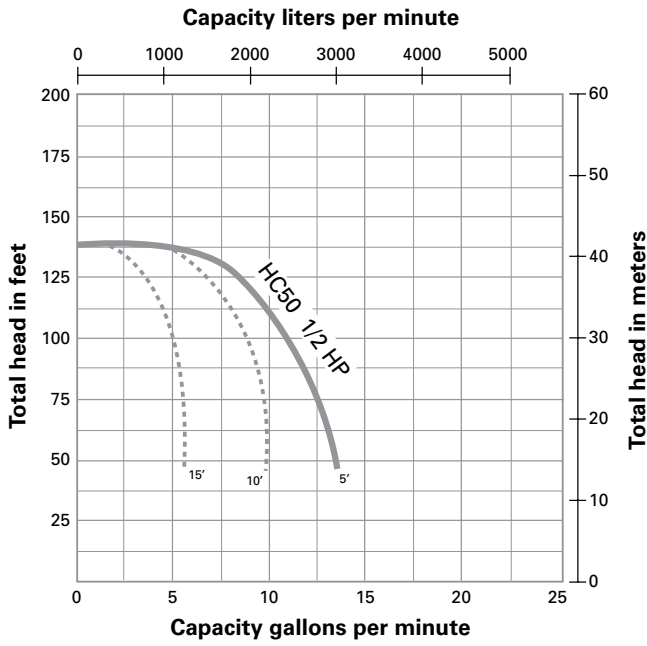

# MYERS® HC and HCM Series Convertible Jet Pumps

## OUTLINE DIMENSIONS

### HC50 AND HCM50

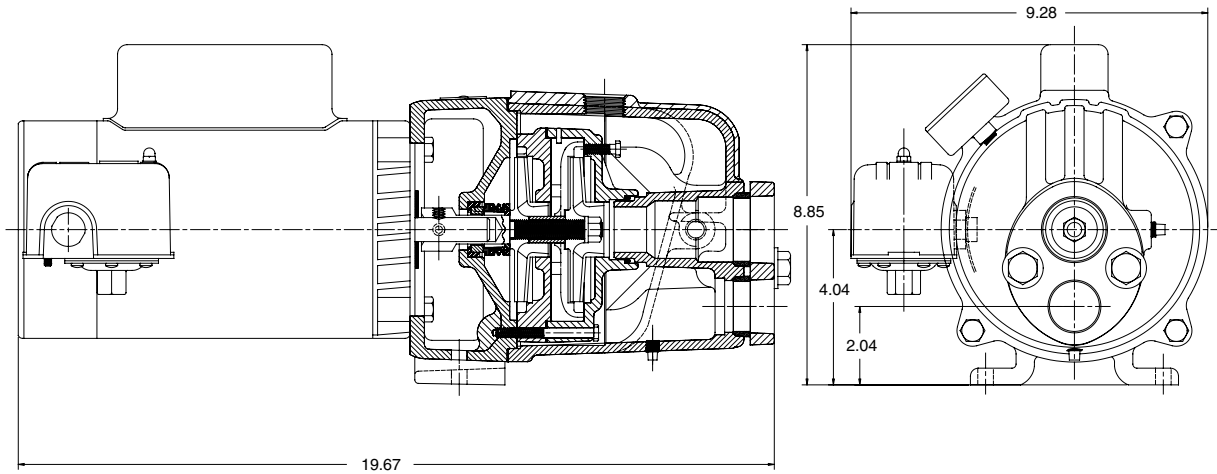

### HCM100 AND HCM150

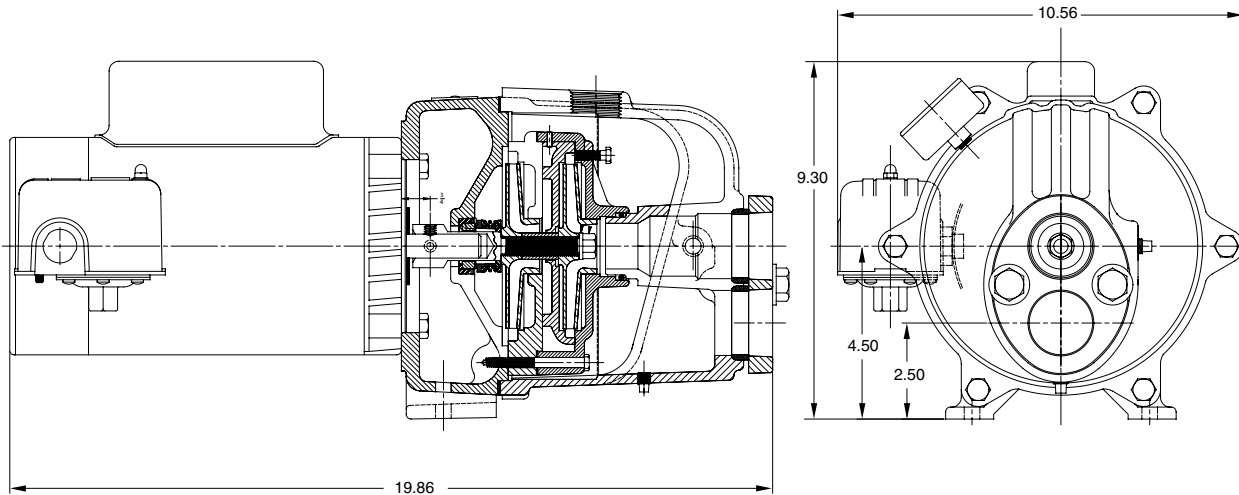

Dimensions (in inches) are for estimating purposes only.



USA 293 WRIGHT STREET, DELAVAN, WI 53115 WWW.FEMYERS.COM PH: 888-987-8677 ORDERS FAX: 800-426-9446  
CANADA 490 PINEBUSH ROAD, UNIT 4, CAMBRIDGE, ONTARIO, N1T 0A5 PH: 800-363-7867 ORDERS FAX: 888-606-5484  
Because we are continuously improving our products and services, Pentair reserves the right to change specifications without prior notice.