

MODEL HD50C

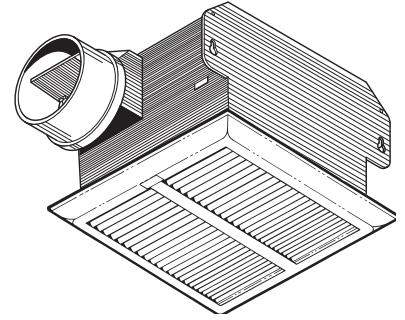

HEAVY DUTY CEILING/WALL FAN



Quiet heavy duty ceiling/wall fan built with high performance blower, attractive metal grille.

FEATURES

GRILLE:

- Attractive metal grille finished with white acrylic paint
- Conceals interior
- Low profile blends well with any decor
- Torsion spring grille mounting - no tools required

BLOWER:

- Plug-in, permanently lubricated, totally enclosed motor
- Centrifugal blower wheel for quiet, efficient performance
- Long life motor bearings
- Designed for continuous operation

HOUSING:

- Rugged 26-gage galvanized steel construction
- Integral key-holed mounting brackets for easy, secure installation directly to joist
- Provision for wire suspension when installed in a drop ceiling
- Tapered, polymeric duct fitting with built-in backdraft damper for easy, positive duct connection and no metallic clatter

U.L. Listed for use over bathtubs and showers when connected to a GFCI protected branch wiring.

TYPICAL SPECIFICATION

Ceiling/wall fan shall be Broan Model HD50C.

Ceiling/wall fan shall have galvanized steel housing with integral mounting brackets. Ceiling/wall fan shall have built-in backdraft damper and shall be ducted to a roof or wall cap.

Motor to be totally enclosed, permanently lubricated, and have long-life bearings designed for continuous operation. Blower assembly shall have a centrifugal blower wheel and be removable from housing.

Air delivery shall be no less and sound level no greater than valves listed in the "Performance Ratings" charts on this sheet. All air and sound ratings shall be certified by HVI and AMCA licensed.

Ceiling/wall fan shall be U.L. Listed for use over bathtubs and showers when connected to a GFCI protected branch circuit.

Ceiling/wall fan shall be Energy Star® qualified.



Broan-NuTone Canada certifies that the model shown herein is licensed to bear the AMCA Seal. The ratings shown are based on tests and procedures performed in accordance with AMCA Publication 211 and AMCA Publication 311 and comply with the requirements of the AMCA Certified Ratings Program.



Broan-NuTone Canada; Mississauga, Ontario www.broan.ca 877-896-1119

REFERENCE	QTY.	REMARKS	Project
			Location
			Architect
			Engineer
			Contractor
			Submitted by Date

PERFORMANCE RATINGS - MODEL HD50C

AMCA LICENSED PERFORMANCE

Model No.		Static Pressure (in. wg Ps)					Volts	Watts	RPM	Nominal Duct Size
		0.0	0.1	.125	.250	.375				
HD50C	CFM	61	51	48	31	9	120	30	1070	4" Round
	Sones	1.9	2.2	2.3	3.0	3.3				

The performance ratings include the effects of inlet grille and backdraft damper in the airstream. Speed (RPM) shown is nominal. Performance is based on actual speed of test. The sound ratings are loudness values in fan sones at 5' (1.5m) in a hemispherical free field calculated per AMCA Std. 301. Values shown are for Installation Type B: Free inlet fan sone levels. Air performance shown is for Installation Type B: Free inlet, Ducted outlet.

SONES

Model Number	HVI Sones @ 0.1" Ps*	AMCA Sones @ 0.0" Ps*
HD50C	1.5	1.9

*There is a difference between sone values certified by HVI for residential use and by AMCA for commercial/industrial use. Exact comparison of these values is not possible. This difference is mainly due to the procedures used to convert measured sound to perceived sound. ANSI S3.4, used by both HVI and AMCA, specifies a procedure for calculating loudness as perceived by a typical listener under specific conditions. HVI establishes values at a distance of 5 feet from the fan in a "spherical free field"; AMCA establishes values at a distance of 5 feet in a "hemispherical free field". HVI and AMCA have different rules for rounding sone values.

AMPS

MODEL NUMBER	AMPS
HD50C	0.4



Broan-NuTone Canada certifies that the model shown herein is licensed to bear the AMCA Seal. The ratings shown are based on tests and procedures performed in accordance with AMCA Publication 211 and AMCA Publication 311 and comply with the requirements of the AMCA Certified Ratings Program.

HVI PERFORMANCE

MODEL NUMBER	SONES	CFM @0.1" Ps
HD50C	1.5	50



HVI-2100 CERTIFIED RATINGS comply with new testing technologies and procedures prescribed by the Home Ventilating Institute, for off-the-shelf products, as they are available to consumers. Product performance is rated at 0.1 in. static pressure, based on tests conducted in a state-of-the-art test laboratory. Sones are a measure of humanly-perceived loudness, based on laboratory measurements.

WEIGHT

MODEL NO.	SHIPPING WT.
HD50C	7.1 lb

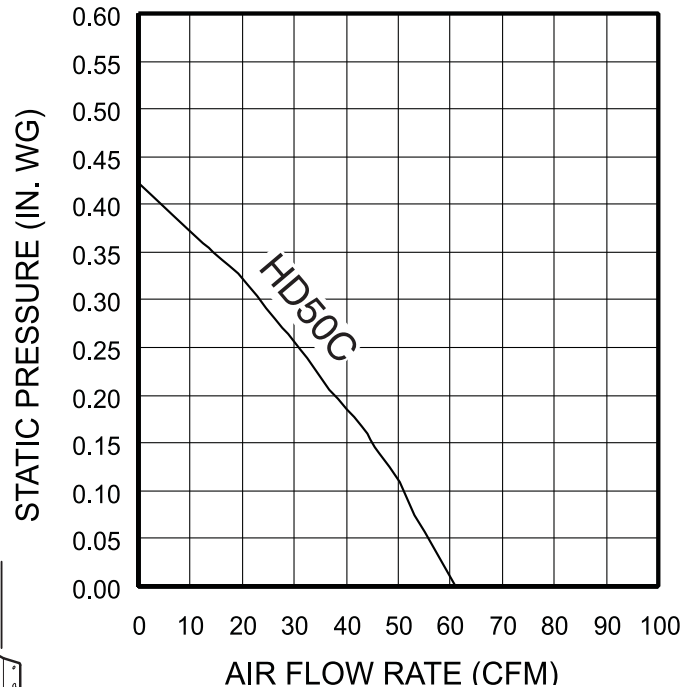
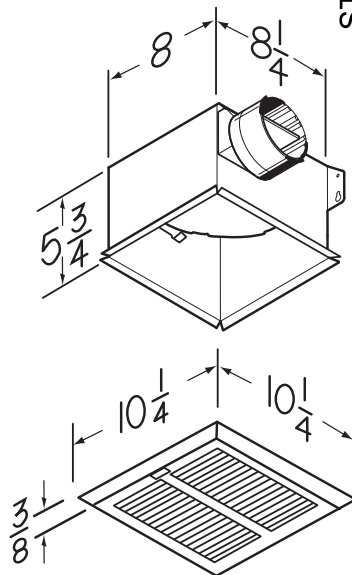

NOTE: Dimensions are in inches.

