

## E.2 SERIES CIRCULATORS

### E8.2/E8.2B | SUBMITTAL

File No: 10.591  
 Date: JUNE 25, 2012  
 Supersedes: 10.591  
 Date: MARCH 15, 2012

Job: \_\_\_\_\_ Representative: \_\_\_\_\_  
 \_\_\_\_\_ Order no.: \_\_\_\_\_ Date: \_\_\_\_\_  
 Engineer: \_\_\_\_\_ Submitted by: \_\_\_\_\_ Date: \_\_\_\_\_  
 Contractor: \_\_\_\_\_ Approved by: \_\_\_\_\_ Date: \_\_\_\_\_

QUANTITY	TAG NO.	PART NUMBER	FLOW (USgpm)	HEAD (FEET)	VOLTAGE	PHASE	COMMENTS

#### TECHNICAL DATA

**Flow range:** 0 to 38.0 USgpm (0 to 2.4 L/s)  
**Head range:** 0 to 34.0 feet (0 to 10.4 m)  
**Max/Min fluid temp:** 230°F/40°F (110°C/4°C)  
**Max. working pressure:** 150 psi (1034 kPa)

#### MATERIALS OF CONSTRUCTION

**Pump body:** Cast iron (closed systems)  
 Bronze (lead free for open systems)

**Face plate:** Stainless steel      **Shaft:** Stainless steel  
**Impeller:** 30% Glass-filled noryl      **Volute gasket:** EPDM  
**Bearings:** Permanently lubricated stainless steel  
**Seal:** Silicon carbide enviroseal c/w viton elastomer

#### PART NUMBER

	120V	240V
<b>E8.2</b>	182202-657	182202-645
<b>E8.2B</b>	182202-658	182202-646

#### E8.2/E8.2B ACCESSORIES

- ¾" Flange kits
- 1" Flange kits
- 1¼" Flange kits
- 1½" Flange kits
- Timer
- Aquastat
- Spool pieces

#### MOTOR DATA

Voltage	120V	208V	240V
<b>Full load amp draw</b>	2.0A	1.0A	1.0A
<b>Nominal power:</b> ¼ hp (125W)	<b>Frequency:</b> 60 Hz		
<b>Motor type:</b> Two pole, Single phase	<b>Speed:</b> 3400 rpm		

#### MOUNTING ORIENTATION FOR INDOOR USE ONLY

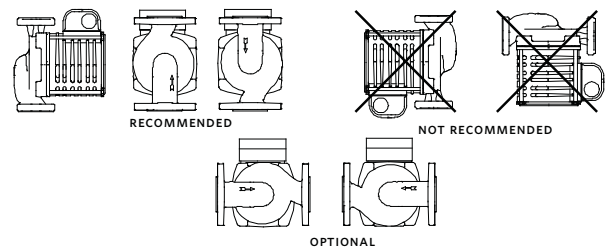

#### PERFORMANCE CURVE

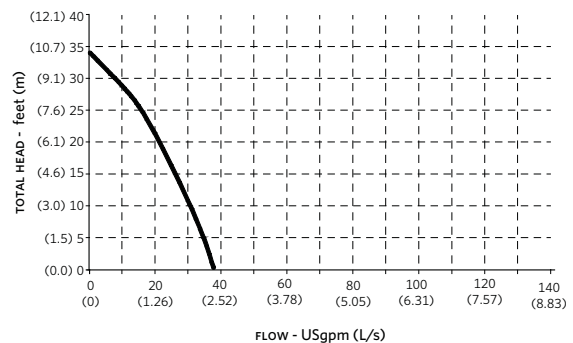

Performance curves are for reference only. Confirm current performance data with Armstrong ACE ONLINE selection software.

DIMENSIONS inches (mm)								SHIP. WEIGHT	
MODEL	BODY	A	B	C	D	E	F	CONNECTION TYPE & SIZE	lbs (kgs)
E8.2	Cast iron	7.10 (180)	6.40 (164)	5.50 (140)	3.80 (97)	3.20 (81)	4.20 (107)	1.25" diameter 2-bolt flanges	13.1 (5.94)
E8.2B	Bronze	7.10 (180)	6.40 (164)	5.50 (140)	3.80 (97)	3.20 (81)	4.20 (107)	1.25" diameter 2-bolt flanges	13.3 (6.03)

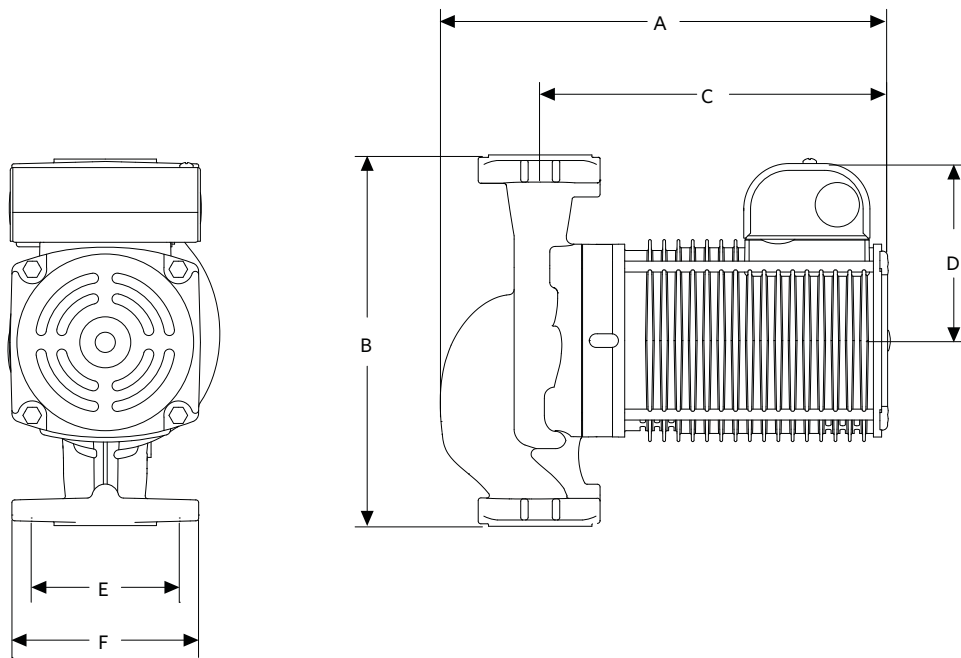

**TORONTO**

+416 755 2291

**BUFFALO**

+716 693 8813

**BIRMINGHAM**

+44 (0) 8444 145 145

**MANCHESTER**

+44 (0) 8444 145 145

**BANGALORE**

+91 (0) 80 4906 3555

**SHANGHAI**

+86 21 3756 6696