

Dimensions

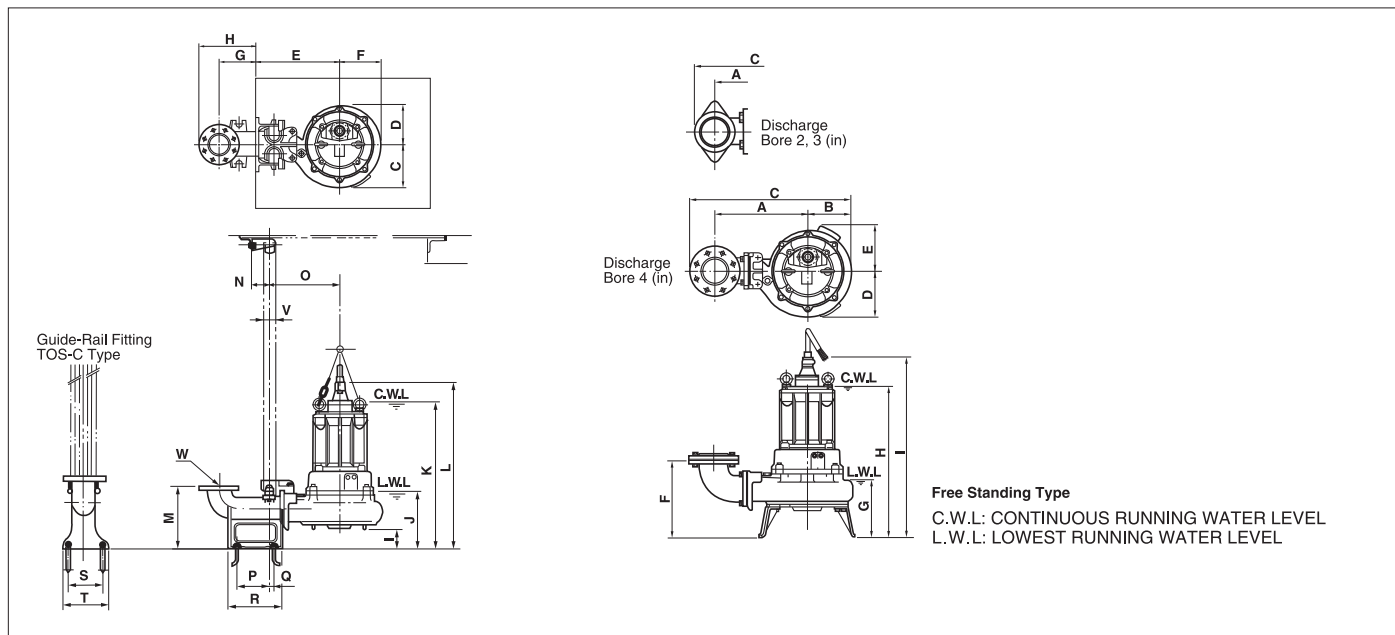

Guide-Rail Fitting TOS-C Type

UNIT: in.

Discharge Bore (in.)	Model	C	D	E	F	G	H	I	J	K	L	M	N	O	P	Q	R	S	T	V	W
2	TOS50C2.75	4 7/8	4 7/8	9 5/8	4 7/8	6 7/8	10 (10 3/8)	1 3/4	7 1/2	16 1/2	18	9 7/8	2	7 5/8	4 3/8	3/8	7 7/8	4 3/4	6 1/4	1	2 (2 1/2)
3	TOS80C21.5	4 7/8	4 7/8	11 1/4	4 7/8	6 1/2	10 1/8 (10)	2	9 1/2	20 1/4	23 1/8	11 3/8	2 3/8	8 7/8	6 1/8	5/8	9 7/8	6 3/4	8 5/8	1 1/4	3 (2 1/2)
4 (3)	TOS100C42.2	6 5/8	6 1/2	13	6 1/8	6 1/2	10 5/8 (10 1/8)	5/8	9 1/2	23	24 7/8	11 3/8	2 3/8	10 5/8	6 1/8	5/8	9 7/8	6 3/4	8 5/8	1 1/4	4 (3)
	TOS100C43.7	6 7/8	6 1/2	13	6 1/4	6 1/2	10 5/8 (10 1/8)	3/8	9 5/8	25 3/4	27 1/2	11 3/8	2 3/8	10 5/8	6 1/8	5/8	9 7/8	6 3/4	8 5/8	1 1/4	4 (3)
	TOS100C45.5	8	7 1/8	16 3/4	7 5/8	7 1/8	11 1/4 (10 3/4)	4 5/8	12	30 1/2	35 5/8	13 3/8	3 3/4	13	7 1/8	3/4	11 3/8	7 7/8	9 7/8	2	4 (3)
	TOS100C47.5	8	7 1/8	16 3/4	7 5/8	7 1/8	11 1/4 (10 3/4)	4 5/8	12	31 1/2	36 1/2	13 3/8	3 3/4	13	7 1/8	3/4	11 3/8	7 7/8	9 7/8	2	4 (3)
	TOS100C411	9 1/8	7 7/8	16 3/4	8 1/2	7 1/8	11 1/4 (10 3/4)	4 5/8	11 3/4	33 1/8	39 1/4	13 3/8	3 3/4	13	7 1/8	3/4	11 3/8	7 7/8	9 7/8	2	4 (3)
	TOS100C415	9 1/8	7 5/8	16 3/4	8 1/2	7 1/8	11 1/4	5	13 1/4	36 1/4	42 1/2	13 3/8	3 3/4	13	7 1/8	3/4	11 3/8	7 7/8	9 7/8	2	4
High Head 3	80C22.2	5 3/16	5 1/16	12 3/16	4 15/16	6 1/2	10 (10 3/16)	1 1/8	9 1/2	23 3/8	25 3/16	11 7/16	N/A	9 13/16	6 11/16	1 9/16	9 13/16	6 11/16	8 11/16	2 3/8	N/A
	80C23.7	5 3/16	5 1/16	12 3/16	4 15/16	6 1/2	10 (10 3/16)	1 1/8	9 1/2	23 3/8	25 3/16	11 7/16	N/A	9 13/16	6 11/16	1 9/16	9 13/16	6 11/16	8 11/16	2 3/8	N/A
	80C25.5	7 1/16	5 9/16	14 9/16	6 5/16	6 1/2	10 (10 3/16)	5	9 5/8	29 3/8	35 1/2	11 7/16	N/A	12 3/16	6 11/16	1 9/16	9 13/16	6 11/16	8 11/16	2 3/8	N/A
	80C27.5	7 1/16	5 9/16	14 9/16	6 5/16	6 1/2	10 (10 3/16)	5	9 5/8	29 3/8	35 1/2	11 7/16	N/A	12 3/16	6 11/16	1 9/16	9 13/16	6 11/16	8 11/16	2 3/8	N/A
	80C211	5 9/16	7 1/16	14 9/16	6 5/16	6 1/2	10 (10 3/16)	5	9 5/8	30 1/8	36 7/16	11 7/16	N/A	12 3/16	7 1/8	1 9/16	9 13/16	6 11/16	8 11/16	2 3/8	N/A

Free Standing Type

UNIT: in.

Discharge Bore (in.)	Model	A	B	C	D	E	F	G	H	I
2	50C2.75	8 7/8	4 7/8	16	4 7/8	4 7/8	7 3/4	5 3/4	14 3/4	16 1/4
3	80C21.5	10 1/2	4 7/8	17 1/2	4 7/8	4 7/8	9 1/4	7 1/2	18 1/4	21 1/8
4 (3)	100C42.2	13 1/4 (12 5/8)	6 1/8	23 1/2 (22 3/8)	6 5/8	6 1/2	12 7/8 (11 7/8)	8 7/8	22 1/2	24 1/4
	100C43.7	13 1/4 (12 5/8)	6 1/4	23 3/4 (22 5/8)	6 7/8	6 1/2	13 1/8 (12 1/8)	9 1/4	25 3/8	27 1/8
	100C45.5	15 1/4 (14 1/4)	7 5/8	27 (25 5/8)	8 1/8	8 1/8	14 5/8 (13 5/8)	13 1/4	30 1/2	35 3/4
	100C47.5	15 1/4 (14 1/4)	7 5/8	27 (25 5/8)	8 1/8	8 1/8	14 5/8 (13 5/8)	13 1/4	31 1/2	36 5/8
	100C411	15 1/4	8 1/2	28	9 1/8	7 7/8	14 5/8	11 3/4	33 1/8	39 3/8
	100C415	15 1/4	8 1/2	27 7/8	9 1/8	8 1/8	14 5/8	13 1/4	36 1/4	42 1/2
High Head 3	80C22.2	11 7/8	4 15/16	20 7/16	5 3/16	5 1/16	11 3/8	8 1/4	22 1/4	24 1/16
	80C23.7	11 7/8	4 15/16	20 7/16	5 3/16	5 1/16	11 3/8	8 1/4	22 1/4	24 1/16
	80C25.5	14 1/4	6 5/16	24 3/16	7 1/16	6 9/16	12 5/8	9 5/8	29 3/8	34 5/8
	80C27.5	14 1/4	6 5/16	24 3/16	7 1/16	6 9/16	12 5/8	9 5/8	29 3/8	34 5/8
	80C211	14 1/4	6 5/16	24 3/16	6 9/16	7 1/16	12 5/8	9 5/8	30 1/8	36 1/2

We reserve the right to change specifications and designs herein for improvement without prior notice.

TSURUMI (AMERICA), INC.

1625 Fullerton Court, Glendale Heights, IL 60139
 Phone (630) 793-0127 Fax (630) 793-0146
 1-888-TSURUMI (8787864)
 info@tsurumiamerica.com

Your Dealer



C Series

CUTTER TYPE SEWAGE & WASTERWATER PUMPS

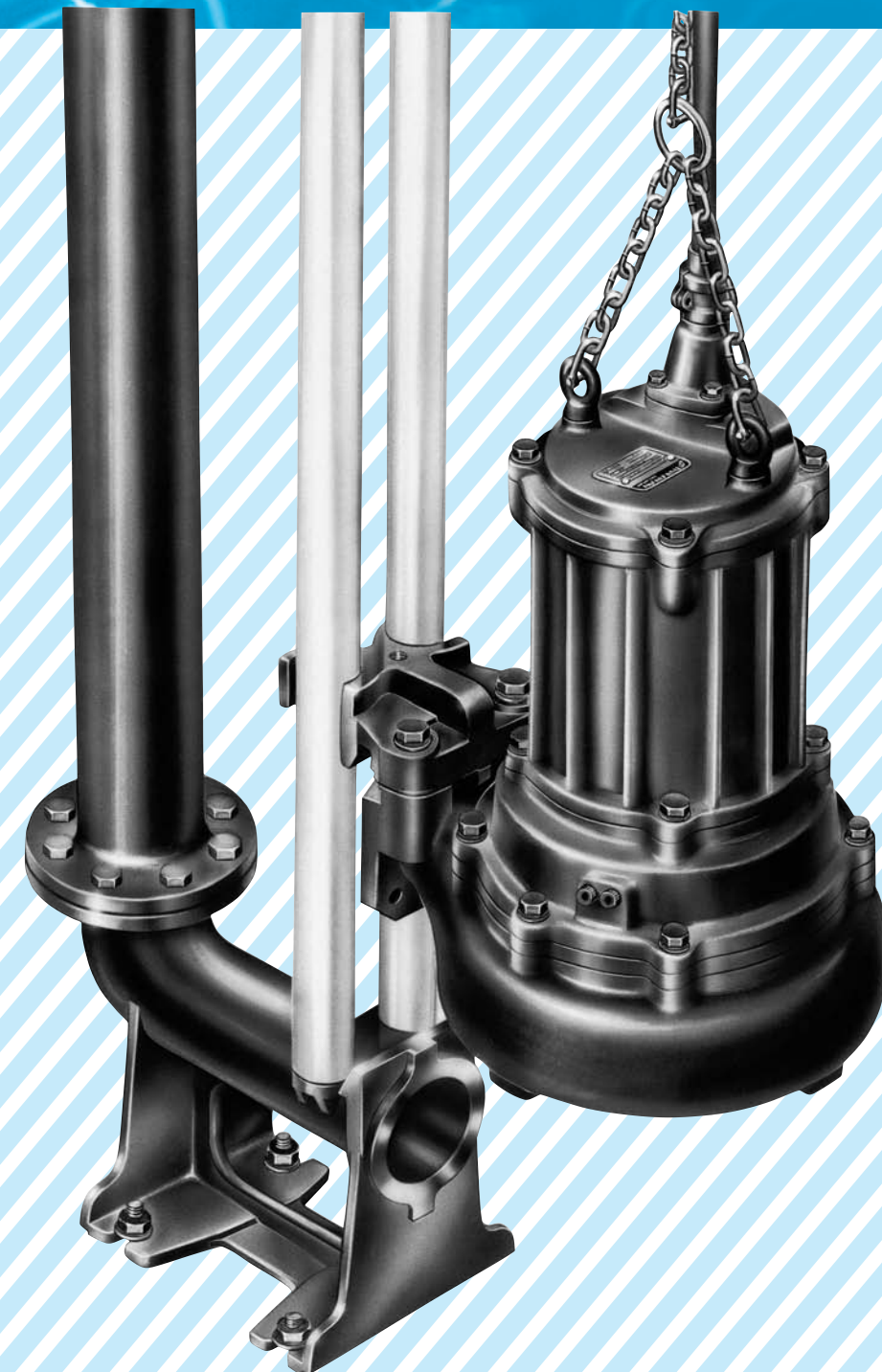

Tungsten Carbide Edged Impeller Shreds Solids, Making Pumps Efficient Sewage Ejectors

TSURUMI C-series submersible pumps with a tungsten carbide edged impeller are ideal for pumping sewage, waste water, and digested solids containing long fibers materials at pumping stations and sewage treatment plants. The pumps are also used at many construction sites for continuous drainage. The C-series pumps have the same high-quality construction as the B-series. See our B-series catalogue for typical installation.

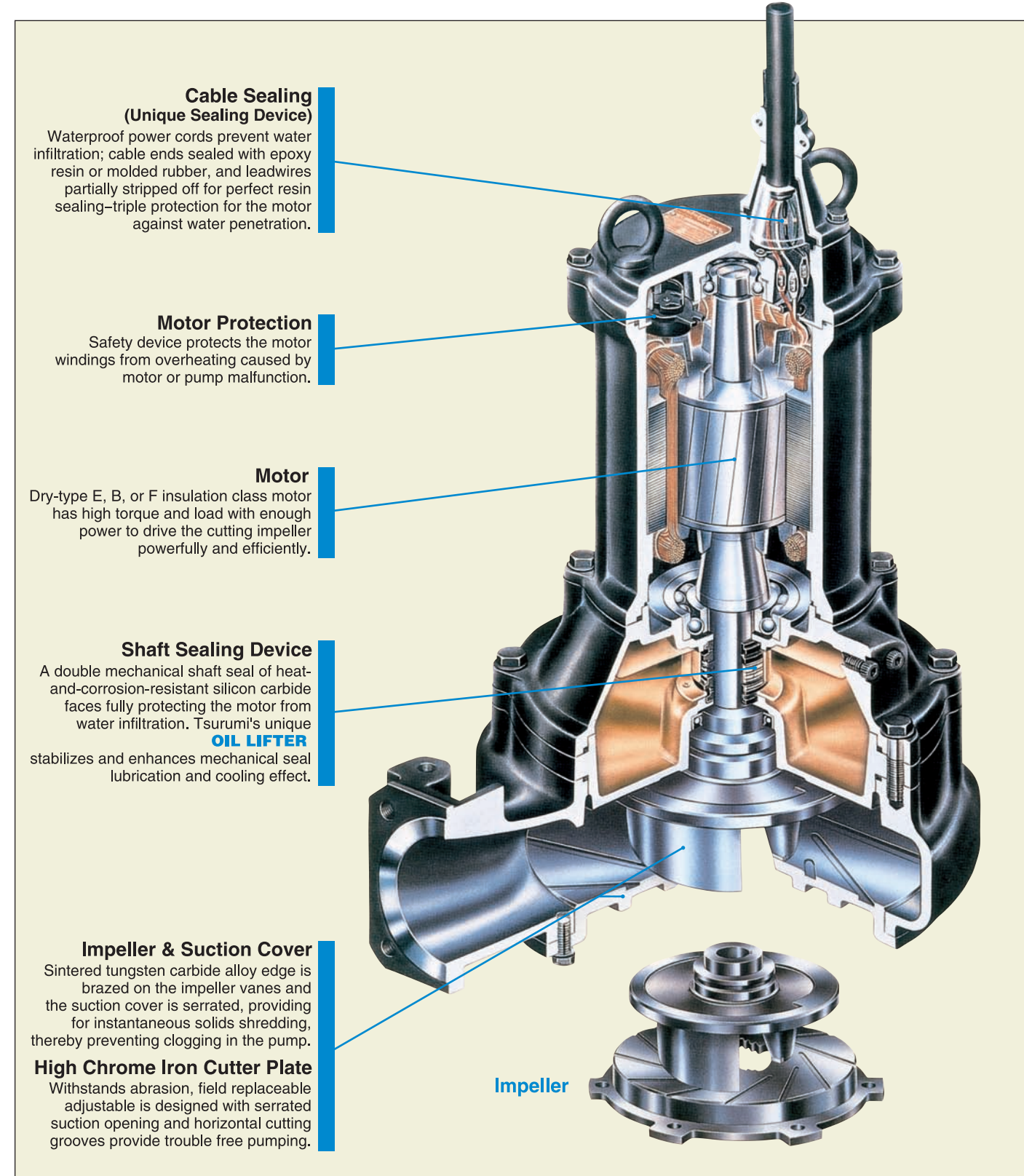

Cable Sealing (Unique Sealing Device)

Waterproof power cords prevent water infiltration; cable ends sealed with epoxy resin or molded rubber, and leadwires partially stripped off for perfect resin sealing—triple protection for the motor against water penetration.

Motor Protection

Safety device protects the motor windings from overheating caused by motor or pump malfunction.

Motor

Dry-type E, B, or F insulation class motor has high torque and load with enough power to drive the cutting impeller powerfully and efficiently.

Shaft Sealing Device

A double mechanical shaft seal of heat- and corrosion-resistant silicon carbide faces fully protecting the motor from water infiltration. Tsurumi's unique **OIL LIFTER** stabilizes and enhances mechanical seal lubrication and cooling effect.

Impeller & Suction Cover

Sintered tungsten carbide alloy edge is brazed on the impeller vanes and the suction cover is serrated, providing for instantaneous solids shredding, thereby preventing clogging in the pump.

High Chrome Iron Cutter Plate

Withstands abrasion, field replaceable adjustable is designed with serrated suction opening and horizontal cutting grooves provide trouble free pumping.

Impeller

Performance Curves

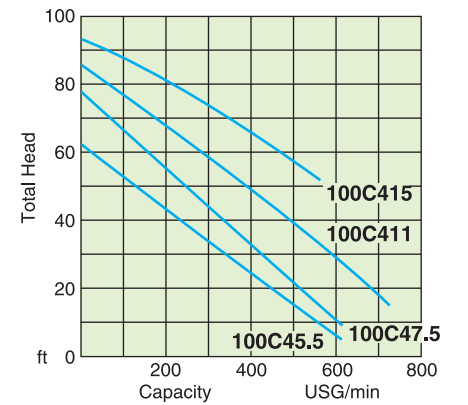
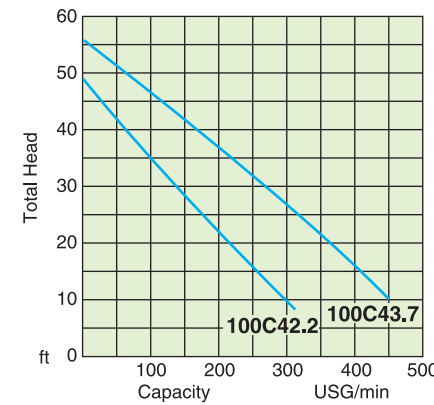
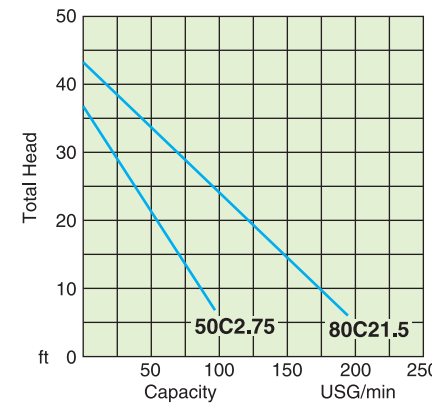

C Series High Head

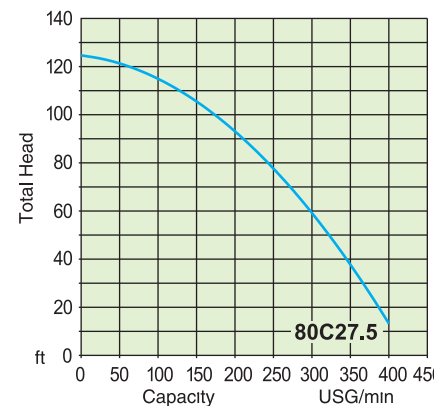
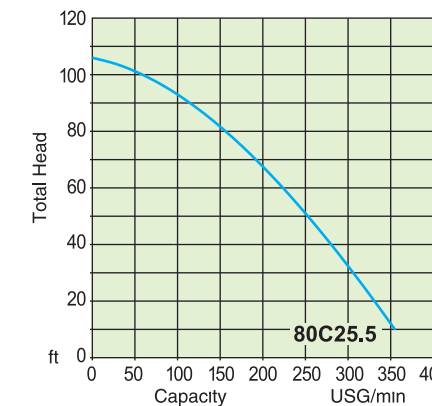
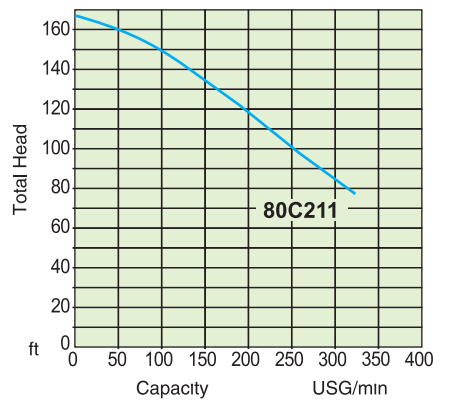
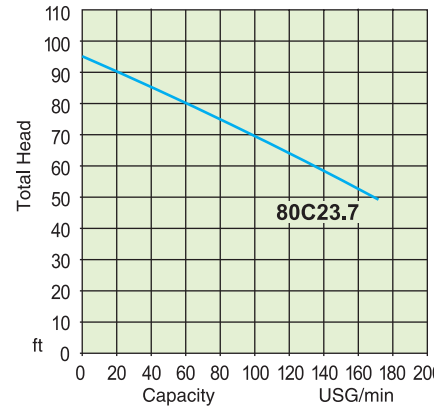
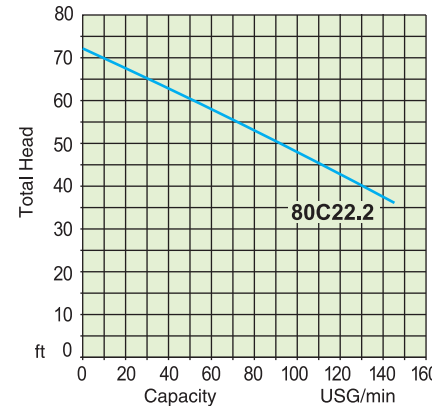

Specifications

- Note: 1) *1 Figures for body plus discharge bend weight.
2) *2 Figures for body only, not including guide hook, duck-foot bend, and other components. To get total TOS weight, add the weight of necessary components on the Standard Accessories table.
3) *3 Figures for Rated Current (A) are estimated.
4) Standard starting method: D.O.L. for 0.75 kW (1 HP) to 7.5 kW (10 HP) pumps, Cross-Wire Starting for those of 11 kW (15 HP) and over.
5) D.O.L. pumps are equipped with a circle thermal protector and Cross-Wire Starting pumps with a miniature protector, as standard equipment.
6) NPT flange is installed on all pumps.

Pumps

Discharge Bore (in.)	Model	Motor Output (HP)	Max. Head (ft)	Max. Capacity (USG/min)	*3 Rated Current (A)					S.S. Revolution (rpm)	Starting Method	Impeller		Weight	
					220V	230V	440V	460V	480V			Passage (in.)	No. of Vanes	Free Standing *1 (lb)	TOS-Model *2 (lb)
2	50C2.75	1	37	87	3.5	3.4	1.7	1.7	1.5	3600	D.O.L.	7/8 × 7/8	1	53	51
3	80C21.5	2	43	192	6.0	6.0	3.2	3.1	2.9	3600	D.O.L.	1 2/4 × 1 3/8	1	84	79
4	100C42.2	3	48	317	8.8	8.6	4.4	4.3	4.3	1800	D.O.L.	1 5/8 × 2 1/8	1	150	141
	100C43.7	5	55	462	14.2	13.8	7.1	6.8	6.5	1800		2 3/8 × 2 1/2	1	185	176
	100C45.5	7 1/2	62	616	21.2	19.2	10.5	9.6	9.2	1800		1 1/2 × 2 5/8	1	282	267
	100C47.5	10	78	629	27.6	26.0	13.7	13.0	12.4	1800	1 1/2 × 2 5/8	1	320	304	
	100C411	15	85	726	40.7	36.4	20.1	18.2	17.5	1800	Cross-Wire Starting	1 1/2 × 2 7/8	1	377	362
100C415	20	92	580	52.0	50.0	26.0	25.0	24.0	1800	Cross-Wire Starting	1 1/4 × 3 1/2	2	706	690	

High Head Pumps

Discharge Bore (in.)	Model	Motor Output (HP)	Max. Head (ft)	Max. Capacity (USG/min)	*3 Rated Current (A)			S.S. Revolution (rpm)	Starting Method	Impeller		Weight	
					230V	460V	575V			Passage (in.)	No. of Vanes	Free Standing *1 (lb)	TOS-Model *2 (lb)
3	80C22.2	3	74	146	9.5	5.0	3.8	3480	D.O.L. (Direct On Line)	0.79	2	139	130
	80C23.7	5	95	170	13.6	6.8	5.2	3410		0.87	2	141	132
	80C25.5	7.5	106	355	21.4	10.7	8.3	3545		0.91	2	278	265
	80C27.5	10	124	400	25.6	12.8	10.0	3545		0.91	2	284	271
	80C211	15	158	300	39.2	19.6	15.4	3525		0.98	2	326	313