

BERKELEY® B2ZPH

Cast Iron Impeller

Threaded Case (NPT), Packing Construction

ELECTRIC MOTOR DRIVE

Section	CC
Page	90.1
Date	March 4, 2013
Supersedes 07/01/11	

Table I

B/M No.	HP	PH	RPM	"U" Dim.	Imp. Dia.	Imp. No.
B58067	25	3	3600	1-1/4"	8.62"	M07667
B58149	30	3	3600	1-1/4"	9.00"	M07306

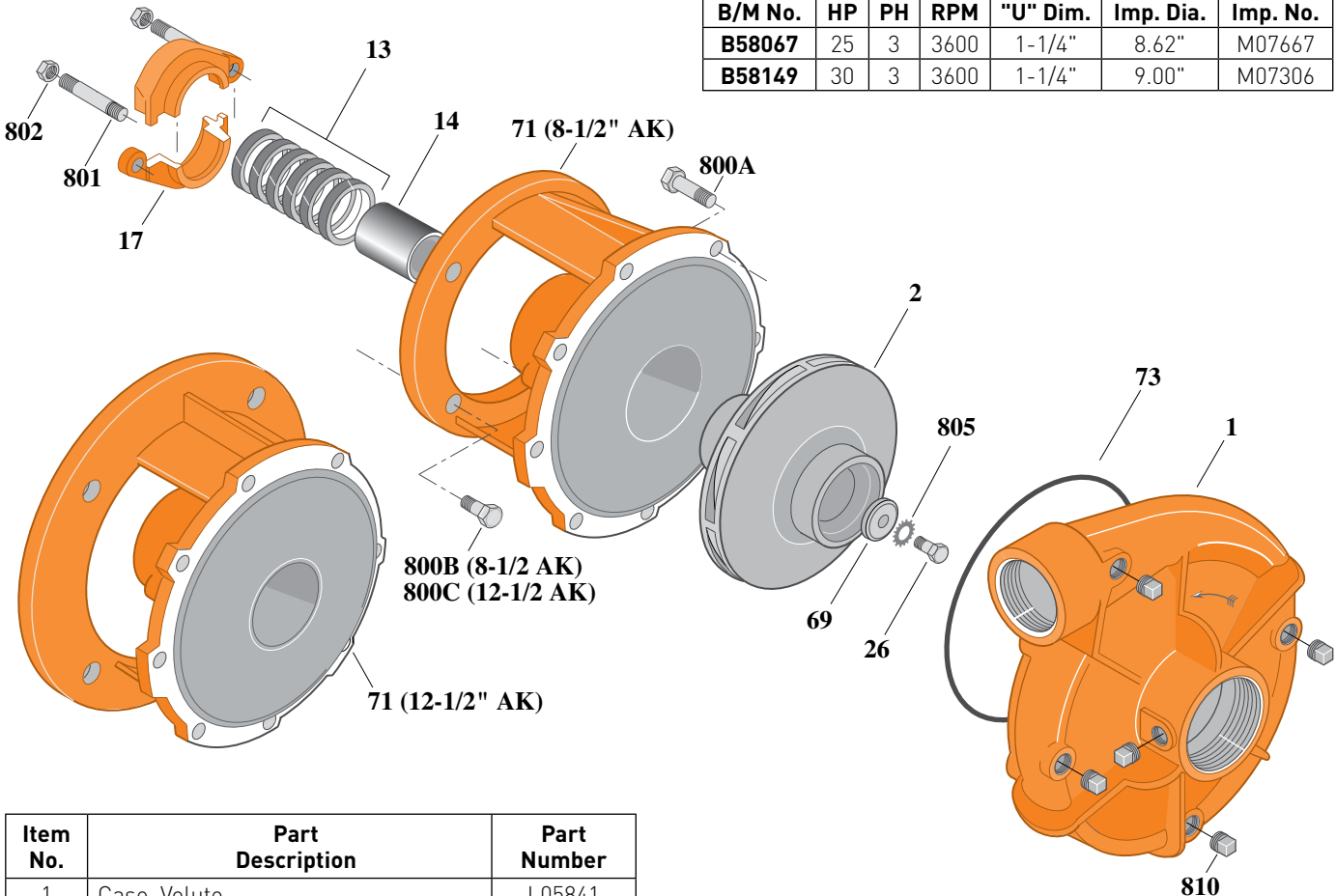

1744 1210

Item No.	Part Description	Part Number
1	Case, Volute	L05841
2	Impeller	See Table I
13	Rings, Packing (Set of 6)	S13470
14	Sleeve, Shaft	S05149L
17	Gland, Packing	B82470
26	Screw, Impeller 1/2 - 13 x 1"	S23619
32	Key, 1/4 x 2-1/4" [See Note 1]	S23677
69	Washer, Impeller	S06319
71	Bracket	See Table II
73	O-Ring [See Note 2]	M14943
800A	Capscrew, 3/8 - 16 x 1" [8 Req.]	S26826
800B	Capscrew, 1/2 - 13 x 1-1/2" [4 Req.]	S26916
800C	Capscrew, 5/8 - 11 x 1-1/2" [4 Req.]	S26999
801	Stud, 3/8 - 16 x 4" [2 Req.]	S08303
802	Nut, Hex 3/8 - 16 [2 Req.]	S23343
805	Washer, Lock	S23038
810	Plug, Pipe 1/4 NPT [5 Req.]	S23175

Table II

HP	PH	Bracket No.	"AK" Fit	"U" Dim.	Motor Frame
25	3	L03827	8-1/2"	1-1/4"	256JP
30	3	L01563	12-1/2"	1-1/4"	284JP

NOTE 1: For an explanation of the tabulated material found on this page and for impeller key location, refer to **Supplement A** located at the beginning of this section.

NOTE 2: Also accepts gasket **S05126** as replacement for O-Ring. See **Supplement E** located at the beginning of this section.



BERKELEY® B2ZPHS

Cast Iron Impeller

Threaded Case (NPT), Mechanical Shaft Seal Construction

ELECTRIC MOTOR DRIVE

Section	CC
Page	90.2
Date	March 4, 2013
Supersedes 07/01/11	

Table I

B/M No.	HP	PH	RPM	"U" Dim.	Imp. Dia.	Imp. No.
B58068	25	3	3600	1-1/4"	8.62"	M07667
B58069	30	3	3600	1-1/4"	9.00"	M07306

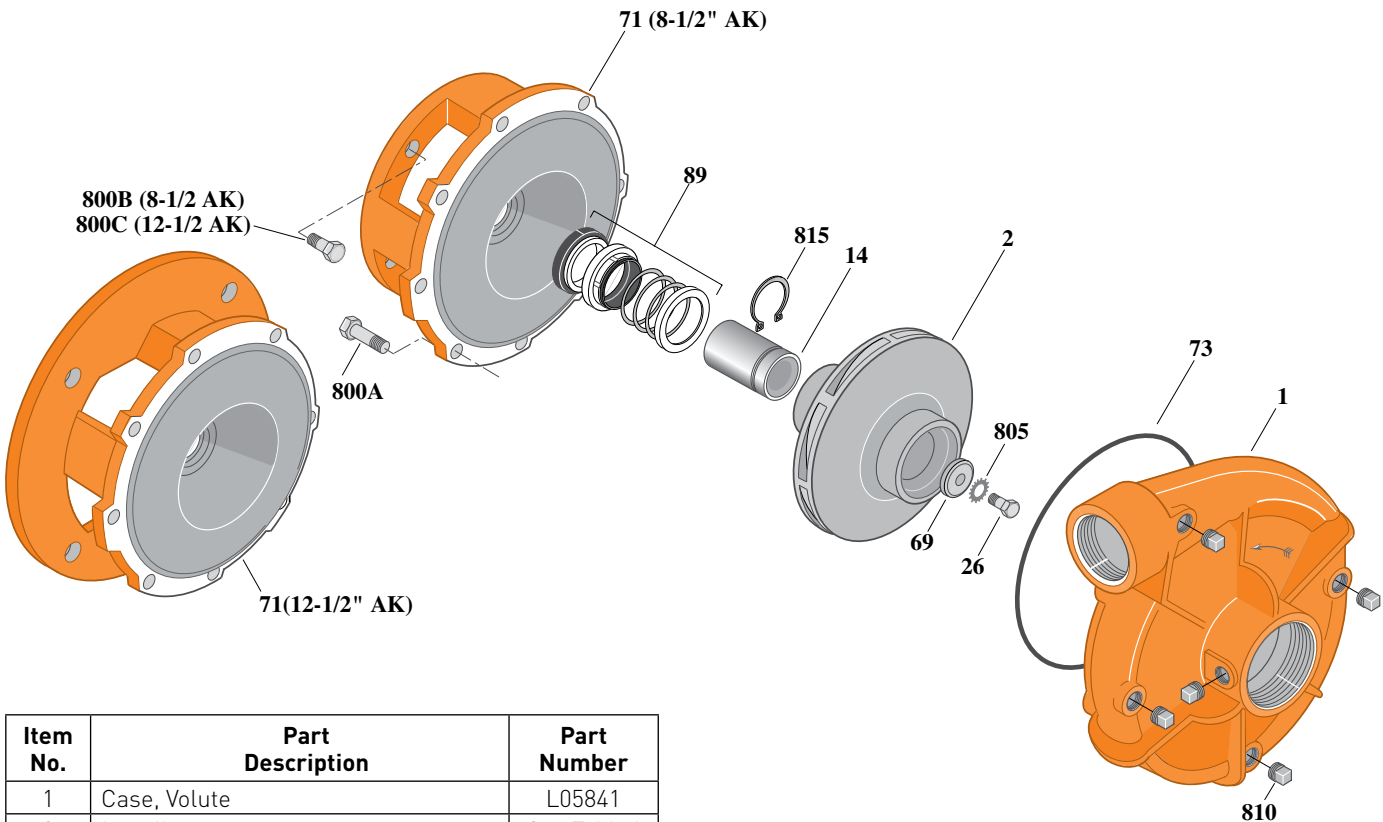

1608 1210

Item No.	Part Description	Part Number
1	Case, Volute	L05841
2	Impeller	See Table I
14	Sleeve, Shaft	S18869L
26	Screw, Impeller 1/2 - 13 x 1"	S23619
32	Key, 1/4 x 2-1/4" [See Note 1]	S23677
69	Washer, Impeller	S06319
71	Bracket	See Table II
73	O-Ring [See Note 2]	M14943
89	Seal, Mechanical Shaft	S32015
800A	Capscrew, 3/8 - 16 x 1" [8 Req.]	S26826
800B	Capscrew, 1/2 - 13 x 1" [4 Req.] [For 8-1/2 AK]	S26912
800B	Capscrew, 5/8 - 11 x 1-1/4" [4 Req.] [For 12-1/2 AK]	S26997
805	Washer, Lock	S23038
810	Plug, Pipe 1/4 NPT [5 Req.]	S23715
815	Ring, Retaining	S16767

Table II

HP	PH	Bracket No.	"AK" Fit	"U" Dim.	Motor Frame
25	3	L04615	8-1/2"	1-1/4"	256JM
30	3	L04627	12-1/2"	1-1/4"	284JM

NOTE 1: For an explanation of the tabulated material found on this page and for impeller key location, refer to **Supplement A** located at the beginning of this section.

NOTE 2: Also accepts gasket **S05126** as replacement for O-Ring. See **Supplement E** located at the beginning of this section.



BERKELEY® B2ZPHS

Cast Iron Impeller

Flanged Case, Mechanical Shaft Seal Construction

ELECTRIC MOTOR DRIVE

Section	CC
Page	90.3
Date	March 4, 2013
Supersedes 07/01/11	

Table I

B/M No.	HP	PH	RPM	"U" Dim.	Imp. Dia.	Imp. No.
B76253	25	3	3600	1-1/4"	8.62"	M07667
B76304	30	3	3600	1-1/4"	9.00"	M07306

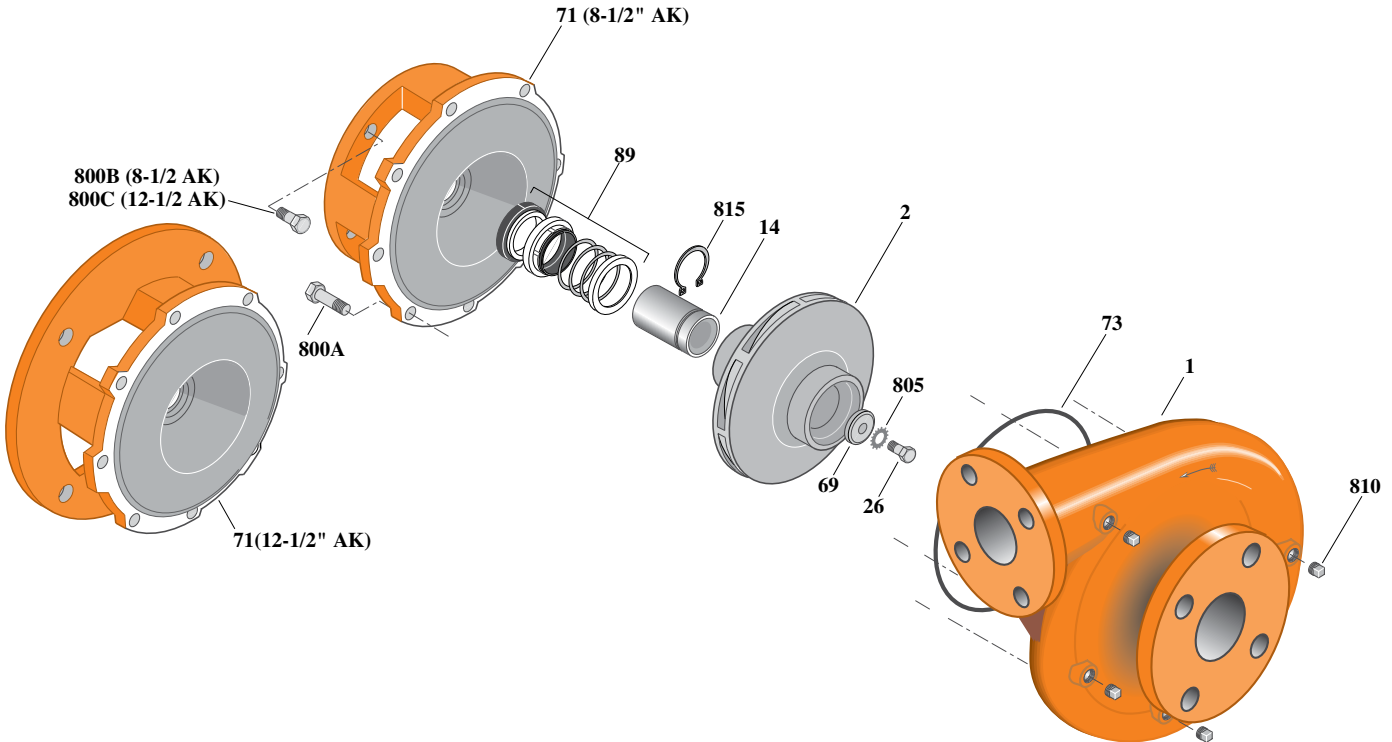

1608 1210 FL

Item No.	Part Description	Part Number
1	Case, Volute	H05543
2	Impeller	See Table I
14	Sleeve, Shaft	S18869L
26	Screw, Impeller 1/2 - 13 x 1"	S23619
32	Key, 1/4 x 2-1/4" [See Note 1]	S23677
69	Washer, Impeller	S06319
71	Bracket	See Table II
73	O-Ring [See Note 2]	M14943
89	Seal, Mechanical Shaft	S32015
800A	Capscrew, 3/8 - 16 x 1" [8 Req.]	S26826
800B	Capscrew, 1/2 - 13 x 1" [4 Req.] [For 8-1/2 AK]	S26912
800B	Capscrew, 5/8 - 11 x 1-1/4" [4 Req.] [For 12-1/2 AK]	S26997
805	Washer, Lock	S23038
810	Plug, Pipe 1/4 NPT [5 Req.]	S23715
815	Ring, Retaining	S16767

Table II

HP	PH	Bracket No.	"AK" Fit	"U" Dim.	Motor Frame
25	3	L04615	8-1/2"	1-1/4"	256JM
30	3	L04627	12-1/2"	1-1/4"	284JM

NOTE 1: For an explanation of the tabulated material found on this page and for impeller key location, refer to **Supplement A** located at the beginning of this section.

NOTE 2: Also accepts gasket **S05126** as replacement for O-Ring. See **Supplement E** located at the beginning of this section.

