

BERKELEY® B2XQKHS-5.5 AIR COOLED ENGINE DRIVE SELF PRIME

Cast Iron Impeller

Threaded Case (NPT), Mechanical Seal Construction

Section	AC/SP
Page	80.1
Date	March 4, 2013
Supersedes 04/01/96	

TABLE I

B/M No.	HP	Engine Mfr.	Engine Part No.	Mounting Type & Part No.
B71730	5.5	Honda	H05332	Base - L04044
B71917				Roll Cage - H05445
B71730	5.5	B & S Vanguard	H05330	Base - L04044
B71730				Roll Cage - H05445

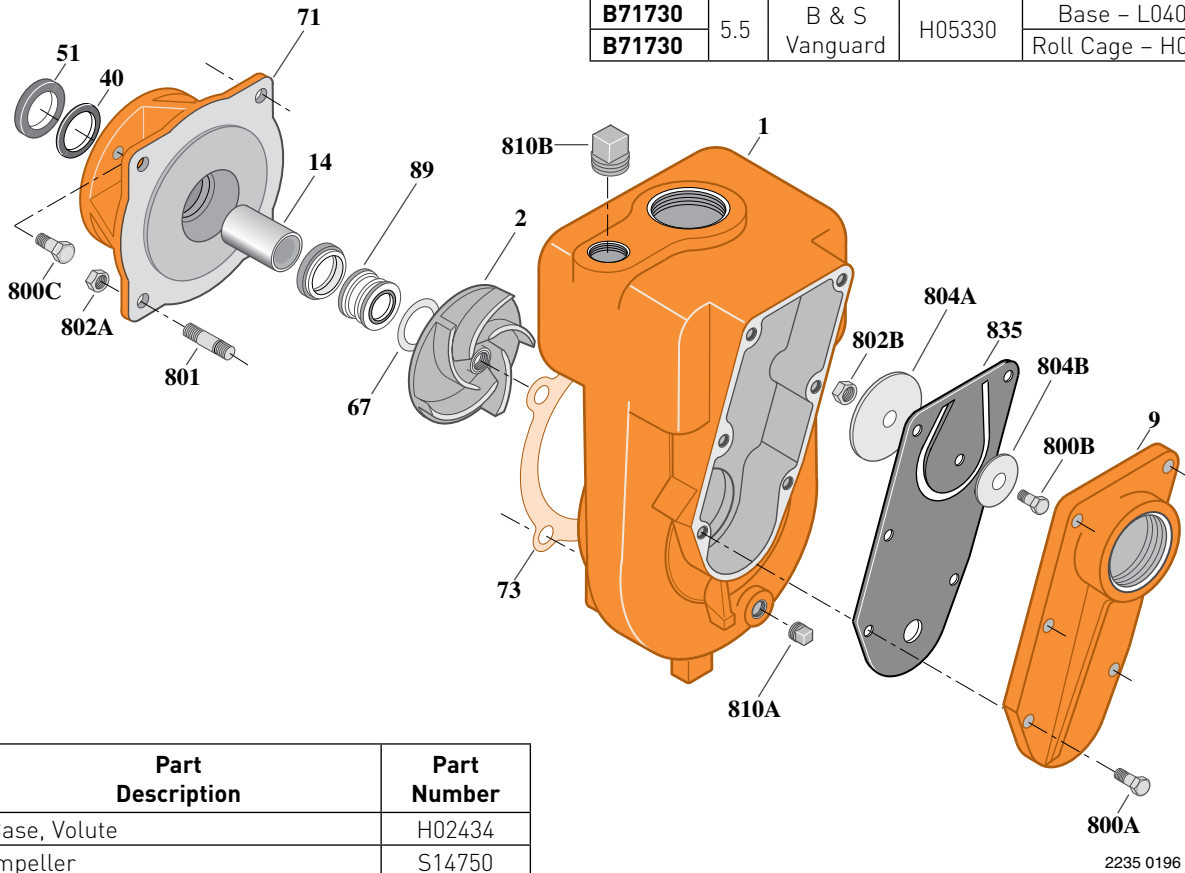

Item No.	Part Description	Part Number
1	Case, Volute	H02434
2	Impeller	S14750
9	Cover, Suction	M05420
14	Sleeve, Shaft	S14689
40	Slinger, Water	S11144
51	Seal, Oil	S13862
67	Shim (.015 Thick) (As Required)	S05067
71	Bracket	M05434
73	Gasket, Case	S04728
89	Seal, Mechanical Shaft	S05646
•227	Handle	M06914
800A	Cap screw, Hex 5/16-18x7/8" [6 Req.]	S26783
800B	Cap screw, Hex 1/4-20x3/8"	S23117
800C	Cap screw, Hex 5/16-24x3/4" [4 Req.]	S23168

Item No.	Part Description	Part Number
801	Stud, 3/8-16x1-1/4" [4 Req.]	S23994
802A	Nut, Hex 3/8-16 [4 Req.]	S23103
802B	Nut, Hex 1/4-20	S23100
804A	Weight, Clack	S14673
804B	Washer, Clack	S14676
810A	Plug, Pipe 1/4" NPT	S14692
810B	Plug, Pipe 1" NPT	S23693
835	Clack, Rubber	M05424

NOTE: Refer to **Supplement B** for base and roll cage configuration and mounting hardware.

• Not illustrated.

