

## SERIES 4280 | END SUCTION MOTOR MOUNTED CLOSED-COUPLED | 8 × 6 × 13 | SUBMITTAL

File No: 42.796  
Date: SEPTEMBER 10, 2012  
Supersedes: 42.796  
Date: DECEMBER 15, 2010

Job: \_\_\_\_\_ Representative: \_\_\_\_\_  
 \_\_\_\_\_ Order no: \_\_\_\_\_ Date: \_\_\_\_\_  
 Engineer: \_\_\_\_\_ Submitted by: \_\_\_\_\_ Date: \_\_\_\_\_  
 Contractor: \_\_\_\_\_ Approved by: \_\_\_\_\_ Date: \_\_\_\_\_

### PUMP DESIGN DATA

No. of pumps: \_\_\_\_\_ Tag: \_\_\_\_\_  
 Capacity: \_\_\_\_\_ USgpm (L/s) Head: \_\_\_\_\_ ft (m)  
 Liquid: \_\_\_\_\_ Viscosity: \_\_\_\_\_  
 Temperature: \_\_\_\_\_ °F (°C) Specific gravity: \_\_\_\_\_  
 Suction: 8" (200mm) Lugged  
 Discharge: 6" (150mm) Flanged

### MOTOR DESIGN DATA

HP: \_\_\_\_\_ RPM: \_\_\_\_\_ Frame size: \_\_\_\_\_ Enclosure: \_\_\_\_\_  
 Volts: \_\_\_\_\_ Hertz: 60 Hz Phase: 3  
 Efficiency:  Energy EFF 12.11  NEMA premium 12.12

### MATERIALS OF CONSTRUCTION

ANSI FLANGE RATING	ANSI 125	ANSI 250
<b>Construction</b>	<input type="checkbox"/> BF	<input type="checkbox"/> DBF
<b>Casing</b>	Cast iron	Ductile iron
<b>Adapter</b>	Cast iron	Ductile iron

**Impeller:** Bronze

**Gasket:** Confined non-asbestos fiber

**Shaft:** Carbon steel

**Shaft sleeve:** Bronze

### MAXIMUM PUMP OPERATING CONDITIONS

#### ANSI 125

175 psig at 150°F (12 bars at 65°C)  
 140 psig at 250°F (10 bars at 121°C)

#### ANSI 250

300 psig at 150°F (20 bars at 65°C)  
 250 psig at 250°F (17 bars at 121°C)

- Tolerance of ±0.125" (±3 mm) should be used
- See performance curves on page 3
- For exact installation, data please write factory for certified dimensions
- Pump equipped with casing drain plug and ¼" NPT suction and discharge gauge ports

### MECHANICAL SEAL DATA

**Seal type:** 2A **Stationary seat:** Silicone carbide  
**Secondary seal:** EPDM **Rotating hardware:** Stainless steel  
**Spring:** Stainless steel

### OPTIONAL EQUIPMENT

FLUID TYPE	ALL GLYCOLS > 30% WT CONC		ALL OTHER NON-POTABLE FLUIDS		POTABLE (DRINKING) WATER	
	up to 200°F (93°C)	over 200°F (93°C)	up to 200°F (93°C)	over 200°F (93°C)	up to 200°F (93°C)	over 200°F (93°C)
<b>Temperature</b>	up to 200°F (93°C)	over 200°F (93°C)	up to 200°F (93°C)	over 200°F (93°C)	up to 200°F (93°C)	over 200°F (93°C)
<b>Rotating face</b>	Silicone carbide		Resin bonded carbon	Antimony loaded carbon	Resin bonded carbon	
<b>Seat elastomer</b>	EPDM (L-cup)	EPDM (O-ring)	EPDM (L-cup)	EPDM (O-ring)	EPDM (L-cup)	EPDM (O-ring)
<b>Material code</b>	SCSC L EPSS 2A	SCSC O EPSS 2A	C-SC L EPSS 2A	ACSC O EPSS 2A	C-SC L EPSS 2A	C-SC O EPSS 2A

MOTOR FRAME	HP @ RPM (ODP & TEFC)		MAX. DIMENSIONS INCHES (mm)										ASSEMBLY WEIGHT*	
	1800	1200	A	B	C MAX		D1	D2	E	F	H	N	lbs (kgs)	
					ODP	TEFC							ODP	TEFC
254JM	—	7.5	12.38 (314)	10.50 (267)	22.00 (559)	24.00 (610)	12.00 (305)	6.25 (159)	5.00 (127)	8.25 (210)	0.53 (13)	9.75 (248)	654 (296.7)	665 (301.7)
256JM	—	10	12.38 (314)	12.25 (311)	24.00 (610)	26.00 (660)	12.00 (305)	6.25 (159)	5.00 (127)	10.00 (254)	0.53 (13)	9.75 (248)	688 (312.2)	698 (316.7)
284JP	—	15	13.88 (353)	12.25 (311)	26.88 (683)	28.88 (734)	12.00 (305)	7.00 (178)	5.50 (140)	9.50 (241)	0.53 (13)	12.88 (327)	721 (327.1)	783 (355.3)
286JP	30	20	13.88 (353)	13.75 (349)	28.88 (734)	29.88 (759)	12.00 (305)	7.00 (178)	5.50 (140)	11.00 (279)	0.53 (13)	12.88 (327)	763 (346.2)	923 (418.8)
324JP	40	—	15.88 (403)	13.75 (349)	28.88 (734)	30.88 (784)	12.00 (305)	8.00 (203)	6.25 (159)	10.50 (267)	0.66 (17)	13.13 (334)	903 (409.7)	1013 (459.6)
326JP	50	—	15.88 (403)	15.25 (387)	30.88 (784)	32.88 (835)	12.00 (305)	8.00 (203)	6.25 (159)	12.00 (305)	0.66 (17)	13.13 (334)	943 (427.9)	1073 (486.8)

**PUMP DIMENSIONS**

inches (mm)

X	Y
16.00 (406)	4.00 (102)

\*Assembly weight combines pump and motor.

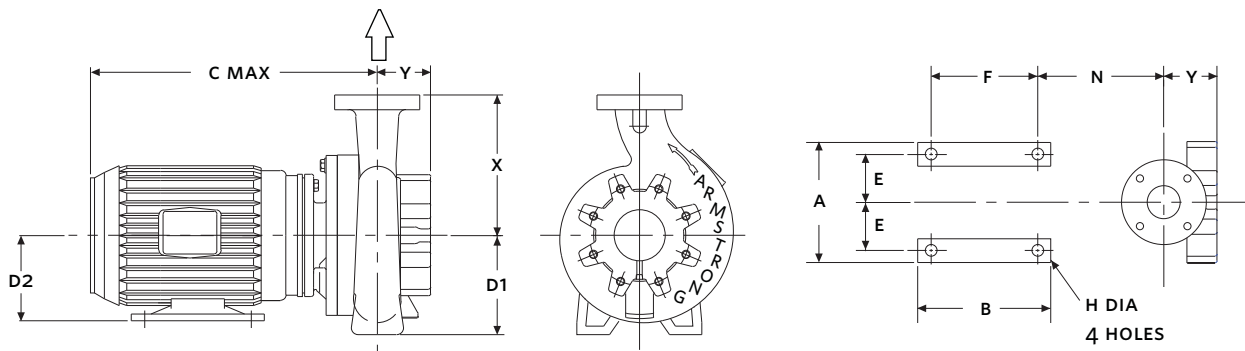

**SERIES 4280 PERFORMANCE CURVES**

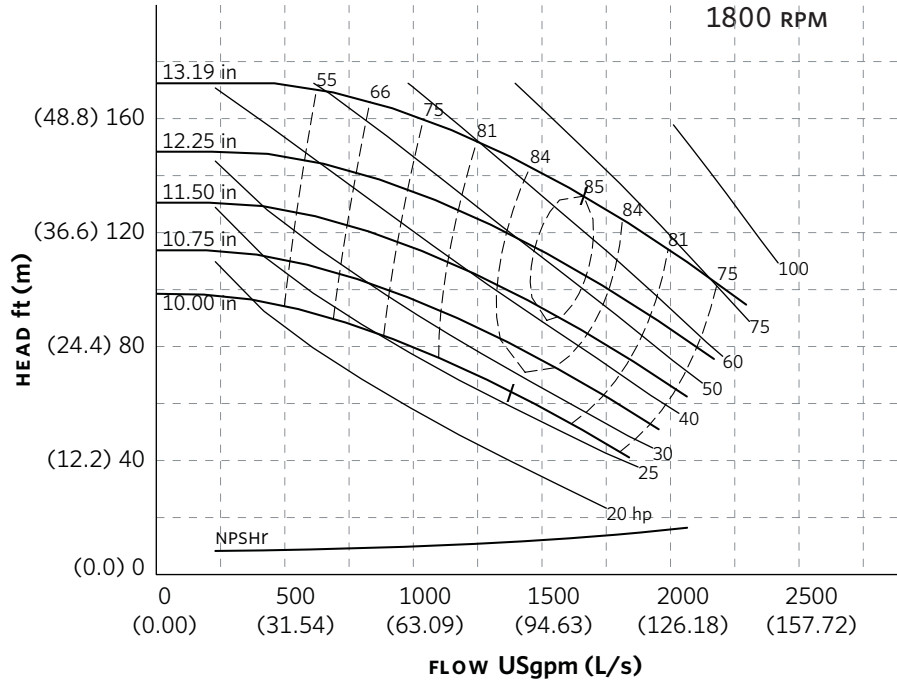

**Curve number**  
PT110-1-0-1800

**Series**  
4030  
4280

**Size**  
8 × 6 × 13

**RPM**  
1800

BHP based on shown  
Fluid's sp. gr.

**Availability**  
4030 all ratings  
4280 all ratings

Performance  
guaranteed only  
at operating point  
indicated.

Curve shown for  
clear, cold water  
- SP. GR. 1.0000

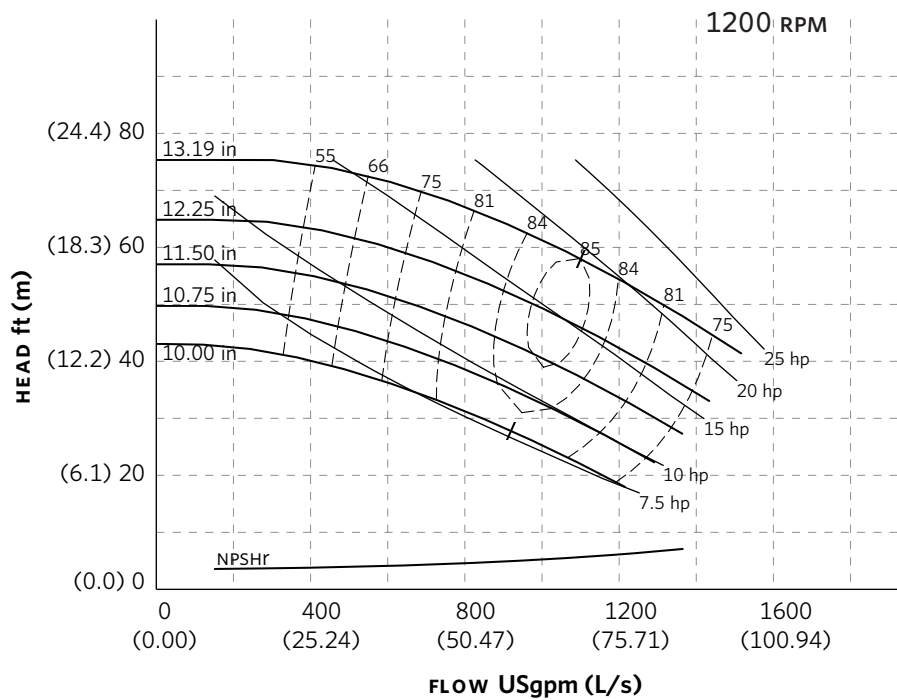

**Curve number**  
PT110-1-0-1200

**Series**  
4030  
4280

**Size**  
8 × 6 × 13

**RPM**  
1200

BHP based on shown  
Fluid's sp. gr.

**Availability**  
4030 all ratings  
4280 all ratings

Performance  
guaranteed only  
at operating point  
indicated.

Curve shown for  
clear, cold water  
- SP. GR. 1.0000

Performance curves are for reference only.  
Confirm current performance data with Armstrong ACE ONLINE selection software.

**TORONTO**

23 BERTRAND AVENUE  
TORONTO, ONTARIO  
CANADA  
M1L 2P3  
+1 416 755 2291

**BUFFALO**

93 EAST AVENUE  
NORTH TONAWANDA, NEW YORK  
U.S.A.  
14120-6594  
+1 716 693 8813

**BIRMINGHAM**

HEYWOOD WHARF, MUCKLOW HILL  
HALESOWEN, WEST MIDLANDS  
UNITED KINGDOM  
B62 8DJ  
+44 (0) 8444 145 145

**MANCHESTER**

WENLOCK WAY  
MANCHESTER  
UNITED KINGDOM  
M12 5JL  
+44 (0) 8444 145 145

**BANGALORE**

#59, FIRST FLOOR, 3RD MAIN  
MARGOSA ROAD, MALLESWARAM  
BANGALORE, INDIA  
560 003  
+91 (0) 80 4906 3555

**SHANGHAI**

NO. 1619 HU HANG ROAD, XI DU TOWNSHIP  
FENG XIAN DISTRICT, SHANGHAI  
P.R.C.  
201401  
+86 21 3756 6696

ARMSTRONG INTEGRATED  
ESTABLISHED 1934

ARMSTRONGINTEGRATED.COM

**MAKING  
ENERGY  
MAKE  
SENSE™**