

<p>JOB:</p> <p>UNIT TAG:</p> <p>ENGINEER:</p> <p>CONTRACTOR:</p>	<p>REPRESENTATIVE:</p> <p>ORDER NO.</p> <p>SUBMITTED BY:</p> <p>APPROVED BY:</p>	<p>DATE:</p> <p>DATE:</p> <p>DATE:</p>
-----------------------------------------------------------------------------------------------------	---------------------------------------------------------------------------------------------------------------------	-------------------------------------------------------------

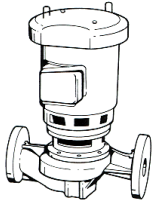

8x8x11

Series 80[®]

In-Line Mounted Centrifugal Pumps

SPECIFICATIONS

FLOW _____ HEAD _____

HP _____ RPM _____

VOLTS _____

CYCLE _____ PHASE _____

ENCLOSURE _____

APPROX. WEIGHT _____

SPECIALS _____

MATERIALS OF CONSTRUCTION

- BRONZE FITTED ALL IRON

MAXIMUM WORKING PRESSURE

- 175 psi (12 bar) W.P. with 125# ANSI flange drilling
- 250 psi (17 bar) W.P. with 250# ANSI flange drilling (requires 80-S)
- 300 psi (21 bar) W.P. with 250# ANSI flange drilling (EPR-Sintered Silicon Carbide-Sintered Silicon Carbide) Requires 80-S

TYPE OF SEAL

- 80 Standard Seal (Buna-Carbon/Ceramic)
- 80 -F Standard Seal w/ Flush Line (Buna-Carbon/Ceramic)
- 80 -S Stuffing Box construction w/ Flushed Mechanical Single Seal (EPR-Tungsten Carbide/Carbon)
- 80 -D Stuffing Box construction w/ Flushed Double Mechanical Seal (EPR-Carbon/Ceramic) Requires external water source
- 80 -PF Stuffing Box Construction w/ Flushed Packing (Graphite Impregnated PTFE)

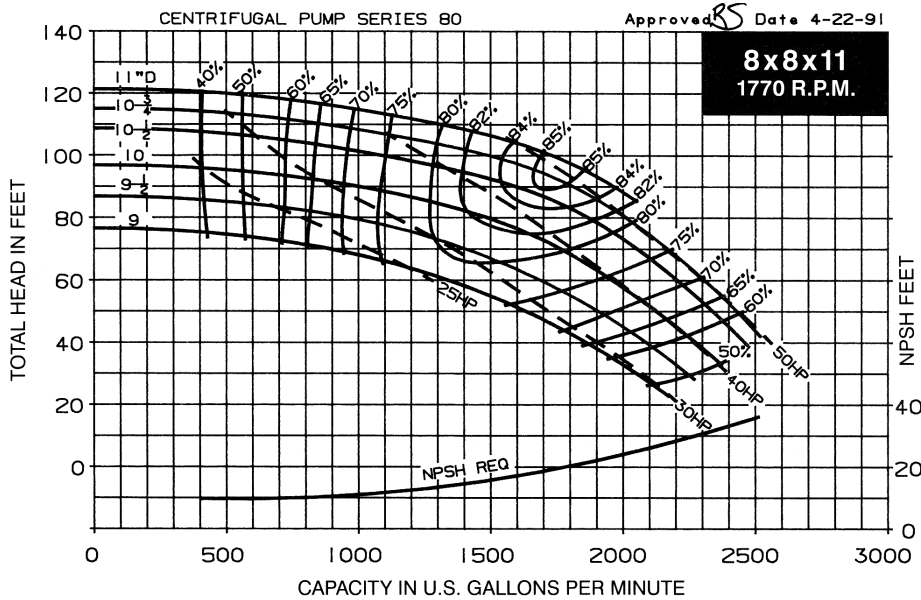

JOB: UNIT TAG: ENGINEER: CONTRACTOR:	REPRESENTATIVE: ORDER NO.: SUBMITTED BY: APPROVED BY:	DATE: DATE: DATE:
-----------------------------------------------------------------------------------	----------------------------------------------------------------------------------------------------	----------------------------------------------

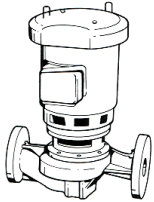

8x8x11

Series 80[®]

In-Line Mounted Centrifugal Pumps

SPECIFICATIONS

FLOW _____ HEAD _____
 HP _____ RPM _____
 VOLTS _____
 CYCLE _____ PHASE _____
 ENCLOSURE _____
 APPROX. WEIGHT _____
 SPECIALS _____

MATERIALS OF CONSTRUCTION

BRONZE FITTED ALL IRON

MAXIMUM WORKING PRESSURE

- 175 psi (12 bar) W.P. with 125# ANSI flange drilling
- 250 psi (17 bar) W.P. with 250# ANSI flange drilling (requires 80-S)
- 300 psi (21 bar) W.P. with 250# ANSI flange drilling (EPR-Sintered Silicon Carbide-Sintered Silicon Carbide) Requires 80-S

TYPE OF SEAL

- 80 Standard Seal (Buna-Carbon/Ceramic)
- 80 -F Standard Seal w/ Flush Line (Buna-Carbon/Ceramic)
- 80 -S Stuffing Box construction w/ Flushed Mechanical Single Seal (EPR-Tungsten Carbide/Carbon)
- 80 -D Stuffing Box construction w/ Flushed Double Mechanical Seal (EPR-Carbon/Ceramic) Requires external water source
- 80 -PF Stuffing Box Construction w/ Flushed Packing (Graphite Impregnated PTFE)

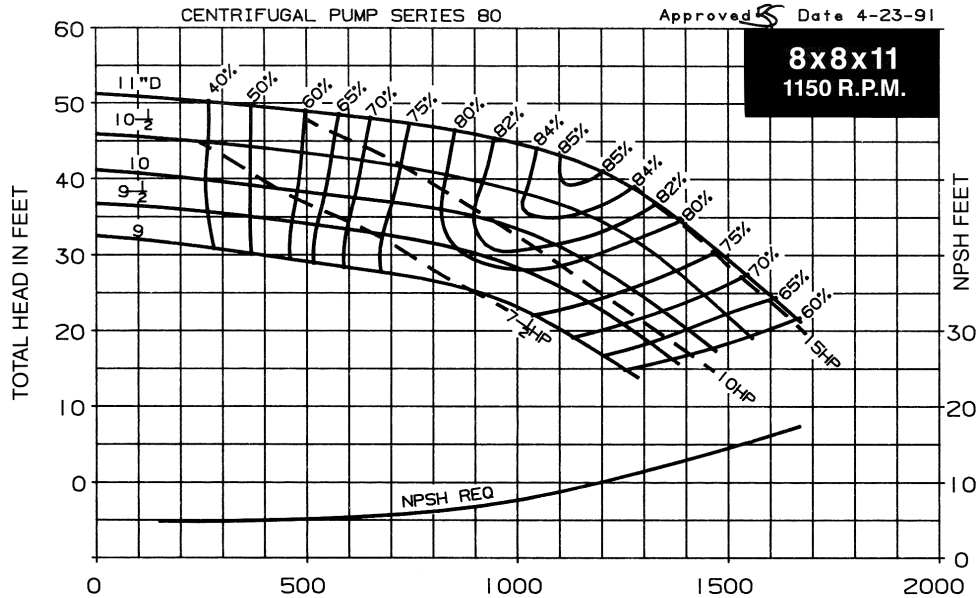

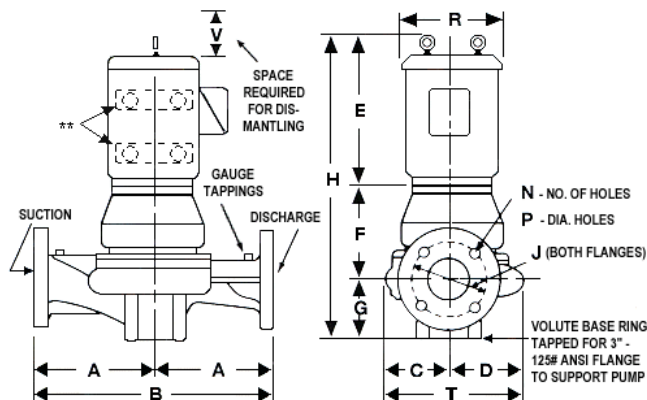

FLANGE DIMENSIONS IN INCHES (MM)			
	SIZE	THICKNESS	O.D.
Discharge	8"	1-5/8 (41)	14-3/4 (375)
Suction	8"	1-5/8 (41)	14-3/4 (375)

FLANGES ARE 125# ANSI - STANDARD
250# ANSI - AVAILABLE

** Motor may be supplied with feet

DIMENSIONS - Inches (mm)

STANDARD SEAL 80, 80-F

MOTOR FRAME	A	B	C	D	E (Max)	F	G	H (Max)	125# ANSI			250# ANSI			R	S (Max)*	T	V (Min)
									J	N	P	J	N	P				
254	18 (457)	36 (914)	9 (229)	11-3/8 (289)	24-1/8 (613)	8-1/8 (206)	10-1/4 (260)	42-1/2 (1080)	11-3/4 (298)	8	7/8 (22)	13 (330)	12	7/8 (22)	17 (432)	-	20-3/8 (518)	5-3/4 (146)
256	18 (457)	36 (914)	9 (229)	11-3/8 (289)	24-1/8 (613)	8-1/8 (206)	10-1/4 (260)	42-1/2 (1080)	11-3/4 (298)	8	7/8 (22)	13 (330)	12	7/8 (22)	17 (432)	-	20-3/8 (518)	5-3/4 (146)
284	18 (457)	36 (914)	9 (229)	11-3/8 (289)	23-5/8 (600)	8-1/8 (206)	10-1/4 (260)	42 (1067)	11-3/4 (298)	8	7/8 (22)	13 (330)	12	7/8 (22)	16-1/8 (410)	4-5/8 (117)	20-3/8 (518)	5-3/4 (146)
286	18 (457)	36 (914)	9 (229)	11-3/8 (289)	25-1/8 (638)	8-1/8 (206)	10-1/4 (260)	43-1/2 (1105)	11-3/4 (298)	8	7/8 (22)	13 (330)	12	7/8 (22)	16-1/8 (410)	4-5/8 (117)	20-3/8 (518)	5-3/4 (146)
324	18 (457)	36 (914)	9 (229)	11-3/8 (289)	26 (660)	8-1/8 (206)	10-1/4 (260)	44-3/8 (1127)	11-3/4 (298)	8	7/8 (22)	13 (330)	12	7/8 (22)	18-3/4 (476)	4-5/8 (117)	20-3/8 (518)	5-3/4 (146)
326	18 (457)	36 (914)	9 (229)	11-3/8 (289)	26 (660)	8-1/8 (206)	10-1/4 (260)	44-3/8 (1127)	11-3/4 (298)	8	7/8 (22)	13 (330)	12	7/8 (22)	18-3/4 (476)	4-5/8 (117)	20-3/8 (518)	5-3/4 (146)

STUFFING BOX 80-PF, 80-S, 80-D

MOTOR FRAME	A	B	C	D	E (Max)	F	G	H (Max)	125# ANSI			250# ANSI			R	S (Max)*	T	V (Min)
									J	N	P	J	N	P				
254	18 (457)	36 (914)	9 (229)	11-3/8 (289)	24-1/8 (613)	8-1/8 (206)	10-1/4 (260)	42-1/2 (1080)	11-3/4 (298)	8	7/8 (22)	13 (330)	12	7/8 (22)	17 (432)	-	20-3/8 (518)	5-3/4 (146)
256	18 (457)	36 (914)	9 (229)	11-3/8 (289)	24-1/8 (613)	8-1/8 (206)	10-1/4 (260)	42-1/2 (1080)	11-3/4 (298)	8	7/8 (22)	13 (330)	12	7/8 (22)	17 (432)	-	20-3/8 (518)	5-3/4 (146)
284	18 (457)	36 (914)	9 (229)	11-3/8 (289)	23-5/8 (600)	8-1/8 (206)	10-1/4 (260)	42 (1067)	11-3/4 (298)	8	7/8 (22)	13 (330)	12	7/8 (22)	16-1/8 (410)	4-5/8 (117)	20-3/8 (518)	5-3/4 (146)
286	18 (457)	36 (914)	9 (229)	11-3/8 (289)	25-1/8 (638)	8-1/8 (206)	10-1/4 (260)	43-1/2 (1105)	11-3/4 (298)	8	7/8 (22)	13 (330)	12	7/8 (22)	16-1/8 (410)	4-5/8 (117)	20-3/8 (518)	5-3/4 (146)
324	18 (457)	36 (914)	9 (229)	11-3/8 (289)	26 (660)	8-1/8 (206)	10-1/4 (260)	44-3/8 (1127)	11-3/4 (298)	8	7/8 (22)	13 (330)	12	7/8 (22)	18-3/4 (476)	4-5/8 (117)	20-3/8 (518)	5-3/4 (146)
326	18 (457)	36 (914)	9 (229)	11-3/8 (289)	26 (660)	8-1/8 (206)	10-1/4 (260)	44-3/8 (1127)	11-3/4 (298)	8	7/8 (22)	13 (330)	12	7/8 (22)	18-3/4 (476)	4-5/8 (117)	20-3/8 (518)	5-3/4 (146)

Dimensions are subject to change. Not to be used for construction purposes unless certified.

NOTE: For 1 phase Motors add 1" to dimensions E & H.

*For TEFC Motors add S dimension to dimensions E & H.

Xylem Inc.
8200 N. Austin Avenue
Morton Grove, IL 60053
Phone: (847)966-3700
Fax: (847)965-8379
www.bellgossett.com



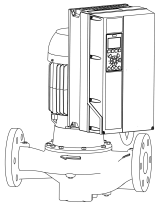

8x8x11 Series 80[®]

In-Line Mounted Centrifugal Pumps
With Optional Integrated Technologic[®] featuring Sensorless Control

TECHNOLOGIC STANDARD FEATURES	
CONTROL METHOD	Constant Pressure, Linear Control Curve, Quadratic Control Curve Factory configured for sensorless operation standard. Field configurable for use with a wired transducer.
ENCLOSURE	IP55 / NEMA 12 / UL type 12
POWER DISCONNECT SWITCH	Included standard. Fused Disconnect Switch optional.
EMI/RFI CONTROL	Integrated filter to meet EN62800-3.
HARMONIC SUPPRESSION	Integrated non-saturating dual DC link reactors provide better harmonic performance than a 5% AC line reactor.
COOLING	Fan-cooled through temperature controlled and easy replacement.
AMBIENT TEMPERATURE RATING	14°F to 113°F (-10°C to 45°C)
COMMUNICATION PROTOCOLS	BACnet, Modbus RTU, N2 Metasys, FLN Apogee
ANALOG INPUTS	2 configurable for either voltage (0 to 10VDC) or current(0/4 to 20mA)
ANALOG OUTPUTS	1 (0/4 to 20mA) up to 500 ohm load accurate to 1% of full scale
DIGITAL INPUTS	4 (0 to 24VDC), NPN or PNP, 0 to 24VDC, on 5 msec scan interval, Up to 2 can be configured as pulse inputs.
DIGITAL OUTPUTS	2 (0 to 24VDC), 40mA max current, configurable as pulse outputs.
RELAY OUTPUTS	2 programmable, 240VAC or 400VAC up to 2 A

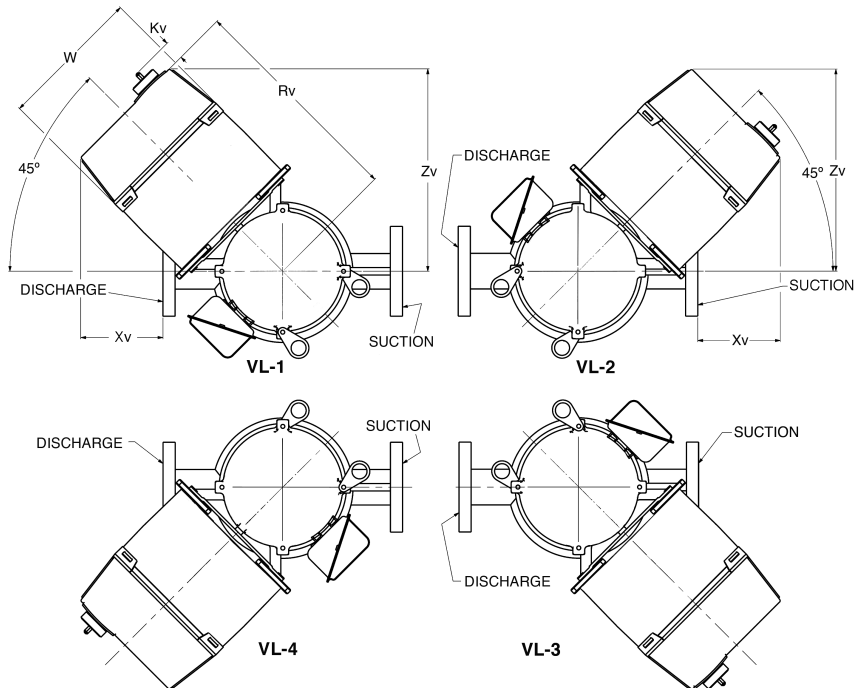
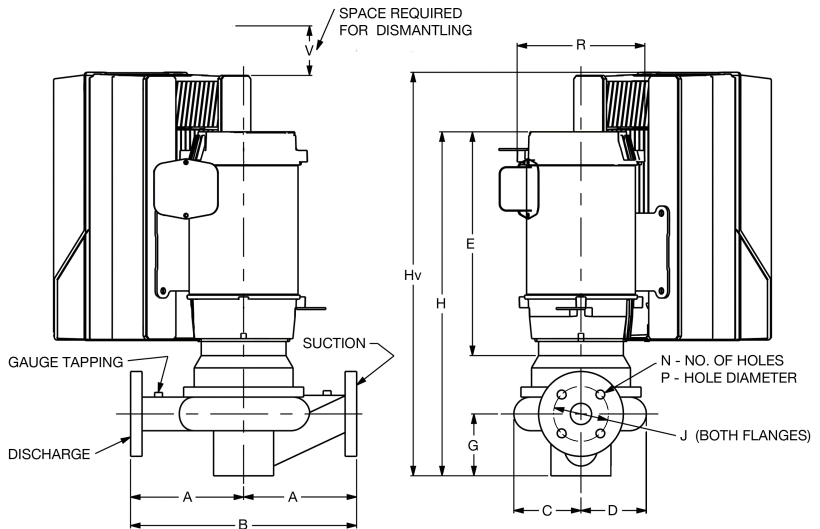

Xylem Inc.
8200 N. Austin Avenue
Morton Grove, IL 60053
Phone: (847)966-3700
Fax: (847)965-8379
www.bellgossett.com

xylem
Let's Solve Water

Bell & Gossett is a trademark of Xylem Inc. or one of its subsidiaries.
© 2013 Xylem Inc.

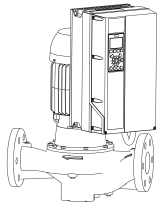

8x8x11 Series 80[®]

In-Line Mounted Centrifugal Pumps
With Optional Integrated Technologic[®] featuring Sensorless Control

DIMENSIONS – Inches (mm)

STANDARD SEAL 80, 80-F

MOTOR FRAME	A	B	E (Max)	G	H (Max)	125# ANSI			250# ANSI			R	VFD	Rv	Zv	W	Hv	Xv
						J	N	P	J	N	P							
254	18 (457)	36 (914)	24-1/8 (613)	10-1/4 (260)	42-1/2 (1080)	11-3/4 (298)	8	7/8 (22)	13 (330)	12	7/8 (22)	17 (432)	A5	14-17/32 (369)	13-17/64 (337)	9-1/2 (241)	42-1/2 (1079)	4-47/64 (120)
256	18 (457)	36 (914)	24-1/8 (613)	10-1/4 (260)	42-1/2 (1080)	11-3/4 (298)	8	7/8 (22)	13 (330)	12	7/8 (22)	17 (432)	A5	14-17/32 (369)	13-17/64 (337)	9-1/2 (241)	42-1/2 (1079)	4-47/64 (120)
													B1	16-53/64 (427)	14-59/64 (379)	9-1/2 (241)	44-7/8 (1140)	3-5/64 (78)
284	18 (457)	36 (914)	23-5/8 (600)	10-1/4 (260)	42 (1067)	11-3/4 (298)	8	7/8 (22)	13 (330)	12	7/8 (22)	16-1/8 (410)	B1	17-37/64 (446)	15-29/64 (392)	9-1/2 (241)	44-1/4 (1124)	2-35/64 (65)
286	18 (457)	36 (914)	25-1/8 (638)	10-1/4 (260)	43-1/2 (1105)	11-3/4 (298)	8	7/8 (22)	13 (330)	12	7/8 (22)	16-1/8 (410)	B1	17-37/64 (446)	15-29/64 (392)	9-1/2 (241)	45-3/4 (1162)	2-35/64 (65)
													B2	17-37/64 (446)	15-29/64 (392)	9-1/2 (241)	50-13/64 (1275)	2-35/64 (65)
													C1	19-37/64 (497)	17-5/8 (448)	12-3/32 (307)	52-39/64 (1336)	3/8 (10)
324	18 (457)	36 (914)	26 (660)	10-1/4 (260)	44-3/8 (1127)	11-3/4 (298)	8	7/8 (22)	13 (330)	12	7/8 (22)	18-3/4 (476)	B2	18-37/64 (472)	16-5/32 (410)	9-1/2 (241)	49-35/64 (1259)	1-27/32 (47)
													C1	20-37/64 (523)	18-21/64 (465)	12-3/32 (307)	49-57/64 (1267)	21/64 (8)
326	18 (457)	36 (914)	26 (660)	10-1/4 (260)	44-3/8 (1127)	11-3/4 (298)	8	7/8 (22)	13 (330)	12	7/8 (22)	18-3/4 (476)	C1	20-37/64 (523)	18-21/64 (465)	12-3/32 (307)	49-57/64 (1267)	21/64 (8)
													C2	21-37/64 (548)	19-7/8 (505)	14-19/32 (371)	54-29/64 (1383)	1-7/8 (48)

STUFFING BOX 80-PF, 80-S, 80-D

MOTOR FRAME	A	B	E (Max)	G	H (Max)	125# ANSI			250# ANSI			R	VFD	Rv	Zv	W	Hv	Xv
						J	N	P	J	N	P							
254	18 (457)	36 (914)	24-1/8 (613)	10-1/4 (260)	42-1/2 (1080)	11-3/4 (298)	8	7/8 (22)	13 (330)	12	7/8 (22)	17 (432)	A5	14-17/32 (369)	13-17/64 (337)	9-1/2 (241)	42-1/2 (1079)	4-47/64 (120)
256	18 (457)	36 (914)	24-1/8 (613)	10-1/4 (260)	42-1/2 (1080)	11-3/4 (298)	8	7/8 (22)	13 (330)	12	7/8 (22)	17 (432)	A5	14-17/32 (369)	13-17/64 (337)	9-1/2 (241)	42-1/2 (1079)	4-47/64 (120)
													B1	16-53/64 (427)	14-59/64 (379)	9-1/2 (241)	44-7/8 (1140)	3-5/64 (78)
284	18 (457)	36 (914)	23-5/8 (600)	10-1/4 (260)	42 (1067)	11-3/4 (298)	8	7/8 (22)	13 (330)	12	7/8 (22)	16-1/8 (410)	B1	17-37/64 (446)	15-29/64 (392)	9-1/2 (241)	44-1/4 (1124)	2-35/64 (65)
286	18 (457)	36 (914)	25-1/8 (638)	10-1/4 (260)	43-1/2 (1105)	11-3/4 (298)	8	7/8 (22)	13 (330)	12	7/8 (22)	16-1/8 (410)	B1	17-37/64 (446)	15-29/64 (392)	9-1/2 (241)	45-3/4 (1162)	2-35/64 (65)
													B2	17-37/64 (446)	15-29/64 (392)	9-1/2 (241)	50-13/64 (1275)	2-35/64 (65)
													C1	19-37/64 (497)	17-5/8 (448)	12-3/32 (307)	52-39/64 (1336)	3/8 (10)
324	18 (457)	36 (914)	26 (660)	10-1/4 (260)	44-3/8 (1127)	11-3/4 (298)	8	7/8 (22)	13 (330)	12	7/8 (22)	18-3/4 (476)	B2	18-37/64 (472)	16-5/32 (410)	9-1/2 (241)	49-35/64 (1259)	1-27/32 (47)
													C1	20-37/64 (523)	18-21/64 (465)	12-3/32 (307)	49-57/64 (1267)	21/64 (8)
326	18 (457)	36 (914)	26 (660)	10-1/4 (260)	44-3/8 (1127)	11-3/4 (298)	8	7/8 (22)	13 (330)	12	7/8 (22)	18-3/4 (476)	C1	20-37/64 (523)	18-21/64 (465)	12-3/32 (307)	49-57/64 (1267)	21/64 (8)
													C2	21-37/64 (548)	19-7/8 (505)	14-19/32 (371)	54-29/64 (1383)	1-7/8 (48)

Xylem Inc.
8200 N. Austin Avenue
Morton Grove, IL 60053
Phone: (847)966-3700
Fax: (847)965-8379
www.bellgossett.com

