

JOB:	REPRESENTATIVE:	
UNIT TAG:	ORDER NO.:	DATE:
ENGINEER:	SUBMITTED BY:	DATE:
CONTRACTOR:	APPROVED BY:	DATE:

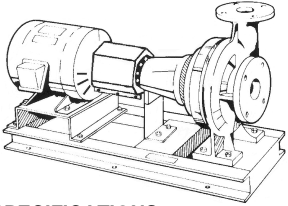

8GB

Series e-1510

Centrifugal Pumps - Base Mounted

SPECIFICATIONS

FLOW _____ HEAD _____

HP _____ RPM _____

VOLTS _____

CYCLE _____ PHASE _____

ENCLOSURE _____

APPROX. WEIGHT _____

SPECIALS _____

MATERIALS OF CONSTRUCTION

Stainless Steel Fitted

FEATURES

- i-ALERT™ Condition Monitor
- ANSI/OSHA Coupling Guard
- Center Drop Out Spacer Coupling
- Fabricated Heavy Duty Baseplate

MAXIMUM WORKING PRESSURE

175 psi (12 bar) W.P.
w/ 125# ANSI flange drilling

TYPE OF SEAL

- Standard Seal (Buna-Carbon/Ceramic)
- F Standard Seal w/ Flush Line (Buna-Carbon/Ceramic)
- S Stuffing Box Construction w/ Flushed Mechanical Single Seal (EPR-Tungsten Carbide/Carbon)
- PF Stuffing Box Construction w/ Packing (Graphite Impregnated Teflon)

Note: Equipped with NEOPRENE coupling

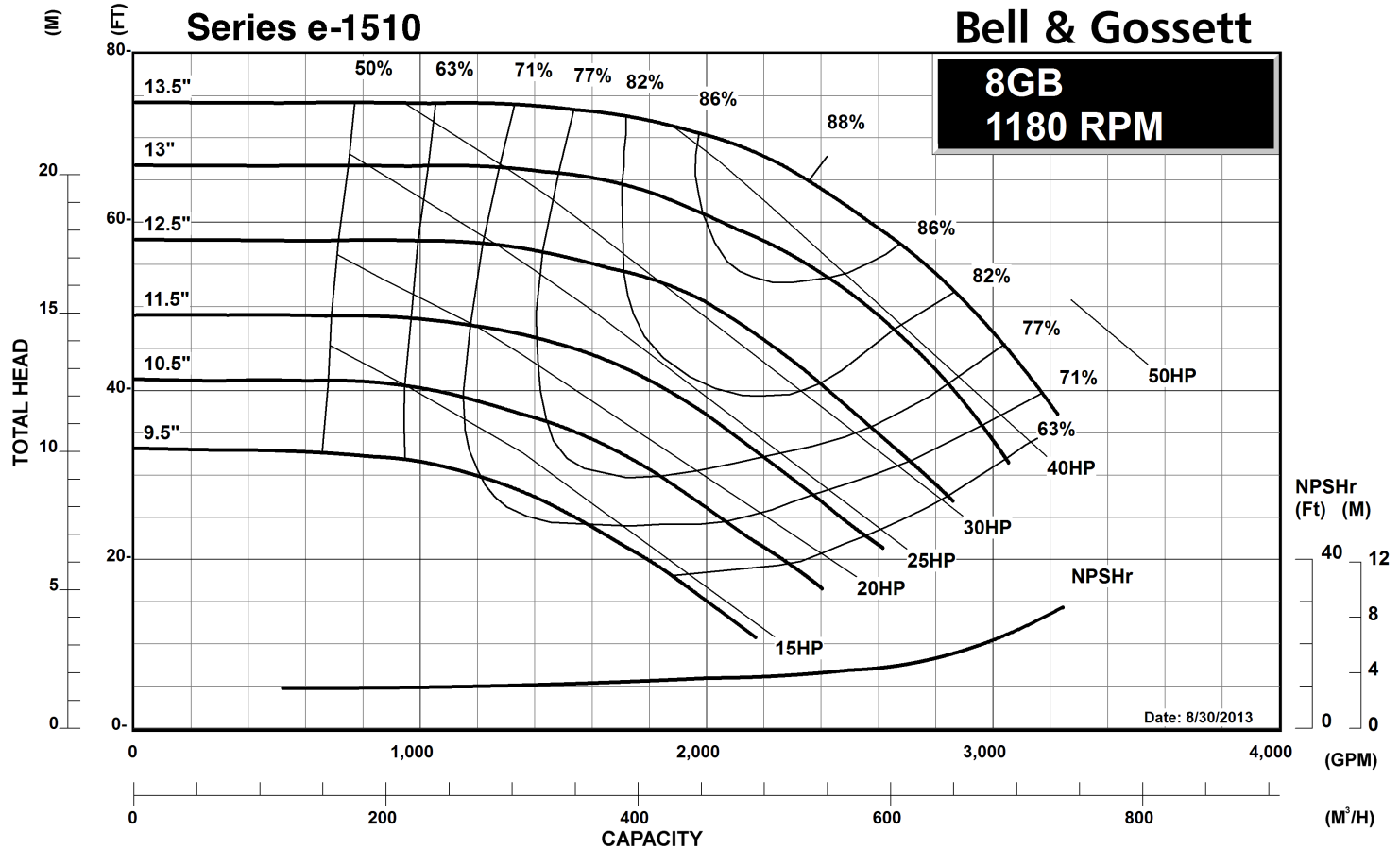

JOB: UNIT TAG: ENGINEER: CONTRACTOR:	REPRESENTATIVE: ORDER NO. SUBMITTED BY: APPROVED BY:	DATE: DATE: DATE:
---	---	--

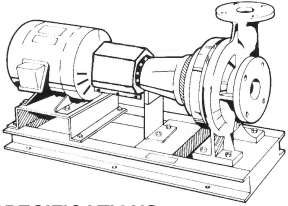

8GB

Series e-1510

Centrifugal Pumps - Base Mounted

SPECIFICATIONS

FLOW _____ HEAD _____

HP _____ RPM _____

VOLTS _____

CYCLE _____ PHASE _____

ENCLOSURE _____

APPROX. WEIGHT _____

SPECIALS _____

MATERIALS OF CONSTRUCTION

Stainless Steel Fitted

FEATURES

- i-ALERT™ Condition Monitor
- ANSI/OSHA Coupling Guard
- Center Drop Out Spacer Coupling
- Fabricated Heavy Duty Baseplate

MAXIMUM WORKING PRESSURE

175 psi (12 bar) W.P.
w/ 125# ANSI flange drilling

TYPE OF SEAL

- Standard Seal (Buna-Carbon/Ceramic)
- F Standard Seal w/ Flush Line (Buna-Carbon/Ceramic)
- S Stuffing Box Construction w/ Flushed Mechanical Single Seal (EPR-Tungsten Carbide/Carbon)
- PF Stuffing Box Construction w/ Packing (Graphite Impregnated Teflon)

Note: Equipped with NEOPRENE coupling

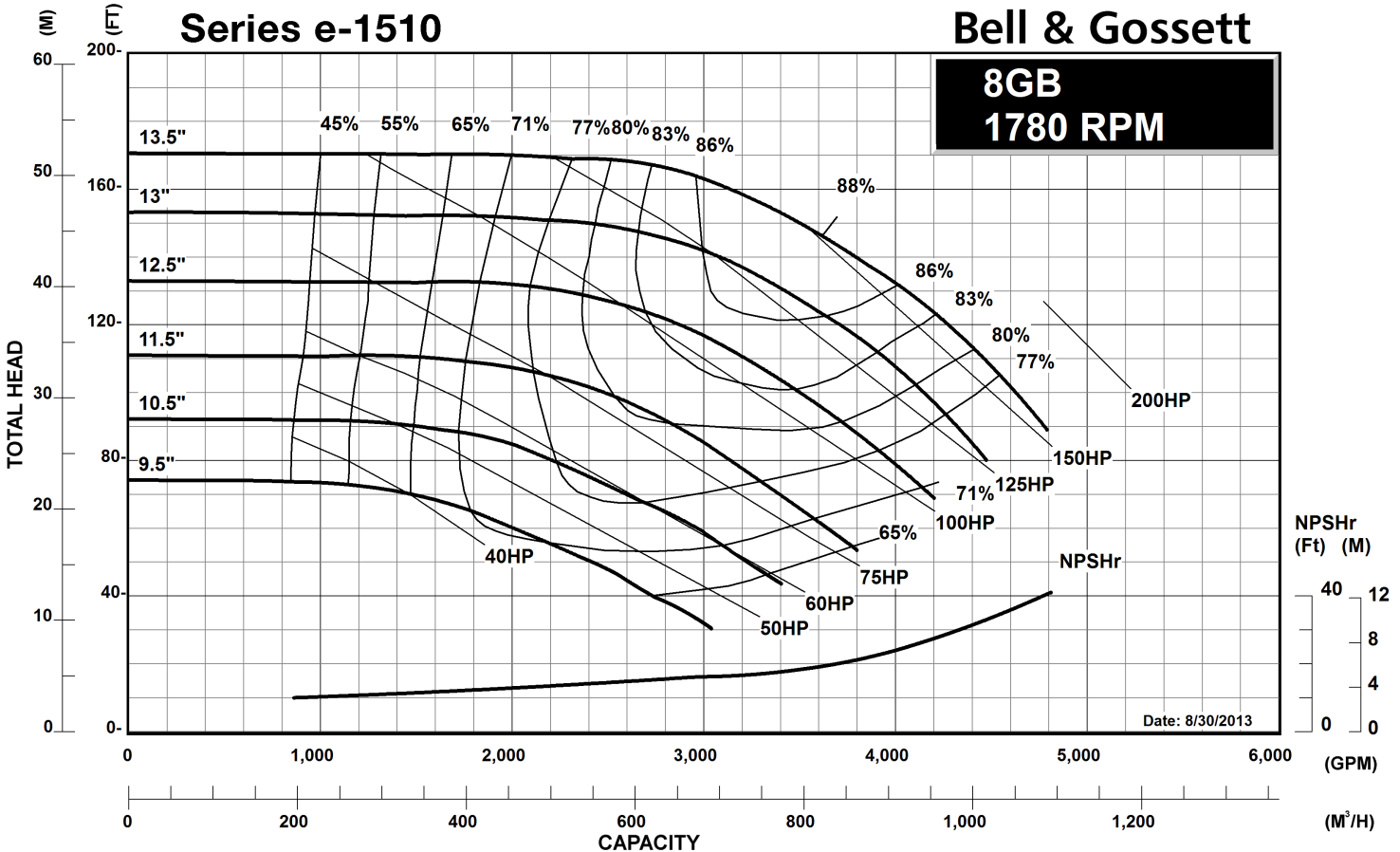

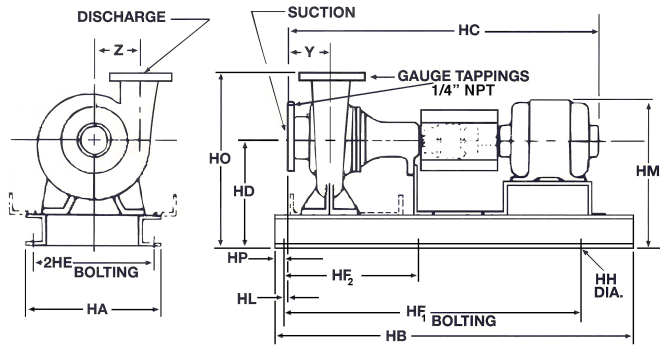

FLANGE DIMENSIONS IN INCHES (MM)			
..	SIZE	THICKNESS	O.D.
Discharge	8" (203)	1.69" (43)	15" (381)
Suction	10" (256)	1.95" (50)	17.5" (444)

FLANGES ARE:125# ANSI - STANDARD

DIMENSIONS - Inches (mm)

STANDARD SEAL

MOTOR FRAME	HA	HB	HC MAX	HD	2HE	HF1	HF2	HH	HL	HM MAX	HO	HP	Y	Z
"L" FRAME														
256T	28.00 (711)	70.00 (1778)	50.34 (1279)	18.38 (467)	26.00 (660)	33.75 (857)	67.50 (1751)	1.00 (25)	0.44 (11)	25.25 (641)	33.07 (840)	1.25 (32)	7.01 (178)	11.25 (286)
284T	28.00 (711)	70.00 (1778)	51.34 (1304)	18.38 (467)	26.00 (660)	33.75 (857)	67.50 (1751)	1.00 (25)	0.44 (11)	26.38 (670)	33.07 (840)	1.25 (32)	7.01 (178)	11.25 (286)
286T	28.00 (711)	70.00 (1778)	52.84 (1342)	18.38 (467)	26.00 (660)	33.75 (857)	67.50 (1751)	1.00 (25)	0.44 (11)	26.38 (670)	33.07 (840)	1.25 (32)	7.01 (178)	11.25 (286)
324T	28.00 (711)	70.00 (1778)	54.84 (1393)	18.38 (467)	26.00 (660)	33.75 (857)	67.50 (1751)	1.00 (25)	0.44 (11)	27.50 (699)	33.07 (840)	1.25 (32)	7.01 (178)	11.25 (286)
326T	28.00 (711)	70.00 (1778)	56.34 (1431)	18.38 (467)	26.00 (660)	33.75 (857)	67.50 (1751)	1.00 (25)	0.44 (11)	27.50 (699)	33.07 (840)	1.25 (32)	7.01 (178)	11.25 (286)
364T	28.00 (711)	70.00 (1778)	58.54 (1487)	18.38 (467)	26.00 (660)	33.75 (857)	67.50 (1751)	1.00 (25)	0.44 (11)	28.63 (727)	33.07 (840)	1.25 (32)	7.01 (178)	11.25 (286)
365T	28.00 (711)	70.00 (1778)	59.21 (1504)	18.38 (467)	26.00 (660)	33.75 (857)	67.50 (1751)	1.00 (25)	0.44 (11)	28.63 (727)	33.07 (840)	1.25 (32)	7.01 (178)	11.25 (286)
404TS	28.00 (711)	70.00 (1778)	59.34 (1507)	18.38 (467)	26.00 (660)	33.75 (857)	67.50 (1751)	1.00 (25)	0.44 (11)	30.25 (768)	33.07 (840)	1.25 (32)	7.01 (178)	11.25 (286)
405TS	28.00 (711)	70.00 (1778)	60.09 (1526)	18.38 (467)	26.00 (660)	33.75 (857)	67.50 (1751)	1.00 (25)	0.44 (11)	31.88 (810)	33.07 (840)	1.25 (32)	7.01 (178)	11.25 (286)
"XL" FRAME														
324T	28.00 (711)	70.00 (1778)	59.59 (1514)	18.38 (467)	26.00 (660)	33.75 (857)	67.50 (1751)	1.00 (25)	0.44 (11)	26.63 (676)	33.07 (840)	1.25 (32)	7.01 (178)	11.25 (286)
326T	28.00 (711)	70.00 (1778)	61.02 (1550)	18.38 (467)	26.00 (660)	33.75 (857)	67.50 (1751)	1.00 (25)	0.44 (11)	26.63 (676)	33.07 (840)	1.25 (32)	7.01 (178)	11.25 (286)
364TS	28.00 (711)	70.00 (1778)	63.27 (1607)	18.38 (467)	26.00 (660)	33.75 (857)	67.50 (1751)	1.00 (25)	0.44 (11)	27.50 (699)	33.07 (840)	1.25 (32)	7.01 (178)	11.25 (286)
365TS	28.00 (711)	70.00 (1778)	63.21 (1606)	18.38 (467)	26.00 (660)	33.75 (857)	67.50 (1751)	1.00 (25)	0.44 (11)	28.63 (727)	33.07 (840)	1.25 (32)	7.01 (178)	11.25 (286)
404TS	28.00 (711)	70.00 (1778)	65.46 (1663)	18.38 (467)	26.00 (660)	33.75 (857)	67.50 (1751)	1.00 (25)	0.44 (11)	30.25 (768)	33.07 (840)	1.25 (32)	7.01 (178)	11.25 (286)
405TS	28.00 (711)	70.00 (1778)	66.96 (1701)	18.38 (467)	26.00 (660)	33.75 (857)	67.50 (1751)	1.00 (25)	0.44 (11)	30.25 (768)	33.07 (840)	1.25 (32)	7.01 (178)	11.25 (286)
444TS	28.00 (711)	70.00 (1778)	71.34 (1812)	18.38 (467)	26.00 (660)	33.75 (857)	67.50 (1751)	1.00 (25)	0.44 (11)	31.13 (791)	33.07 (840)	1.25 (32)	7.01 (178)	11.25 (286)

Dimensions are subject to change. Not to be used for construction purposes unless certified.
 At 1800 RPM operation and impeller diameters greater than 12.5", "XL" bearing frame required.

Xylem Inc.
 8200 N. Austin Avenue
 Morton Grove, IL 60053
 Phone: (847)966-3700
 Fax: (847)965-8379
 www.bellgossett.com



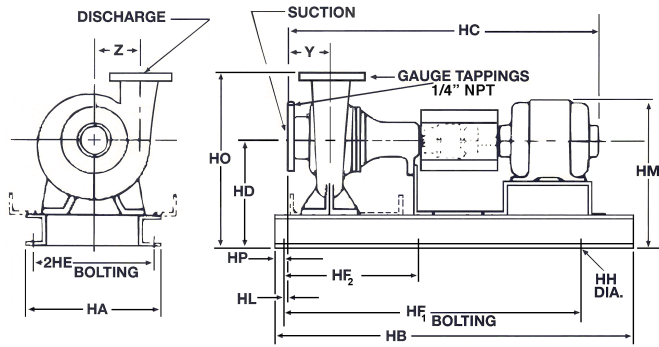

FLANGE DIMENSIONS IN INCHES (MM)			
..	SIZE	THICKNESS	O.D.
Discharge	8" (203)	1.69" (43)	15" (381)
Suction	10" (256)	1.95" (50)	17.5" (444)

FLANGES ARE:125# ANSI - STANDARD

DIMENSIONS - Inches (mm)

STUFFING BOX

MOTOR FRAME	HA	HB	HC MAX	HD	2HE	HF1	HF2	HH	HL	HM MAX	HO	HP	Y	Z
"L" FRAME														
256T	28.00 (711)	70.00 (1778)	52.71 (1339)	18.38 (467)	26.00 (660)	33.75 (857)	67.50 (1751)	1.00 (25)	0.44 (11)	25.25 (641)	33.07 (840)	1.25 (32)	7.01 (178)	11.25 (286)
284T	28.00 (711)	70.00 (1778)	53.71 (1364)	18.38 (467)	26.00 (660)	33.75 (857)	67.50 (1751)	1.00 (25)	0.44 (11)	26.38 (670)	33.07 (840)	1.25 (32)	7.01 (178)	11.25 (286)
286T	28.00 (711)	70.00 (1778)	55.21 (1402)	18.38 (467)	26.00 (660)	33.75 (857)	67.50 (1751)	1.00 (25)	0.44 (11)	26.38 (670)	33.07 (840)	1.25 (32)	7.01 (178)	11.25 (286)
324T	28.00 (711)	70.00 (1778)	57.21 (1453)	18.38 (467)	26.00 (660)	33.75 (857)	67.50 (1751)	1.00 (25)	0.44 (11)	27.50 (699)	33.07 (840)	1.25 (32)	7.01 (178)	11.25 (286)
326T	28.00 (711)	70.00 (1778)	58.71 (1491)	18.38 (467)	26.00 (660)	33.75 (857)	67.50 (1751)	1.00 (25)	0.44 (11)	27.50 (699)	33.07 (840)	1.25 (32)	7.01 (178)	11.25 (286)
364T	28.00 (711)	70.00 (1778)	60.96 (1548)	18.38 (467)	26.00 (660)	33.75 (857)	67.50 (1751)	1.00 (25)	0.44 (11)	28.63 (727)	33.07 (840)	1.25 (32)	7.01 (178)	11.25 (286)
365T	28.00 (711)	70.00 (1778)	61.59 (1564)	18.38 (467)	26.00 (660)	33.75 (857)	67.50 (1751)	1.00 (25)	0.44 (11)	28.63 (727)	33.07 (840)	1.25 (32)	7.01 (178)	11.25 (286)
404TS	28.00 (711)	70.00 (1778)	61.71 (1567)	18.38 (467)	26.00 (660)	33.75 (857)	67.50 (1751)	1.00 (25)	0.44 (11)	30.25 (768)	33.07 (840)	1.25 (32)	7.01 (178)	11.25 (286)
405TS	28.00 (711)	70.00 (1778)	62.71 (1593)	18.38 (467)	26.00 (660)	33.75 (857)	67.50 (1751)	1.00 (25)	0.44 (11)	31.88 (810)	33.07 (840)	1.25 (32)	7.01 (178)	11.25 (286)
"XL" FRAME														
324T	28.00 (711)	70.00 (1778)	63.09 (1602)	18.38 (467)	26.00 (660)	33.75 (857)	67.50 (1751)	1.00 (25)	0.44 (11)	26.63 (676)	33.07 (840)	1.25 (32)	7.01 (178)	11.25 (286)
326T	28.00 (711)	70.00 (1778)	63.09 (1602)	18.38 (467)	26.00 (660)	33.75 (857)	67.50 (1751)	1.00 (25)	0.44 (11)	26.63 (676)	33.07 (840)	1.25 (32)	7.01 (178)	11.25 (286)
364TS	28.00 (711)	70.00 (1778)	63.46 (1612)	18.38 (467)	26.00 (660)	33.75 (857)	67.50 (1751)	1.00 (25)	0.44 (11)	27.50 (699)	33.07 (840)	1.25 (32)	7.01 (178)	11.25 (286)
365TS	28.00 (711)	70.00 (1778)	65.46 (1663)	18.38 (467)	26.00 (660)	33.75 (857)	67.50 (1751)	1.00 (25)	0.44 (11)	28.63 (727)	33.07 (840)	1.25 (32)	7.01 (178)	11.25 (286)
404TS	28.00 (711)	70.00 (1778)	67.71 (1720)	18.38 (467)	26.00 (660)	33.75 (857)	67.50 (1751)	1.00 (25)	0.44 (11)	30.25 (768)	33.07 (840)	1.25 (32)	7.01 (178)	11.25 (286)
405TS	28.00 (711)	70.00 (1778)	69.21 (1758)	18.38 (467)	26.00 (660)	33.75 (857)	67.50 (1751)	1.00 (25)	0.44 (11)	30.25 (768)	33.07 (840)	1.25 (32)	7.01 (178)	11.25 (286)
444TS	28.00 (711)	70.00 (1778)	73.46 (1866)	18.38 (467)	26.00 (660)	33.75 (857)	67.50 (1751)	1.00 (25)	0.44 (11)	31.13 (791)	33.07 (840)	1.25 (32)	7.01 (178)	11.25 (286)

Dimensions are subject to change. Not to be used for construction purposes unless certified.
 At 1800 RPM operation and impeller diameters greater than 12.5", "XL" bearing frame required.

Xylem Inc.
 8200 N. Austin Avenue
 Morton Grove, IL 60053
 Phone: (847)966-3700
 Fax: (847)965-8379
 www.bellgossett.com

