

<p>JOB:</p> <p>UNIT TAG:</p> <p>ENGINEER:</p> <p>CONTRACTOR:</p>	<p>REPRESENTATIVE:</p> <p>ORDER NO.</p> <p>SUBMITTED BY:</p> <p>APPROVED BY:</p>	<p>DATE:</p> <p>DATE:</p> <p>DATE:</p>
---	---	---

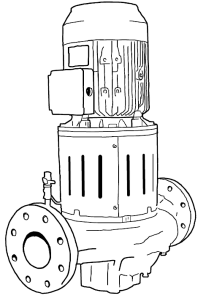

2x2x7

Series 80[®]-SC

Spacer Coupled Vertical
In-Line Mounted Centrifugal Pumps

SPECIFICATIONS

FLOW _____ HEAD _____

HP _____ RPM _____

VOLTS _____

CYCLE _____ PHASE _____

ENCLOSURE _____

APPROX. WEIGHT _____

SPECIALS _____

MATERIALS OF CONSTRUCTION

BRONZE FITTED ALL IRON

WORKING PRESSURE

175 psi (12 bar) W.P. with 125# ANSI flange drilling

250 psi (17 bar) W.P. with 250# ANSI flange drilling

TYPE OF SEAL

STANDARD SEAL - Inside Unitized with flush line (EPR/Carbon-Ceramic)
Temp. range -20° to +250°F. (-29° to 121°C)
Maximum pressure is 175 psi (12 bar)

OPTIONAL SEAL - Inside Unitized with flush line (EPR/Carbon-Tungsten Carbide)
Temp. range -20° to +250°F. (-29° to 121°C)
Maximum pressure is 250 psi (17 bar)

OPTIONAL SEAL - Outside Type "8B2"; with flush line (EPR/Carbon-Tungsten Carbide)
Temp. range -20° to +250°F. (-29° to 121°C)
Maximum pressure is 175 psi (12 bar)

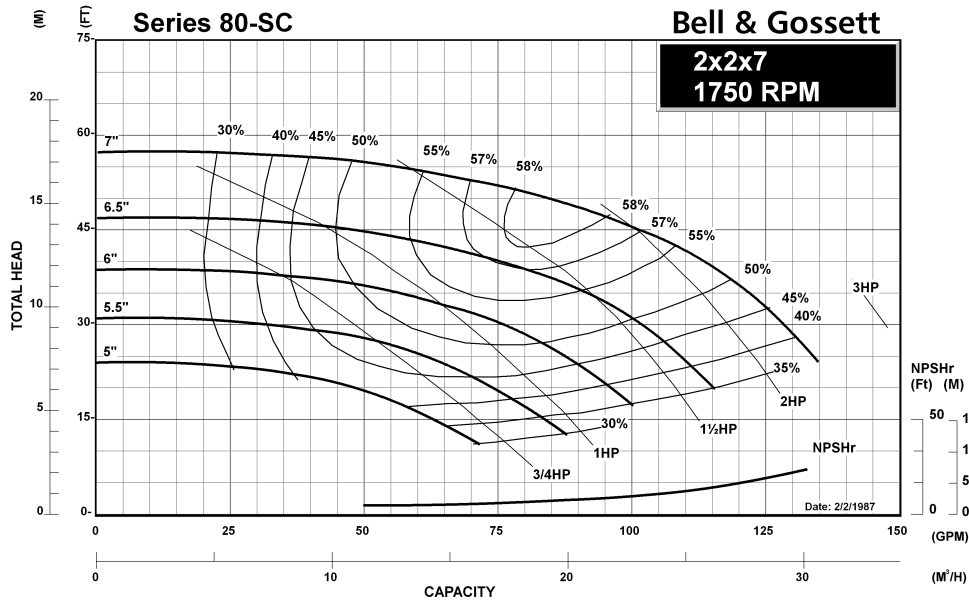

<p>JOB:</p> <p>UNIT TAG:</p> <p>ENGINEER:</p> <p>CONTRACTOR:</p>	<p>REPRESENTATIVE:</p> <p>ORDER NO.</p> <p>SUBMITTED BY:</p> <p>APPROVED BY:</p>	<p>DATE:</p> <p>DATE:</p> <p>DATE:</p>
---	---	---

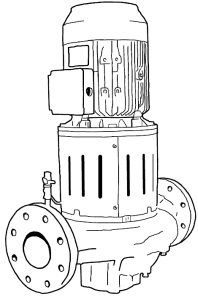

2x2x7

Series 80[®]-SC

Spacer Coupled Vertical
In-Line Mounted Centrifugal Pumps

SPECIFICATIONS

FLOW _____ HEAD _____

HP _____ RPM _____

VOLTS _____

CYCLE _____ PHASE _____

ENCLOSURE _____

APPROX. WEIGHT _____

SPECIALS _____

MATERIALS OF CONSTRUCTION

BRONZE FITTED ALL IRON

WORKING PRESSURE

175 psi (12 bar) W.P. with 125# ANSI flange drilling

250 psi (17 bar) W.P. with 250# ANSI flange drilling

TYPE OF SEAL

STANDARD SEAL - Inside Unitized with flush line (EPR/Carbon-Ceramic)
Temp. range -20° to +250°F. (-29° to 121°C)
Maximum pressure is 175 psi (12 bar)

OPTIONAL SEAL - Inside Unitized with flush line (EPR/Carbon-Tungsten Carbide)
Temp. range -20° to +250°F. (-29° to 121°C)
Maximum pressure is 250 psi (17 bar)

OPTIONAL SEAL - Outside Type "8B2"; with flush line (EPR/Carbon-Tungsten Carbide)
Temp. range -20° to +250°F. (-29° to 121°C)
Maximum pressure is 175 psi (12 bar)

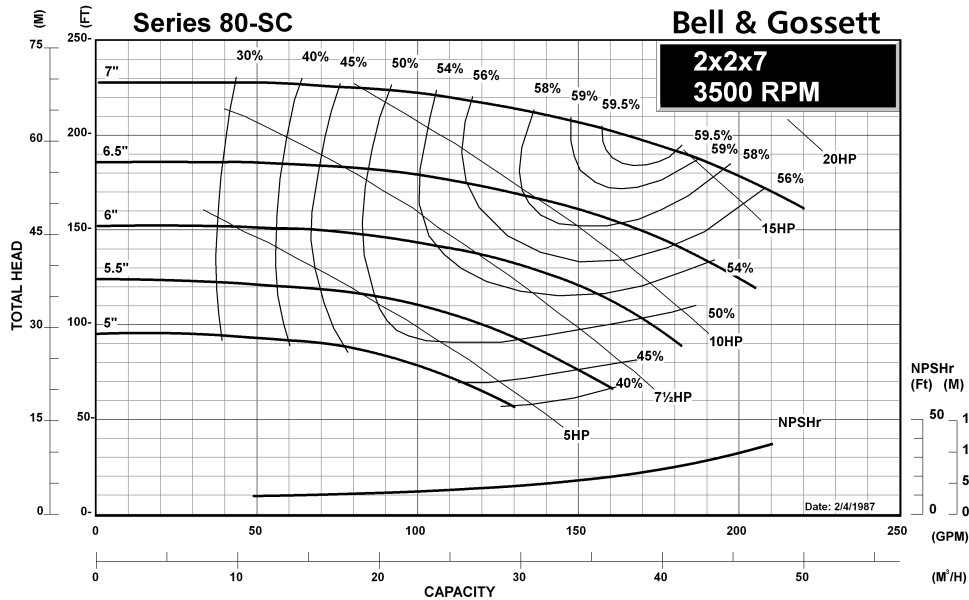

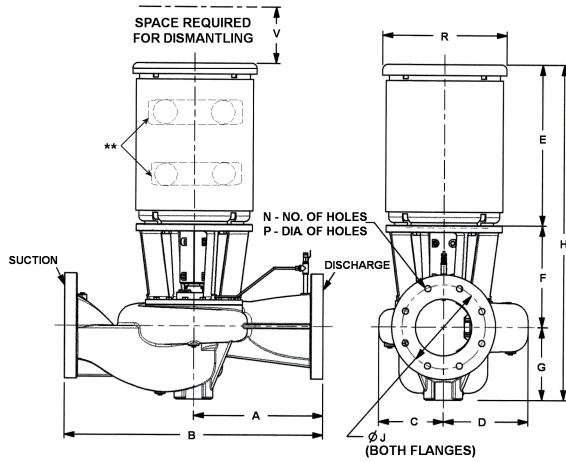

FLANGE DIMENSIONS IN INCHES (MM)			
	SIZE	THICKNESS	O.D.
Discharge	2"	7/8 (22)	6-1/4 (159)
Suction	2"	7/8 (22)	6-1/4 (159)

**VOLUTE BASE RING TAPPED FOR
1-1/2" - 125# ANSI FLANGE TO SUPPORT PUMP**

** Motor may be supplied with feet

DIMENSIONS - Inches (mm)

TC SHAFT MOTORS

MOTOR FRAME	A	B	C	D	G	F	E	H	125# ANSI			250# ANSI			R	V (Min)
									J	N	P	J	N	P		
182TC	8-1/2 (216)	17 (432)	4-3/4 (121)	5-1/4 (133)	4-7/8 (124)	11-3/4 (298)	12-1/4 (311)	28-7/8 (733)	4-3/4 (121)	4	3/4 (19)	5 (127)	8	3/4 (19)	8-3/4 (222)	4 (102)
184TC	8-1/2 (216)	17 (432)	4-3/4 (121)	5-1/4 (133)	4-7/8 (124)	11-3/4 (298)	13-1/4 (337)	29-7/8 (759)	4-3/4 (121)	4	3/4 (19)	5 (127)	8	3/4 (19)	8-3/4 (222)	4 (102)
213TC	8-1/2 (216)	17 (432)	4-3/4 (121)	5-1/4 (133)	4-7/8 (124)	11-3/4 (298)	14-7/8 (378)	31-9/16 (802)	4-3/4 (121)	4	3/4 (19)	5 (127)	8	3/4 (19)	10-5/8 (270)	4 (102)
215TC	8-1/2 (216)	17 (432)	4-3/4 (121)	5-1/4 (133)	4-7/8 (124)	11-3/4 (298)	14-7/8 (378)	31-9/16 (802)	4-3/4 (121)	4	3/4 (19)	5 (127)	8	3/4 (19)	10-5/8 (270)	4 (102)
254TC	8-1/2 (216)	17 (432)	4-3/4 (121)	5-1/4 (133)	4-7/8 (124)	11-3/4 (298)	19-7/16 (494)	36-1/8 (918)	4-3/4 (121)	4	3/4 (19)	5 (127)	8	3/4 (19)	12-5/16 (313)	4 (102)

HP SHAFT MOTORS

MOTOR FRAME	A	B	C	D	G	F	E	H	125# ANSI			250# ANSI			R	V (Min)
									J	N	P	J	N	P		
143HP	8-1/2 (216)	17 (432)	4-3/4 (121)	5-1/4 (133)	4-7/8 (124)	11-3/4 (298)	11-13/16 (300)	28-7/16 (722)	4-3/4 (121)	4	3/4 (19)	5 (127)	8	3/4 (19)	7-1/16 (179)	4 (102)
145HP	8-1/2 (216)	17 (432)	4-3/4 (121)	5-1/4 (133)	4-7/8 (124)	11-3/4 (298)	12-13/16 (325)	29-7/16 (748)	4-3/4 (121)	4	3/4 (19)	5 (127)	8	3/4 (19)	7-1/16 (179)	4 (102)
182HP	8-1/2 (216)	17 (432)	4-3/4 (121)	5-1/4 (133)	4-7/8 (124)	11-3/4 (298)	13-7/8 (352)	30-9/16 (776)	4-3/4 (121)	4	3/4 (19)	5 (127)	8	3/4 (19)	8-3/4 (222)	4 (102)
184HP	8-1/2 (216)	17 (432)	4-3/4 (121)	5-1/4 (133)	4-7/8 (124)	11-3/4 (298)	14-7/8 (378)	31-9/16 (802)	4-3/4 (121)	4	3/4 (19)	5 (127)	8	3/4 (19)	8-3/4 (222)	4 (102)
213HP	8-1/2 (216)	17 (432)	4-3/4 (121)	5-1/4 (133)	4-7/8 (124)	11-3/4 (298)	17-1/4 (438)	33-15/16 (862)	4-3/4 (121)	4	3/4 (19)	5 (127)	8	3/4 (19)	10-5/8 (270)	4 (102)
215HP	8-1/2 (216)	17 (432)	4-3/4 (121)	5-1/4 (133)	4-7/8 (124)	11-3/4 (298)	18-3/4 (476)	35-7/16 (900)	4-3/4 (121)	4	3/4 (19)	5 (127)	8	3/4 (19)	10-5/8 (270)	4 (102)
254HP	8-1/2 (216)	17 (432)	4-3/4 (121)	5-1/4 (133)	4-7/8 (124)	11-3/4 (298)	22-3/8 (568)	39(991)	4-3/4 (121)	4	3/4 (19)	5 (127)	8	3/4 (19)	12-5/16 (313)	4 (102)

IEC SHAFT MOTORS

MOTOR FRAME	A	B	C	D	G	F	E	H	125# ANSI			250# ANSI			R	V (Min)
									J	N	P	J	N	P		
80	8-1/2 (216)	17 (432)	4-3/4 (121)	5-1/4 (133)	4-7/8 (124)	11-3/4 (298)	9-15/16 (252)	26-5/8 (676)	4-3/4 (121)	4	3/4 (19)	5 (127)	8	3/4 (19)	6-7/8 (175)	4 (102)
90	8-1/2 (216)	17 (432)	4-3/4 (121)	5-1/4 (133)	4-7/8 (124)	11-3/4 (298)	11-5/8 (295)	28-1/4 (718)	4-3/4 (121)	4	3/4 (19)	5 (127)	8	3/4 (19)	7-1/2 (190)	4 (102)
100L	8-1/2 (216)	17 (432)	4-3/4 (121)	5-1/4 (133)	4-7/8 (124)	11-3/4 (298)	12-11/16 (322)	29-5/16 (745)	4-3/4 (121)	4	3/4 (19)	5 (127)	8	3/4 (19)	8-1/4 (210)	4 (102)
112M	8-1/2 (216)	17 (432)	4-3/4 (121)	5-1/4 (133)	4-7/8 (124)	11-3/4 (298)	13-9/16 (344)	30-1/4 (768)	4-3/4 (121)	4	3/4 (19)	5 (127)	8	3/4 (19)	9-5/16 (237)	4 (102)
132	8-1/2 (216)	17 (432)	4-3/4 (121)	5-1/4 (133)	4-7/8 (124)	11-3/4 (298)	17-1/8 (435)	33-3/4 (857)	4-3/4 (121)	4	3/4 (19)	5 (127)	8	3/4 (19)	10-13/16 (275)	4 (102)

Dimensions are subject to change. Not to be used for construction purposes unless certified.

NOTE: For TEFC add 1-1/2" to dimensions E & H.

Xylem Inc.
8200 N. Austin Avenue
Morton Grove, IL 60053
Phone: (847)966-3700
Fax: (847)965-8379
www.bellgossett.com



JOB: UNIT TAG: ENGINEER: CONTRACTOR:	REPRESENTATIVE: ORDER NO. SUBMITTED BY: APPROVED BY:	DATE: DATE: DATE:
---	---	--

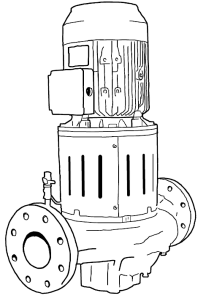

2x2x7

Series 80[®]-SC

Spacer Coupled Vertical In-Line Mounted Centrifugal Pumps

SPECIFICATIONS

FLOW _____ HEAD _____

HP _____ RPM _____

VOLTS _____

CYCLE _____ PHASE _____

ENCLOSURE _____

APPROX. WEIGHT _____

SPECIALS _____

MATERIALS OF CONSTRUCTION

BRONZE FITTED ALL IRON

WORKING PRESSURE

175 psi (12 bar) W.P. with 125# ANSI flange drilling

250 psi (17 bar) W.P. with 250# ANSI flange drilling

TYPE OF SEAL

STANDARD SEAL - Inside Unitized with flush line (EPR/Carbon-Ceramic)
Temp. range -20° to +250°F. (-29° to 121°C)
Maximum pressure is 175 psi (12 bar)

OPTIONAL SEAL - Inside Unitized with flush line (EPR/Carbon-Tungsten Carbide)
Temp. range -20° to +250°F. (-29° to 121°C)
Maximum pressure is 250 psi (17 bar)

OPTIONAL SEAL - Outside Type "8B2"; with flush line (EPR/Carbon-Tungsten Carbide)
Temp. range -20° to +250°F. (-29° to 121°C)
Maximum pressure is 175 psi (12 bar)

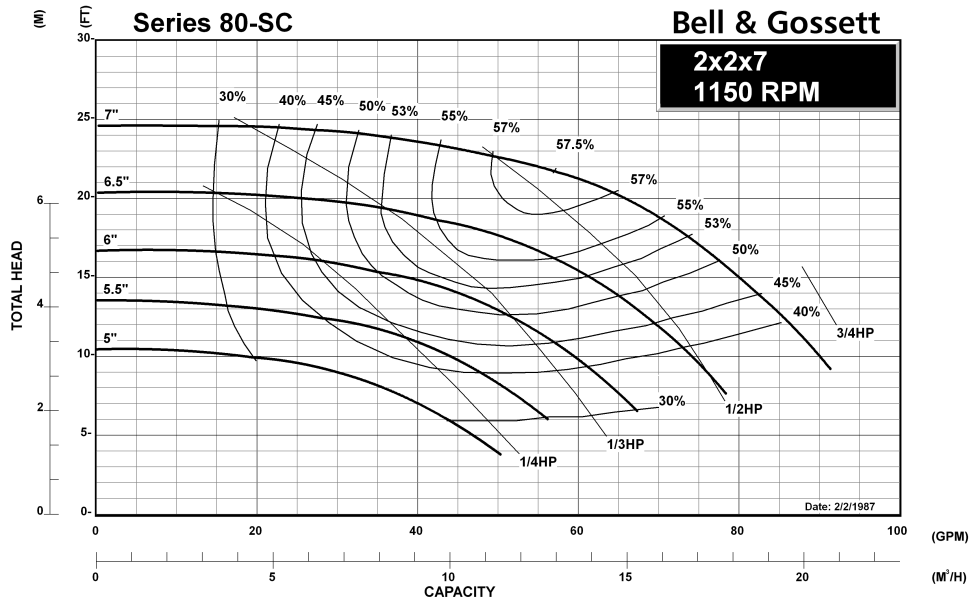

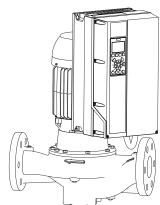

2x2x7 Series 80SC[®]

In-Line Mounted Centrifugal Pumps
With Optional Integrated Technolog[®] featuring Sensorless Control

TECHNOLOGIC STANDARD FEATURES	
CONTROL METHOD	Constant Pressure, Linear Control Curve, Quadratic Control Curve Factory configured for sensorless operation standard. Field configurable for use with a wired transducer.
ENCLOSURE	IP55 / NEMA 12 / UL type 12
POWER DISCONNECT SWITCH	Included standard. Fused Disconnect Switch optional.
EMI/RFI CONTROL	Integrated filter to meet EN62800-3.
HARMONIC SUPPRESSION	Integrated non-saturating dual DC link reactors provide better harmonic performance than a 5% AC line reactor.
COOLING	Fan-cooled through temperature controlled and easy replacement.
AMBIENT TEMPERATURE RATING	14°F to 113°F (-10°C to 45°C)
COMMUNICATION PROTOCOLS	BACnet, Modbus RTU, N2 Metasys, FLN Apogee
ANALOG INPUTS	2 configurable for either voltage (0 to 10VDC) or current(0/4 to 20mA)
ANALOG OUTPUTS	1 (0/4 to 20mA) up to 500 ohm load accurate to 1% of full scale
DIGITAL INPUTS	4 (0 to 24VDC), NPN or PNP, 0 to 24VDC, on 5 msec scan interval, Up to 2 can be configured as pulse inputs.
DIGITAL OUTPUTS	2 (0 to 24VDC), 40mA max current, configurable as pulse outputs.
RELAY OUTPUTS	2 programmable, 240VAC or 400VAC up to 2 A

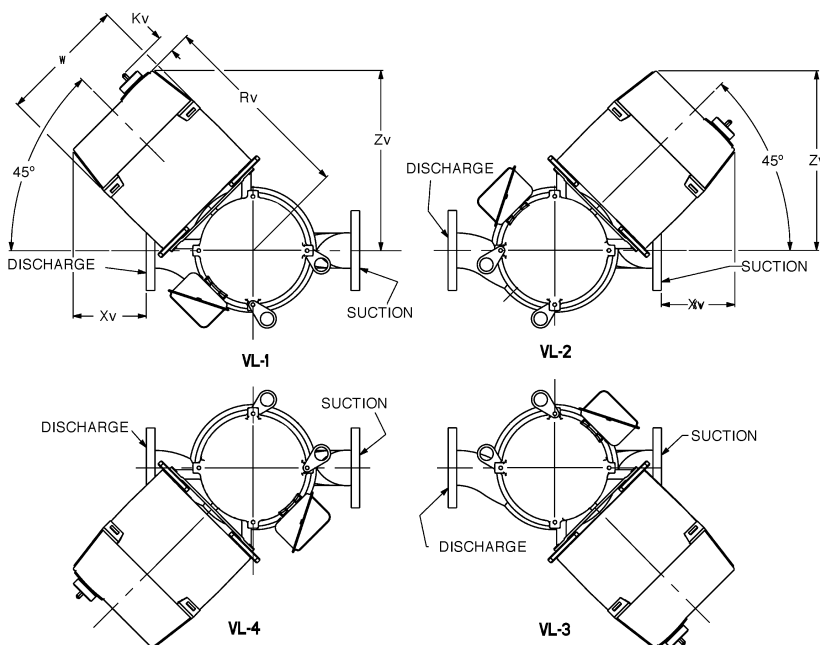
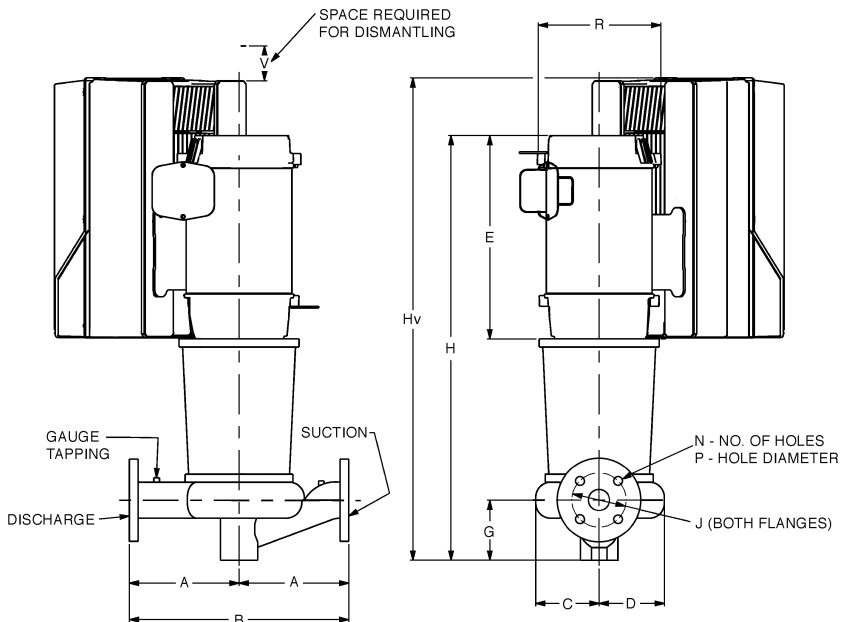

Xylem Inc.
8200 N. Austin Avenue
Morton Grove, IL 60053
Phone: (847)966-3700
Fax: (847)965-8379
www.bellgossett.com



Bell & Gossett is a trademark of Xylem Inc. or one of its subsidiaries.
© 2013 Xylem Inc.

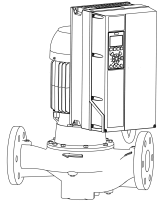

2x2x7 Series 80-SC[®]

In-Line Mounted Centrifugal Pumps
With Optional Integrated Technologic[®] featuring Sensorless Control

DIMENSIONS – Inches (mm)

TC SHAFT MOTORS

MOTOR FRAME	A	B	G	E	125# ANSI			250# ANSI			R	V (Min)	VFD	Rv	Zv	W	Hv	Xv	Kv
					J	N	P	J	N	P									
182TC	8-1/2 (216)	17 (432)	4-7/8 (124)	12-1/4 (311)	4-3/4 (121)	4	3/4 (19)	5 (127)	8	3/4 (19)	8-3/4 (222)	4 (102)	A5	12-25/32 (324)	12-1/32 (306)	9-1/2 (241)	31-21/32 (804)	3-17/32 (90)	1-1/2 (38.10)
184TC	8-1/2 (216)	17 (432)	4-7/8 (124)	13-1/4 (337)	4-3/4 (121)	4	3/4 (19)	5 (127)	8	3/4 (19)	8-3/4 (222)	4 (102)	A5	12-25/32 (324)	12-1/32 (306)	9-1/2 (241)	32-21/32 (829)	3-17/32 (90)	1-1/2 (38.10)
													B1	15-5/64 (383)	13-11/16 (348)	9-1/2 (241)	33-23/32 (856)	5-3/16 (132)	1-13/16 (45.72)
213TC	8-1/2 (216)	17 (432)	4-7/8 (124)	14-7/8 (378)	4-3/4 (121)	4	3/4 (19)	5 (127)	8	3/4 (19)	10-5/8 (270)	4 (102)	A5	13-17/32 (344)	12-9/16 (319)	9-1/2 (241)	31-9/16 (802)	4-1/16 (103)	1-1/2 (38.10)
													B1	15-53/64 (402)	14-7/32 (361)	9-1/2 (241)	33 (838)	5-23/32 (145)	1-13/16 (45.72)
215TC	8-1/2 (216)	17 (432)	4-7/8 (124)	14-7/8 (378)	4-3/4 (121)	4	3/4 (19)	5 (127)	8	3/4 (19)	10-5/8 (270)	4 (102)	A5	13-17/32 (344)	12-9/16 (319)	9-1/2 (241)	31-9/16 (802)	4-1/16 (103)	1-1/2 (38.10)
													B1	15-53/64 (402)	14-7/32 (361)	9-1/2 (241)	32-63/64 (838)	5-23/32 (145)	1-13/16 (45.72)
254TC	8-1/2 (216)	17 (432)	4-7/8 (124)	19-7/16 (494)	4-3/4 (121)	4	3/4 (19)	5 (127)	8	3/4 (19)	12-5/16 (313)	4 (102)	B1	16-53/64 (427)	14-59/64 (379)	9-1/2 (241)	38-11/64 (970)	6-27/64 (163)	1-13/16 (45.72)
													B2	16-53/64 (427)	14-59/64 (379)	9-1/2 (241)	42-41/64 (1083)	6-27/64 (163)	1-11/16 (43.18)

Xylem Inc.
8200 N. Austin Avenue
Morton Grove, IL 60053
Phone: (847)966-3700
Fax: (847)965-8379
www.bellgossett.com

xylem
Let's Solve Water

Bell & Gossett is a trademark of Xylem Inc. or one of its subsidiaries.
© 2013 Xylem Inc.