

SERIES 4280 | END SUCTION MOTOR MOUNTED CLOSED-COUPLED | 4 × 3 × 10 | SUBMITTAL

File No: 42.70
Date: SEPTEMBER 10, 2012
Supersedes: 42.70
Date: DECEMBER 15, 2010

Job: _____ Representative: _____
 _____ Order no: _____ Date: _____
 Engineer: _____ Submitted by: _____ Date: _____
 Contractor: _____ Approved by: _____ Date: _____

PUMP DESIGN DATA

No. of pumps: _____ Tag: _____
 Capacity: _____ USgpm (L/s) Head: _____ ft (m)
 Liquid: _____ Viscosity: _____
 Temperature: _____ °F (°C) Specific gravity: _____
 Suction: 4" (100mm) Flanged
 Discharge: 3" (75mm) Flanged

MOTOR DESIGN DATA

HP: _____ RPM: _____ Frame size: _____ Enclosure: _____
 Volts: _____ Hertz: 60 Hz Phase: 3
 Efficiency: Energy EFF 12.11 NEMA premium 12.12

MATERIALS OF CONSTRUCTION

ANSI FLANGE RATING	ANSI 125	ANSI 250
Construction	<input type="checkbox"/> BF	<input type="checkbox"/> DBF
Casing	Cast iron	Ductile iron
Adapter	Cast iron	Ductile iron

Impeller: Bronze

Gasket: Confined non-asbestos fiber

Shaft: Carbon steel

Shaft sleeve: Bronze

MAXIMUM PUMP OPERATING CONDITIONS

ANSI 125

175 psig at 150°F (12 bars at 65°C)
 140 psig at 250°F (10 bars at 121°C)

ANSI 250

300 psig at 150°F (20 bars at 65°C)
 250 psig at 250°F (17 bars at 121°C)

- Tolerance of ±0.125" (±3 mm) should be used
- See performance curves on page 3
- For exact installation, data please write factory for certified dimensions
- Pump equipped with casing drain plug and ¼" NPT suction and discharge gauge ports

MECHANICAL SEAL DATA

Seal type: 2A **Stationary seat:** Silicone carbide
Secondary seal: EPDM **Rotating hardware:** Stainless steel
Spring: Stainless steel

OPTIONAL EQUIPMENT

FLUID TYPE	ALL GLYCOLS > 30% WT CONC		ALL OTHER NON-POTABLE FLUIDS		POTABLE (DRINKING) WATER	
	up to 200°F (93°C)	over 200°F (93°C)	up to 200°F (93°C)	over 200°F (93°C)	up to 200°F (93°C)	over 200°F (93°C)
Temperature	up to 200°F (93°C)	over 200°F (93°C)	up to 200°F (93°C)	over 200°F (93°C)	up to 200°F (93°C)	over 200°F (93°C)
Rotating face	Silicone carbide		Resin bonded carbon	Antimony loaded carbon	Resin bonded carbon	
Seat elastomer	EPDM (L-cup)	EPDM (O-ring)	EPDM (L-cup)	EPDM (O-ring)	EPDM (L-cup)	EPDM (O-ring)
Material code	SCSC L EPSS 2A	SCSC O EPSS 2A	C-SC L EPSS 2A	ACSC O EPSS 2A	C-SC L EPSS 2A	C-SC O EPSS 2A

MOTOR	HP @ RPM (ODP & TEFC)		MAX. DIMENSIONS INCHES (mm)										ASSEMBLY WEIGHT*	
	1800	1200	A	B	C MAX		D1	D2	E	F	H	N	lbs (kgs)	
FRAME					ODP	TEFC							ODP	TEFC
182JM	—	1.5	9.00 (229)	5.75 (146)	15.00 (381)	17.00 (432)	8.25 (210)	4.50 (114)	3.75 (95)	4.50 (114)	0.41 (10)	7.38 (187)	192 (87.2)	194 (88.1)
184JM	5	—	9.00 (229)	6.75 (172)	16.00 (406)	18.00 (457)	8.25 (210)	4.50 (114)	3.75 (95)	5.50 (140)	0.41 (10)	7.38 (187)	196 (89.0)	201 (91.3)
213JP	7.5	2 & 3	10.50 (267)	7.00 (178)	21.00 (533)	23.00 (584)	8.25 (210)	5.25 (133)	4.25 (108)	5.50 (140)	0.41 (10)	12.13 (308)	226 (102.6)	236 (107.1)
215JP	10	5	10.50 (267)	8.50 (216)	23.00 (584)	25.00 (635)	8.25 (210)	5.25 (133)	4.25 (108)	7.00 (178)	0.41 (10)	12.13 (308)	241 (109.4)	258 (117.1)
254JM	15	—	12.38 (314)	10.50 (267)	22.00 (559)	24.00 (610)	8.25 (210)	6.25 (159)	5.00 (127)	8.25 (210)	0.53 (13)	9.75 (248)	286 (129.8)	336 (152.5)

PUMP DIMENSIONS

inches (mm)

X	Y
11.00 (279)	4.00 (102)

*Assembly weight combines pump and motor.

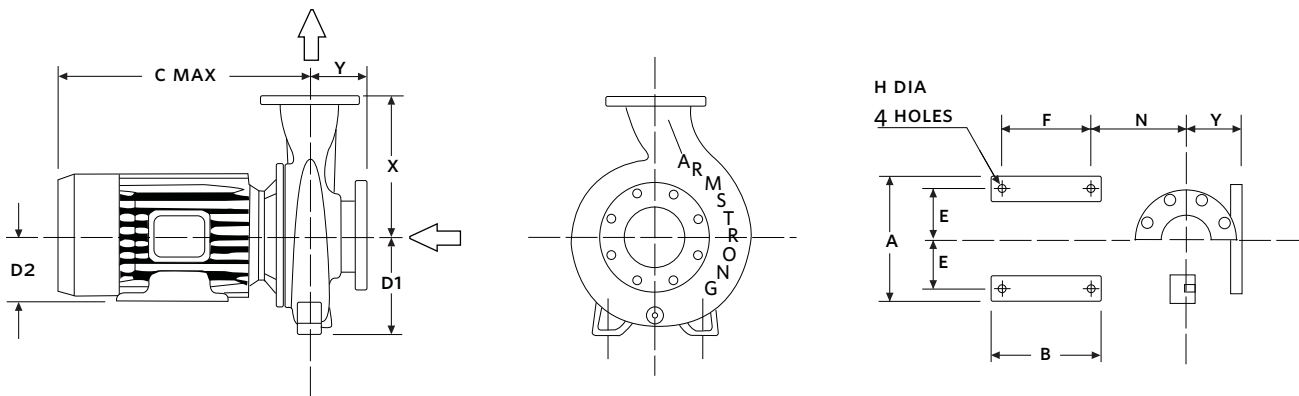

SERIES 4280 PERFORMANCE CURVES

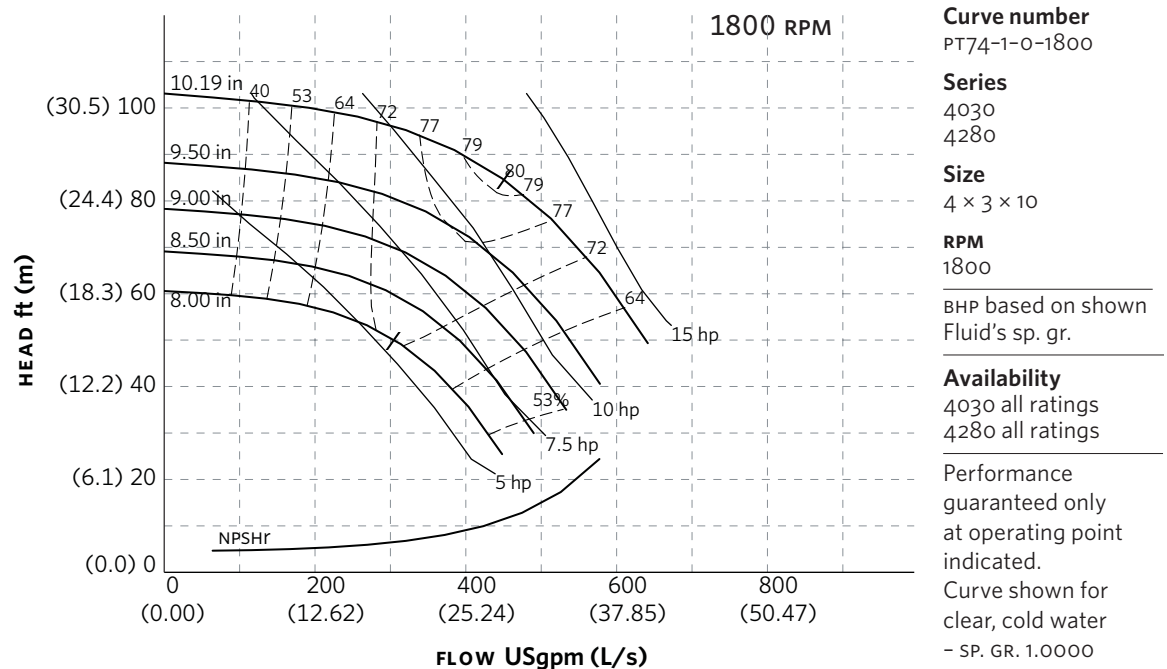
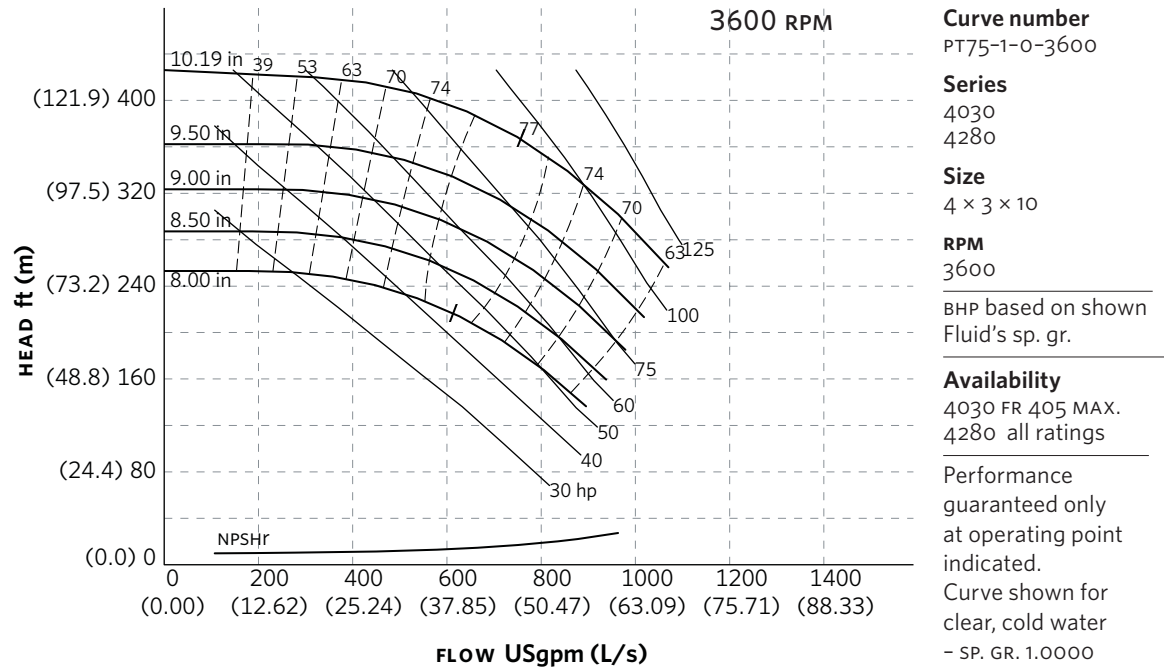

Performance curves are for reference only.
Confirm current performance data with Armstrong ACE ONLINE selection software.

TORONTO

23 BERTRAND AVENUE
TORONTO, ONTARIO
CANADA
M1L 2P3
+1 416 755 2291

BUFFALO

93 EAST AVENUE
NORTH TONAWANDA, NEW YORK
U.S.A.
14120-6594
+1 716 693 8813

BIRMINGHAM

HEYWOOD WHARF, MUCKLOW HILL
HALESOWEN, WEST MIDLANDS
UNITED KINGDOM
B62 8DJ
+44 (0) 8444 145 145

MANCHESTER

WENLOCK WAY
MANCHESTER
UNITED KINGDOM
M12 5JL
+44 (0) 8444 145 145

BANGALORE

#59, FIRST FLOOR, 3RD MAIN
MARGOSA ROAD, MALLESWARAM
BANGALORE, INDIA
560 003
+91 (0) 80 4906 3555

SHANGHAI

NO. 1619 HU HANG ROAD, XI DU TOWNSHIP
FENG XIAN DISTRICT, SHANGHAI
P.R.C.
201401
+86 21 3756 6696

ARMSTRONG INTEGRATED
ESTABLISHED 1934

ARMSTRONGINTEGRATED.COM

**MAKING
ENERGY
MAKE
SENSE™**