

JOB: UNIT TAG: ENGINEER: CONTRACTOR:	REPRESENTATIVE: ORDER NO.: SUBMITTED BY: APPROVED BY:	DATE: DATE: DATE:
-------------------------------------------------------------------------------	------------------------------------------------------------------------------------------------	----------------------------------------------

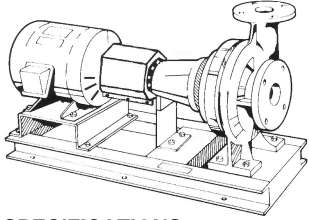

4GC Series e-1510

Centrifugal Pumps - Base Mounted

SPECIFICATIONS

FLOW _____ HEAD _____
 HP _____ RPM _____
 VOLTS _____
 CYCLE _____ PHASE _____
 ENCLOSURE _____
 APPROX. WEIGHT _____
 SPECIALS _____

Note: Equipped with NEOPRENE coupling

MATERIALS OF CONSTRUCTION

STAINLESS STEEL FITTED

FEATURES

- i-ALERT™ Condition Monitor
- ANSI/OSHA Coupling Guard
- Center Drop Out Spacer Coupling
- Fabricated Heavy Duty Baseplate

MAXIMUM WORKING PRESSURE

- 175 psi (12 bar) W.P. w/125# ANSI flange drilling
- 250 psi (17 bar) W.P. w/250# ANSI flange drilling (requires 1510-S)

TYPE OF SEAL

- Standard Seal (Buna-Carbon/Ceramic)
- F Standard Seal w/ Flush Line (Buna-Carbon/Ceramic)
- S Stuffing Box Construction w/ Flushed Mechanical Single Seal (EPR-Tungsten Carbide/Carbon)
- PF Stuffing Box Construction w/ Packing (Graphite Impregnated Teflon)

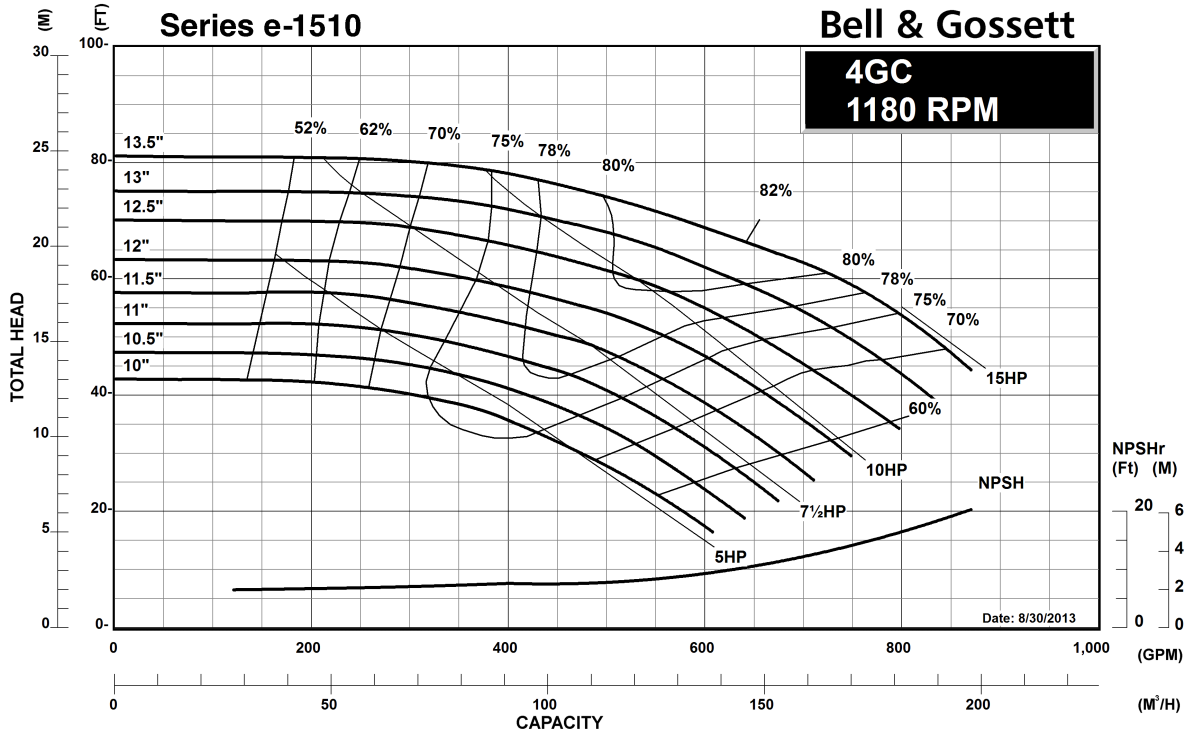

JOB: UNIT TAG: ENGINEER: CONTRACTOR:	REPRESENTATIVE: ORDER NO.: SUBMITTED BY: APPROVED BY:	DATE: DATE: DATE:
-------------------------------------------------------------------------------	------------------------------------------------------------------------------------------------	----------------------------------------------

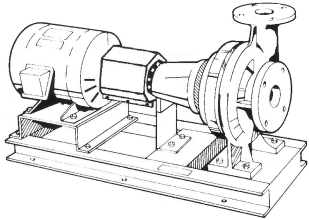

4GC

Series e-1510

Centrifugal Pumps - Base Mounted

SPECIFICATIONS

FLOW _____ HEAD _____

HP _____ RPM _____

VOLTS _____

CYCLE _____ PHASE _____

ENCLOSURE _____

APPROX. WEIGHT _____

SPECIALS _____

Note: Equipped with NEOPRENE coupling

MATERIALS OF CONSTRUCTION

STAINLESS STEEL FITTED

FEATURES

- i-ALERT™ Condition Monitor
- ANSI/OSHA Coupling Guard
- Center Drop Out Spacer Coupling
- Fabricated Heavy Duty Baseplate

MAXIMUM WORKING PRESSURE

- 175 psi (12 bar) W.P. w/125# ANSI flange drilling
- 250 psi (17 bar) W.P. w/250# ANSI flange drilling (requires 1510-S)

TYPE OF SEAL

- Standard Seal (Buna-Carbon/Ceramic)
- F Standard Seal w/ Flush Line (Buna-Carbon/Ceramic)
- S Stuffing Box Construction w/ Flushed Mechanical Single Seal (EPR-Tungsten Carbide/Carbon)
- PF Stuffing Box Construction w/ Packing (Graphite Impregnated Teflon)

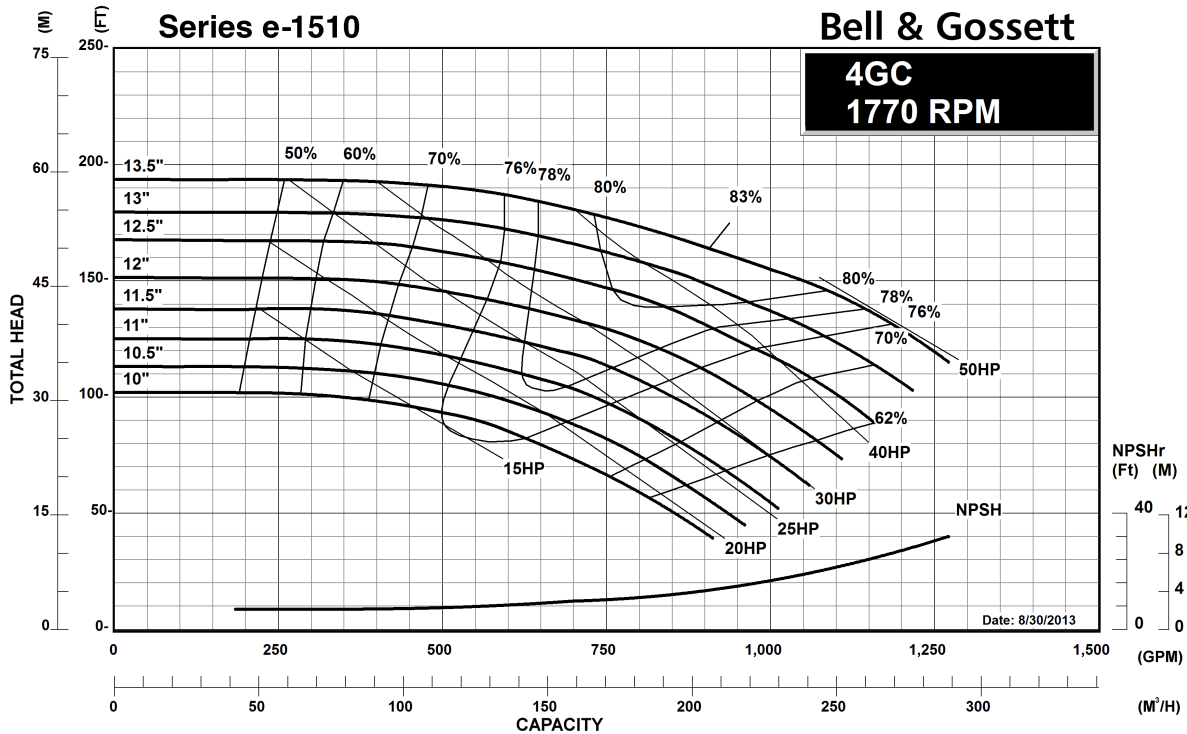

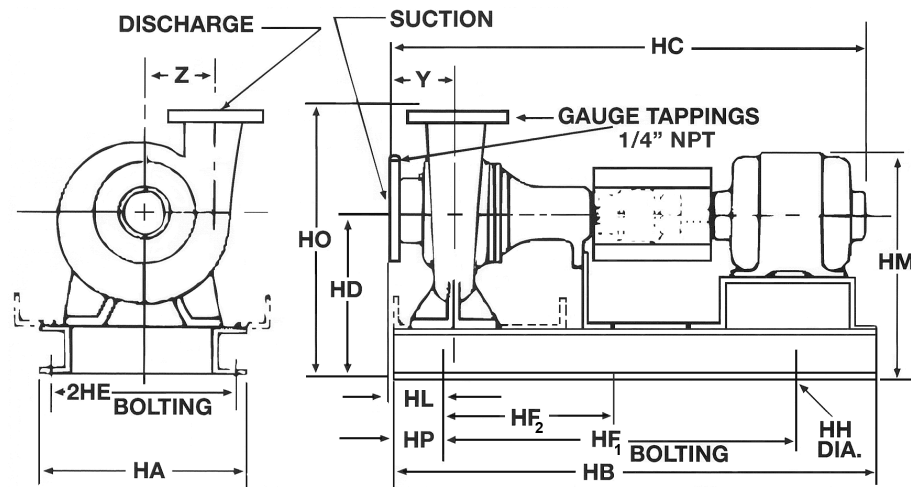

FLANGE DIMENSIONS IN INCHES (MM)			
	SIZE	THICKNESS	O.D.
Discharge	4" (102)	1-1/4 (32)	10 (254)
Suction	5" (127)	1-3/8 (35)	10-3/4 (273)

FLANGES ARE: 125# ANSI - STANDARD
250# ANSI - AVAILABLE

DIMENSIONS - Inches (mm)

STANDARD SEAL

MOTOR FRAME	HA	HB	HC MAX	HD	2HE	HF ₁	HF ₂	HH	HL	HM MAX	HO	HP	Y	Z
"L" FRAME														
213T	16 (406)	46-1/2 (1181)	41-5/8 (1057)	15 (381)	14 (356)	36-1/2 (927)	18-1/4 (464)	7/8 (22)	4-5/8 (117)	20-7/8 (530)	25 (635)	5 (127)	6 (152)	8-9/16 (217)
215T	16 (406)	46-1/2 (1181)	43-1/8 (1095)	15 (381)	14 (356)	36-1/2 (927)	18-1/4 (464)	7/8 (22)	4-5/8 (117)	20-7/8 (530)	25 (635)	5 (127)	6 (152)	8-9/16 (217)
254T	16 (406)	46-1/2 (1181)	46-7/8 (1191)	15 (381)	14 (356)	36-1/2 (927)	18-1/4 (464)	7/8 (22)	4-5/8 (117)	21-7/8 (556)	25 (635)	5 (127)	6 (152)	8-9/16 (217)
256T	16 (406)	46-1/2 (1181)	48-5/8 (1235)	15 (381)	14 (356)	36-1/2 (927)	18-1/4 (464)	7/8 (22)	4-5/8 (117)	21-7/8 (556)	25 (635)	5 (127)	6 (152)	8-9/16 (217)
284T	16 (406)	51-3/4 (1314)	49-3/8 (1254)	15 (381)	14 (356)	41-3/4 (1060)	20-7/8 (530)	7/8 (22)	4-5/8 (117)	23 (584)	25 (635)	5 (127)	6 (152)	8-9/16 (217)
286T	16 (406)	51-3/4 (1314)	50-7/8 (1292)	15 (381)	14 (356)	41-3/4 (1060)	20-7/8 (530)	7/8 (22)	4-5/8 (117)	23 (584)	25 (635)	5 (127)	6 (152)	8-9/16 (217)
324T	16 (406)	51-3/4 (1314)	53-1/8 (1349)	15 (381)	14 (356)	41-3/4 (1060)	20-7/8 (530)	7/8 (22)	4-5/8 (117)	24-1/8 (613)	25 (635)	5 (127)	6 (152)	8-9/16 (217)
326T	16 (406)	51-3/4 (1314)	54-5/8 (1387)	15 (381)	14 (356)	41-3/4 (1060)	20-7/8 (530)	7/8 (22)	4-5/8 (117)	24-1/8 (613)	25 (635)	5 (127)	6 (152)	8-9/16 (217)

STUFFING BOX

MOTOR FRAME	HA	HB	HC MAX	HD	2HE	HF ₁	HF ₂	HH	HL	HM MAX	HO	HP	Y	Z
"L" FRAME														
213T	16 (406)	46-1/2 (1181)	44 (1118)	15 (381)	14 (356)	36-1/2 (927)	18-1/4 (464)	7/8 (22)	4-5/8 (117)	20-7/8 (530)	25 (635)	5 (127)	6 (152)	8-9/16 (217)
215T	16 (406)	46-1/2 (1181)	45-1/2 (1156)	15 (381)	14 (356)	36-1/2 (927)	18-1/4 (464)	7/8 (22)	4-5/8 (117)	20-7/8 (530)	25 (635)	5 (127)	6 (152)	8-9/16 (217)
254T	16 (406)	51-3/4 (1314)	49-1/4 (1251)	15 (381)	14 (356)	41-3/4 (1060)	20-7/8 (530)	7/8 (22)	4-5/8 (117)	21-7/8 (556)	25 (635)	5 (127)	6 (152)	8-9/16 (217)
256T	16 (406)	51-3/4 (1314)	51 (1295)	15 (381)	14 (356)	41-3/4 (1060)	20-7/8 (530)	7/8 (22)	4-5/8 (117)	21-7/8 (556)	25 (635)	5 (127)	6 (152)	8-9/16 (217)
284T	16 (406)	51-3/4 (1314)	51-3/4 (1314)	15 (381)	14 (356)	41-3/4 (1060)	20-7/8 (530)	7/8 (22)	4-5/8 (117)	23 (584)	25 (635)	5 (127)	6 (152)	8-9/16 (217)
286T	16 (406)	51-3/4 (1314)	53-1/4 (1353)	15 (381)	14 (356)	41-3/4 (1060)	20-7/8 (530)	7/8 (22)	4-5/8 (117)	23 (584)	25 (635)	5 (127)	6 (152)	8-9/16 (217)
324T	16 (406)	51-3/4 (1314)	55-1/2 (1410)	15 (381)	14 (356)	41-3/4 (1060)	20-7/8 (530)	7/8 (22)	4-5/8 (117)	24-1/8 (613)	25 (635)	5 (127)	6 (152)	8-9/16 (217)
326T	16 (406)	51-3/4 (1314)	57 (1448)	15 (381)	14 (356)	41-3/4 (1060)	20-7/8 (530)	7/8 (22)	4-5/8 (117)	24-1/8 (613)	25 (635)	5 (127)	6 (152)	8-9/16 (217)

Dimensions are subject to change. Not to be used for construction purposes unless certified.

Xylem Inc.
8200 N. Austin Avenue
Morton Grove, IL 60053
Phone: (847)966-3700
Fax: (847)965-8379
www.bellgossett.com

