

## SERIES 4280 | END SUCTION MOTOR MOUNTED CLOSED-COUPLED | 3 × 2.5 × 10 | SUBMITTAL

File No: 42.69  
Date: SEPTEMBER 10, 2012  
Supersedes: 42.69  
Date: DECEMBER 15, 2010

Job: \_\_\_\_\_ Representative: \_\_\_\_\_  
 \_\_\_\_\_ Order no: \_\_\_\_\_ Date: \_\_\_\_\_  
 Engineer: \_\_\_\_\_ Submitted by: \_\_\_\_\_ Date: \_\_\_\_\_  
 Contractor: \_\_\_\_\_ Approved by: \_\_\_\_\_ Date: \_\_\_\_\_

### PUMP DESIGN DATA

No. of pumps: \_\_\_\_\_ Tag: \_\_\_\_\_  
 Capacity: \_\_\_\_\_ USgpm (L/s) Head: \_\_\_\_\_ ft (m)  
 Liquid: \_\_\_\_\_ Viscosity: \_\_\_\_\_  
 Temperature: \_\_\_\_\_ °F (°C) Specific gravity: \_\_\_\_\_  
 Suction: 3" (75mm) Flanged  
 Discharge: 2.5" (62mm) Flanged

### MOTOR DESIGN DATA

HP: \_\_\_\_\_ RPM: \_\_\_\_\_ Frame size: \_\_\_\_\_ Enclosure: \_\_\_\_\_  
 Volts: \_\_\_\_\_ Hertz: 60 Hz Phase: 3  
 Efficiency:  Energy EFF 12.11  NEMA premium 12.12

### MATERIALS OF CONSTRUCTION

ANSI FLANGE RATING	ANSI 125	ANSI 250
<b>Construction</b>	<input type="checkbox"/> BF	<input type="checkbox"/> DBF
<b>Casing</b>	Cast iron	Ductile iron
<b>Adapter</b>	Cast iron	Ductile iron

**Impeller:** Bronze

**Gasket:** Confined non-asbestos fiber

**Shaft:** Carbon steel

**Shaft sleeve:** Bronze

### MAXIMUM PUMP OPERATING CONDITIONS

#### ANSI 125

175 psig at 150°F (12 bars at 65°C)  
 140 psig at 250°F (10 bars at 121°C)

#### ANSI 250

300 psig at 150°F (20 bars at 65°C)  
 250 psig at 250°F (17 bars at 121°C)

- Tolerance of ±0.125" (±3 mm) should be used
- See performance curves on page 3
- For exact installation, data please write factory for certified dimensions
- Pump equipped with casing drain plug and ¼" NPT suction and discharge gauge ports

### MECHANICAL SEAL DATA

**Seal type:** 2A **Stationary seat:** Silicone carbide  
**Secondary seal:** EPDM **Rotating hardware:** Stainless steel  
**Spring:** Stainless steel

### OPTIONAL EQUIPMENT

FLUID TYPE	ALL GLYCOLS > 30% WT CONC		ALL OTHER NON-POTABLE FLUIDS		POTABLE (DRINKING) WATER	
	up to 200°F (93°C)	over 200°F (93°C)	up to 200°F (93°C)	over 200°F (93°C)	up to 200°F (93°C)	over 200°F (93°C)
<b>Temperature</b>	up to 200°F (93°C)	over 200°F (93°C)	up to 200°F (93°C)	over 200°F (93°C)	up to 200°F (93°C)	over 200°F (93°C)
<b>Rotating face</b>	Silicone carbide		Resin bonded carbon	Antimony loaded carbon	Resin bonded carbon	
<b>Seat elastomer</b>	EPDM (L-cup)	EPDM (O-ring)	EPDM (L-cup)	EPDM (O-ring)	EPDM (L-cup)	EPDM (O-ring)
<b>Material code</b>	SCSC L EPSS 2A	SCSC O EPSS 2A	C-SC L EPSS 2A	ACSC O EPSS 2A	C-SC L EPSS 2A	C-SC O EPSS 2A

MOTOR	HP @ RPM (ODP & TEFC)			MAX. DIMENSIONS INCHES (mm)										ASSEMBLY WEIGHT*	
	3600	1800	1200	A	B	C MAX		D1	D2	E	F	H	N	lbs (kgs)	
FRAME						ODP	TEFC							ODP	TEFC
145JM	—	—	1	7.00 (178)	6.00 (152)	14.00 (356)	16.00 (406)	8.25 (210)	3.50 (89)	2.75 (70)	5.00 (127)	0.35 (9)	6.63 (168)	157 (71.3)	162 (73.5)
182JM	—	3	—	9.00 (229)	5.75 (146)	15.00 (381)	17.00 (432)	8.25 (210)	4.50 (114)	3.75 (95)	4.50 (114)	0.41 (10)	7.38 (187)	172 (78.1)	187 (84.9)
184JM	—	5	—	9.00 (229)	6.75 (172)	16.00 (406)	18.00 (457)	8.25 (210)	4.50 (114)	3.75 (95)	5.50 (140)	0.41 (10)	7.38 (187)	192 (87.2)	197 (89.4)
213JP	—	7.5	2 & 3	10.50 (267)	7.00 (178)	21.00 (533)	23.00 (584)	8.25 (210)	5.25 (133)	4.25 (108)	5.50 (140)	0.41 (10)	12.13 (308)	222 (100.8)	232 (105.3)
215JP	—	10	5	10.50 (267)	8.50 (216)	23.00 (584)	25.00 (635)	8.25 (210)	5.25 (133)	4.25 (108)	7.00 (178)	0.41 (10)	12.13 (308)	237 (107.6)	247 (112.1)
254JM	—	15	—	12.38 (314)	10.50 (267)	22.00 (559)	24.00 (610)	8.25 (210)	6.25 (159)	5.00 (127)	8.25 (210)	0.53 (13)	9.75 (248)	282 (128.0)	332 (150.7)
284JM	30	—	—	13.88 (353)	12.25 (311)	27.00 (686)	29.00 (737)	8.25 (210)	7.00 (178)	5.50 (140)	9.50 (241)	0.53 (13)	12.63 (321)	352 (159.8)	422 (191.6)
286JM	40	—	—	13.88 (353)	13.75 (349)	29.00 (737)	31.00 (787)	8.25 (210)	8.00 (203)	5.50 (140)	11.00 (279)	0.53 (13)	12.63 (321)	442 (200.7)	532 (241.5)
324JM	50	—	—	15.88 (403)	13.75 (349)	29.00 (737)	31.00 (787)	8.25 (210)	8.00 (203)	6.25 (159)	10.50 (267)	0.66 (17)	13.13 (334)	542 (246.1)	652 (296.0)
326JM	60	—	—	15.88 (403)	15.25 (387)	31.00 (787)	33.00 (838)	8.25 (210)	8.00 (203)	6.25 (159)	12.00 (305)	0.66 (17)	13.13 (334)	582 (264.2)	712 (323.2)

**PUMP DIMENSIONS**

inches (mm)

X	Y
9.50 (241)	4.00 (102)

\*Assembly weight combines pump and motor.

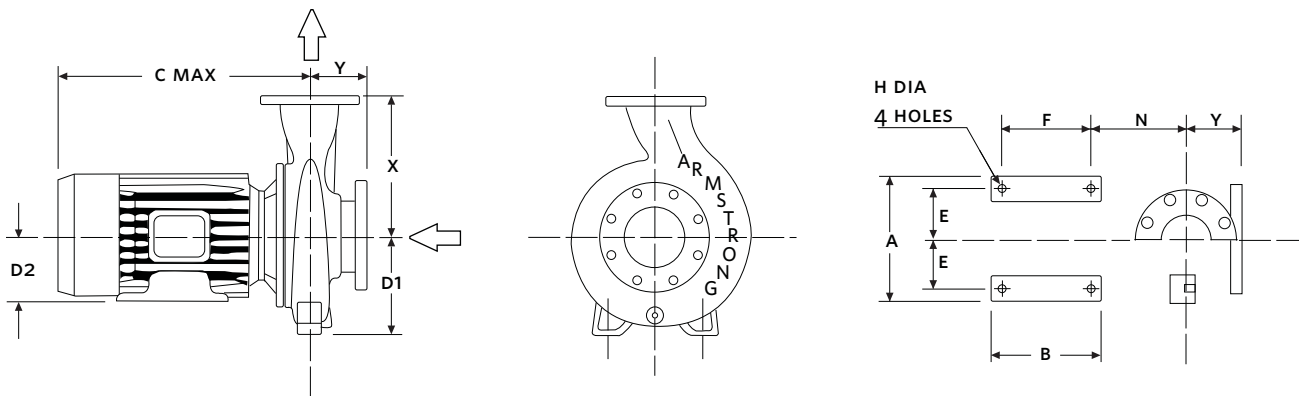

**SERIES 4280 PERFORMANCE CURVES**

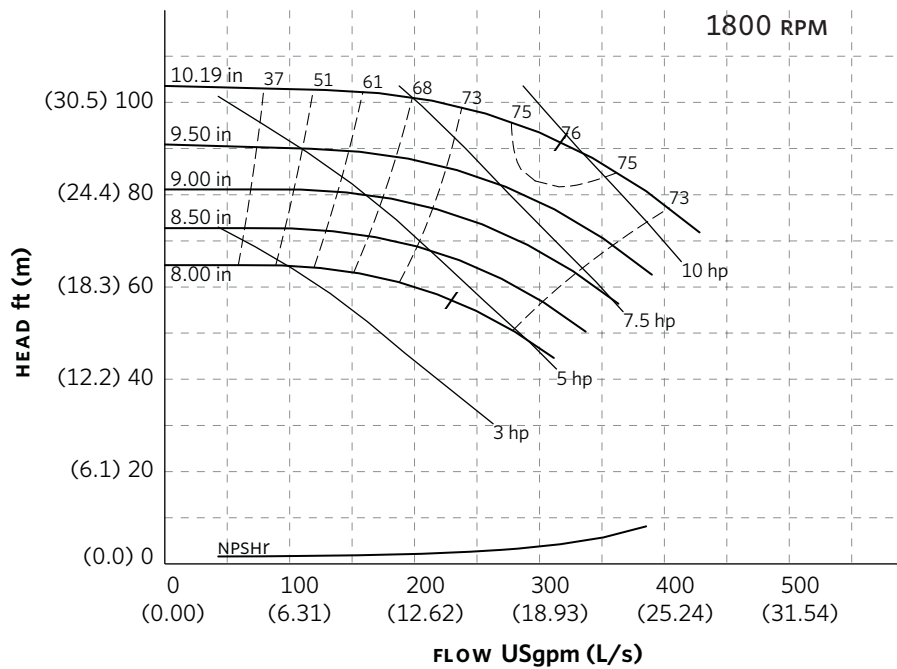
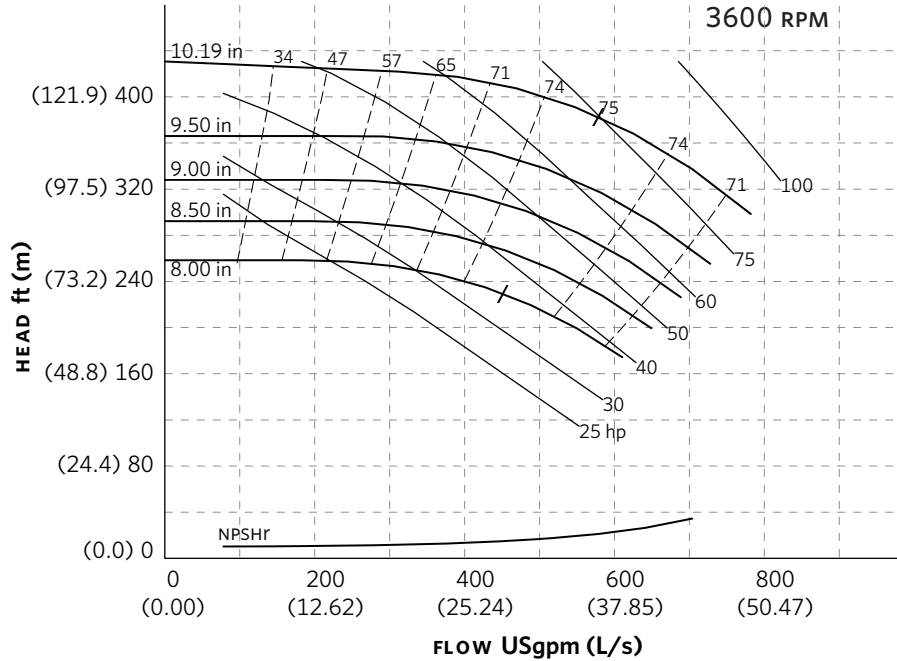

Performance curves are for reference only.  
 Confirm current performance data with Armstrong ACE ONLINE selection software.

**TORONTO**

23 BERTRAND AVENUE  
TORONTO, ONTARIO  
CANADA  
M1L 2P3  
+1 416 755 2291

**BUFFALO**

93 EAST AVENUE  
NORTH TONAWANDA, NEW YORK  
U.S.A.  
14120-6594  
+1 716 693 8813

**BIRMINGHAM**

HEYWOOD WHARF, MUCKLOW HILL  
HALESOWEN, WEST MIDLANDS  
UNITED KINGDOM  
B62 8DJ  
+44 (0) 8444 145 145

**MANCHESTER**

WENLOCK WAY  
MANCHESTER  
UNITED KINGDOM  
M12 5JL  
+44 (0) 8444 145 145

**BANGALORE**

#59, FIRST FLOOR, 3RD MAIN  
MARGOSA ROAD, MALLESWARAM  
BANGALORE, INDIA  
560 003  
+91 (0) 80 4906 3555

**SHANGHAI**

NO. 1619 HU HANG ROAD, XI DU TOWNSHIP  
FENG XIAN DISTRICT, SHANGHAI  
P.R.C.  
201401  
+86 21 3756 6696

ARMSTRONG INTEGRATED  
ESTABLISHED 1934

ARMSTRONGINTEGRATED.COM

**MAKING  
ENERGY  
MAKE  
SENSE™**