

SERIES 4030 | END SUCTION BASE MOUNTED SPLIT COUPLED | 3 × 1.5 × 8 | SUBMITTAL

File No: 40.56
Date: OCTOBER 15, 2013
Supersedes: 40.56
Date: JULY 10, 2013

Job: _____ Representative: _____

Order no.: _____ Date: _____

Engineer: _____ Submitted by: _____ Date: _____

Contractor: _____ Approved by: _____ Date: _____

PUMP DESIGN DATA

No. of pumps: _____ Tag: _____
Capacity: _____ USgpm (L/s) Head: _____ ft (m)
Liquid: _____ Viscosity: _____
Temperature: _____ °F (°C) Specific gravity: _____
Suction: 3" (75mm) Flanged
Discharge: 1.5" (38mm) Flanged

MATERIALS OF CONSTRUCTION

ANSI FLANGE RATING	ANSI 125	ANSI 250
Construction	<input type="checkbox"/> BF	<input type="checkbox"/> DBF
Casing	Cast iron	Ductile iron

Impeller: Bronze
Gasket: Confined non-asbestos fiber
Bearing frame: Cast iron
Anti-friction bearings: Permanently lubricated
Shaft: Carbon steel
Shaft sleeve: Stainless steel
Coupler: Constant speed: Woods sure-flex or equal
Variable speed: Woods dura-flex or equal
Coupler guard: Steel OSHA
Baseplate: Fabricated steel

MECHANICAL SEAL DATA

Seal type: 2A **Stationary seat:** Silicone carbide
Secondary seal: EPDM **Rotating hardware:** Stainless steel
Spring: Stainless steel

FLUID TYPE	ALL GLYCOLS > 30% WT CONC		ALL OTHER NON-POTABLE FLUIDS		POTABLE (DRINKING) WATER	
	up to 200°F (93°C)	over 200°F (93°C)	up to 200°F (93°C)	over 200°F (93°C)	up to 200°F (93°C)	over 200°F (93°C)
Temperature	up to 200°F (93°C)	over 200°F (93°C)	up to 200°F (93°C)	over 200°F (93°C)	up to 200°F (93°C)	over 200°F (93°C)
Rotating face	Silicone carbide		Resin bonded carbon	Antimony loaded carbon	Resin bonded carbon	
Seat elastomer	EPDM (L-cup)	EPDM (O-ring)	EPDM (L-cup)	EPDM (O-ring)	EPDM (L-cup)	EPDM (O-ring)
Material code	SCSc L EPSS 2A	SCSc O EPSS 2A	C-Sc L EPSS 2A	ACSc O EPSS 2A	C-Sc L EPSS 2A	C-Sc O EPSS 2A

MOTOR DESIGN DATA

HP: _____ RPM: _____ Frame size: _____ Enclosure: _____
Volts: _____ Hertz: 60 Hz Phase: 3
Efficiency*: NEMA premium 12.12 Other _____ %

* Fractional power and frame 56 motors are supplied with the standard efficiency of the manufacturer.

MAXIMUM PUMP OPERATING CONDITIONS

ANSI 125

175 psig at 150°F (12 bars at 65°C)
140 psig at 250°F (10 bars at 121°C)

ANSI 250

300 psig at 150°F (20 bars at 65°C)
250 psig at 250°F (17 bars at 121°C)

- Tolerance of ±0.125" (±3 mm) should be used
- See performance curves on page 3
- For exact installation, data please write factory for certified dimensions
- Pump equipped with casing drain plug and ¼" NPT suction and discharge gauge ports

OPTIONAL EQUIPMENT

MOTOR	HORSEPOWER @ RPM				MAX. DIMENSIONS INCHES (mm)											MAX. ASSEMBLY WEIGHT*	
	3600		1800	1200	HA	HB	HC	HD	HE	HF	HG	HH	HL	X	Y	lbs (kgs)	
FRAME	ODP	TEFC														ODP	TEFC
56C	—	—	—	0.33 & 0.5	14.00 (356)	30.00 (762)	26.38 (670)	9.25 (235)	6.38 (162)	26.00 (660)	3.00 (76)	0.75 (19)	4.50 (114)	8.50 (216)	4.00 (102)	132 (59.9)	132 (59.9)
143TC	—	—	1	0.75	14.00 (356)	30.00 (762)	28.03 (712)	9.25 (235)	6.38 (162)	26.00 (660)	3.00 (76)	0.75 (19)	4.50 (114)	8.50 (216)	4.00 (102)	137 (62.1)	142 (64.4)
145TC	—	—	1.5 & 2	1	14.00 (356)	30.00 (762)	28.03 (712)	9.25 (235)	6.38 (162)	26.00 (660)	3.00 (76)	0.75 (19)	4.50 (114)	8.50 (216)	4.00 (102)	142 (64.4)	142 (64.4)
182TC	—	—	3	—	14.00 (356)	30.00 (762)	30.72 (780)	9.25 (235)	6.38 (162)	26.00 (660)	3.00 (76)	0.75 (19)	4.50 (114)	8.50 (216)	4.00 (102)	157 (71.2)	167 (75.7)
184TC	7.5	—	5	—	14.00 (356)	30.00 (762)	30.72 (780)	9.25 (235)	6.38 (162)	26.00 (660)	3.00 (76)	0.75 (19)	4.50 (114)	8.50 (216)	4.00 (102)	167 (75.7)	177 (80.3)
213TC	10	7.5	—	—	14.00 (356)	33.00 (838)	34.40 (874)	9.25 (235)	6.38 (162)	29.00 (737)	3.00 (76)	0.75 (19)	4.50 (114)	8.50 (216)	4.00 (102)	167 (75.7)	212 (96.2)
215TC	15	10	—	—	14.00 (356)	33.00 (838)	34.40 (874)	9.25 (235)	6.38 (162)	29.00 (737)	3.00 (76)	0.75 (19)	4.50 (114)	8.50 (216)	4.00 (102)	197 (89.4)	227 (103.0)
254TC	20	15	—	—	16.00 (406)	40.00 (1016)	40.38 (1026)	9.25 (235)	7.38 (187)	36.00 (914)	3.00 (76)	0.75 (19)	4.50 (114)	8.50 (216)	4.00 (102)	207 (93.9)	297 (134.7)
256TC	25	20	—	—	16.00 (406)	40.00 (1016)	40.38 (1026)	9.25 (235)	7.38 (187)	36.00 (914)	3.00 (76)	0.75 (19)	4.50 (114)	8.50 (216)	4.00 (102)	257 (116.6)	317 (143.8)
284TSC	30	25	—	—	19.00 (483)	48.00 (1219)	44.63 (1134)	12.25 (311)	8.88 (225)	44.00 (1118)	4.00 (102)	0.75 (19)	4.50 (114)	8.50 (216)	4.00 (102)	317 (143.8)	387 (175.5)
286TSC	—	30	—	—	19.00 (483)	48.00 (1219)	44.63 (1134)	12.25 (311)	8.88 (225)	44.00 (1118)	4.00 (102)	0.75 (19)	4.50 (114)	8.50 (216)	4.00 (102)	387 (175.5)	457 (207.3)

*Assembly weight combines pump and motor.

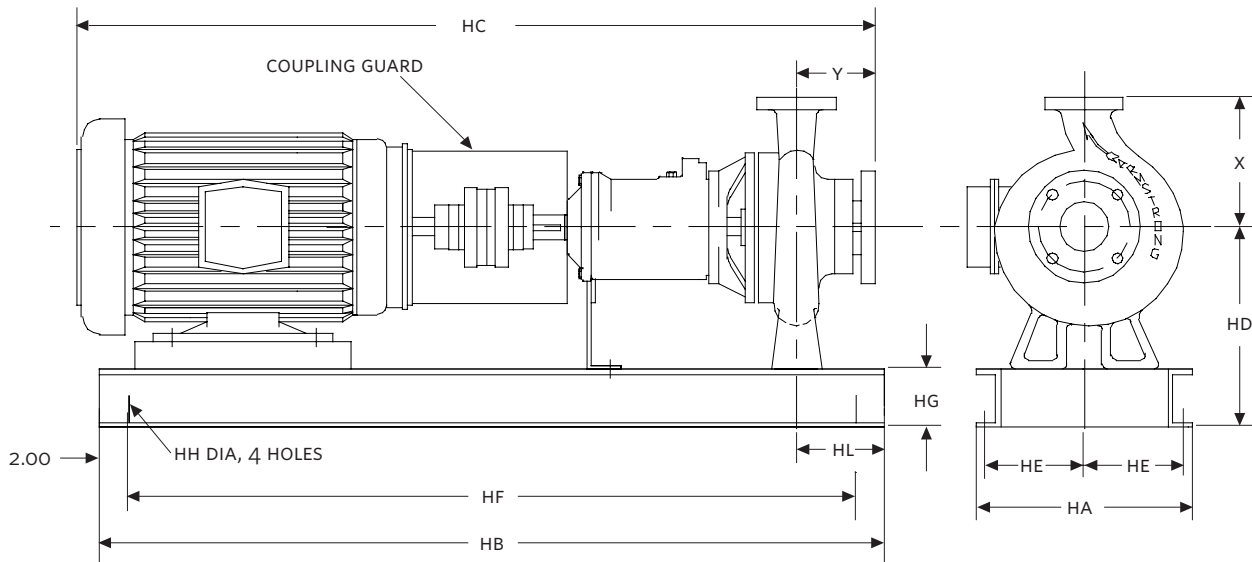

SERIES 4030 PERFORMANCE CURVES

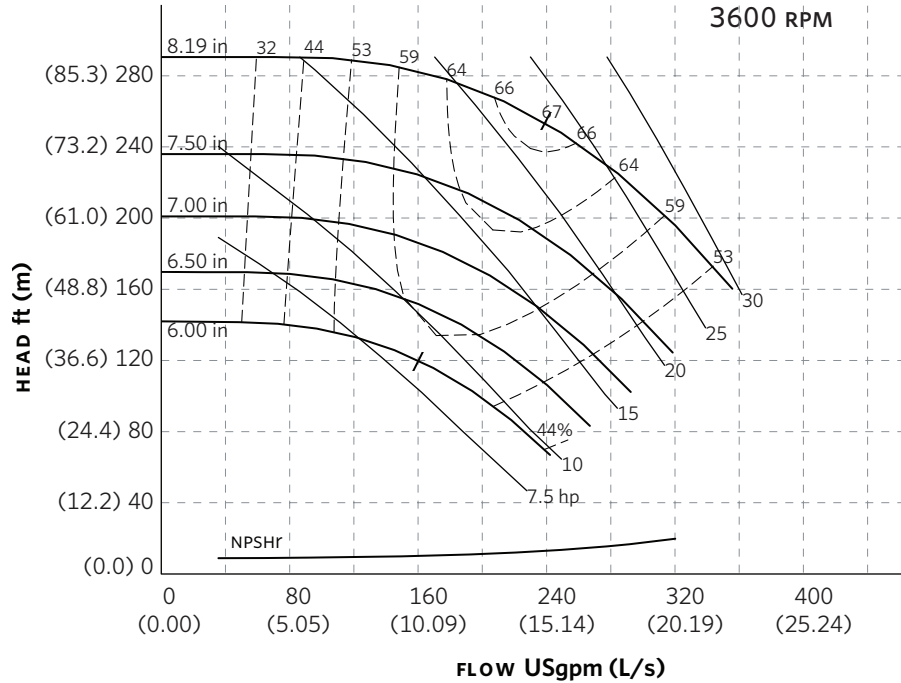

Curve number
PT51-2-0-3600

Series
4030
4280

Size
3 × 1.5 × 8

RPM
3600

BHP based on shown
Fluid's sp. gr.

Availability
4030 all ratings
4280 all ratings

Performance
guaranteed only
at operating point
indicated.

Curve shown for
clear, cold water
- SP. GR. 1.0000

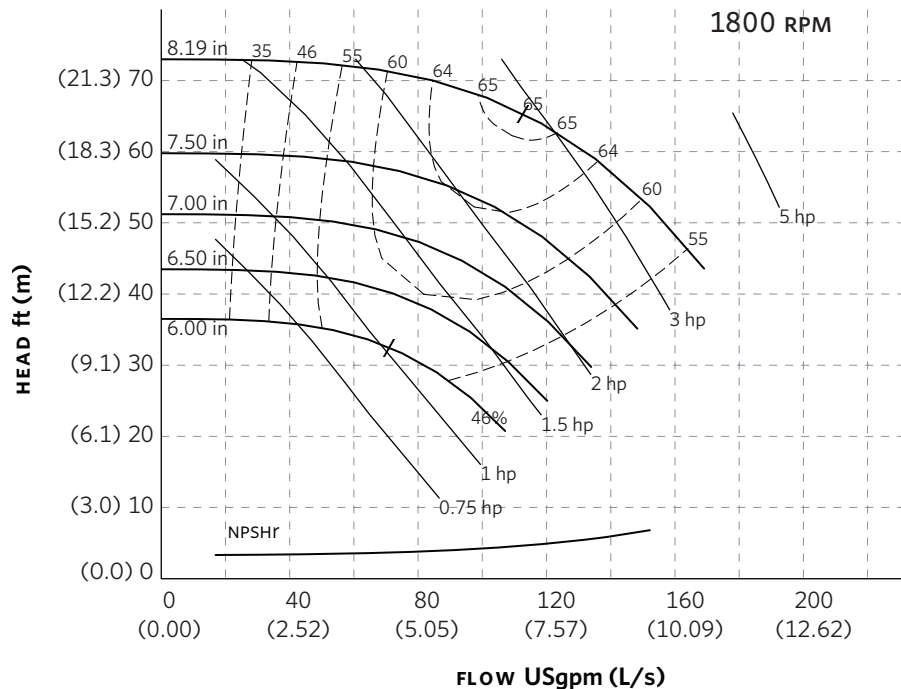

Curve number
PT50-2-0-1800

Series
4030
4280

Size
3 × 1.5 × 8

RPM
1800

BHP based on shown
Fluid's sp. gr.

Availability
4030 all ratings
4280 all ratings

Performance
guaranteed only
at operating point
indicated.

Curve shown for
clear, cold water
- SP. GR. 1.0000

Performance curves are for reference only.
Confirm current performance data with Armstrong ACE Online selection software.

TORONTO

23 BERTRAND AVENUE
TORONTO, ONTARIO
CANADA
M1L 2P3
+1 416 755 2291

BUFFALO

93 EAST AVENUE
NORTH TONAWANDA, NEW YORK
U.S.A.
14120-6594
+1 716 693 8813

BIRMINGHAM

HEYWOOD WHARF, MUCKLOW HILL
HALESOWEN, WEST MIDLANDS
UNITED KINGDOM
B62 8DJ
+44 (0) 8444 145 145

MANCHESTER

WENLOCK WAY
MANCHESTER
UNITED KINGDOM
M12 5JL
+44 (0) 8444 145 145

BANGALORE

#59, FIRST FLOOR, 3RD MAIN
MARGOSA ROAD, MALLESWARAM
BANGALORE, INDIA
560 003
+91 (0) 80 4906 3555

SHANGHAI

NO. 1619 HU HANG ROAD, XI DU TOWNSHIP
FENG XIAN DISTRICT, SHANGHAI
P.R.C.
201401
+86 21 3756 6696

**MAKING
ENERGY
MAKE
SENSE™**