

SERIES 4280 | END SUCTION MOTOR MOUNTED CLOSED-COUPLED | 3 × 1.5 × 8 | SUBMITTAL

File No: 42.60
Date: SEPTEMBER 10, 2012
Supersedes: 42.60
Date: DECEMBER 15, 2010

Job: _____ Representative: _____
 _____ Order no: _____ Date: _____
 Engineer: _____ Submitted by: _____ Date: _____
 Contractor: _____ Approved by: _____ Date: _____

PUMP DESIGN DATA

No. of pumps: _____ Tag: _____
 Capacity: _____ USgpm (L/s) Head: _____ ft (m)
 Liquid: _____ Viscosity: _____
 Temperature: _____ °F (°C) Specific gravity: _____
 Suction: 3" (75mm) Flanged
 Discharge: 1.5" (38mm) Flanged

MOTOR DESIGN DATA

HP: _____ RPM: _____ Frame size: _____ Enclosure: _____
 Volts: _____ Hertz: 60 Hz Phase: 3
 Efficiency: Energy EFF 12.11 NEMA premium 12.12

MATERIALS OF CONSTRUCTION

ANSI FLANGE RATING	ANSI 125	ANSI 250
Construction	<input type="checkbox"/> BF	<input type="checkbox"/> DBF
Casing	Cast iron	Ductile iron
Adapter	Cast iron	Ductile iron

Impeller: Bronze

Gasket: Confined non-asbestos fiber

Shaft: Carbon steel

Shaft sleeve: Bronze

MAXIMUM PUMP OPERATING CONDITIONS

ANSI 125

175 psig at 150°F (12 bars at 65°C)
 140 psig at 250°F (10 bars at 121°C)

ANSI 250

300 psig at 150°F (20 bars at 65°C)
 250 psig at 250°F (17 bars at 121°C)

- Tolerance of ±0.125" (±3 mm) should be used
- See performance curves on page 3
- For exact installation, data please write factory for certified dimensions
- Pump equipped with casing drain plug and ¼" NPT suction and discharge gauge ports

MECHANICAL SEAL DATA

Seal type: 2A **Stationary seat:** Silicone carbide
Secondary seal: EPDM **Rotating hardware:** Stainless steel
Spring: Stainless steel

OPTIONAL EQUIPMENT

FLUID TYPE	ALL GLYCOLS > 30% WT CONC		ALL OTHER NON-POTABLE FLUIDS		POTABLE (DRINKING) WATER	
	up to 200°F (93°C)	over 200°F (93°C)	up to 200°F (93°C)	over 200°F (93°C)	up to 200°F (93°C)	over 200°F (93°C)
Temperature	up to 200°F (93°C)	over 200°F (93°C)	up to 200°F (93°C)	over 200°F (93°C)	up to 200°F (93°C)	over 200°F (93°C)
Rotating face	Silicone carbide		Resin bonded carbon	Antimony loaded carbon	Resin bonded carbon	
Seat elastomer	EPDM (L-cup)	EPDM (O-ring)	EPDM (L-cup)	EPDM (O-ring)	EPDM (L-cup)	EPDM (O-ring)
Material code	SCSC L EPSS 2A	SCSC O EPSS 2A	C-SC L EPSS 2A	ACSC O EPSS 2A	C-SC L EPSS 2A	C-SC O EPSS 2A

MOTOR	HP @ RPM (ODP & TEFC)			MAX. DIMENSIONS INCHES (mm)										ASSEMBLY WEIGHT*	
	3600	1800	1200	A	B	C MAX		D1	D2	E	F	H	N	lbs (kgs)	
FRAME						ODP	TEFC							ODP	TEFC
143JM	—	1	—	7.00 (178)	5.00 (127)	13.00 (330)	15.00 (381)	5.63 (143)	3.50 (89)	2.75 (70)	4.00 (102)	0.35 (9)	6.63 (168)	106 (48.1)	116 (52.7)
145JM	—	1.5 & 2	1	7.00 (178)	6.00 (152)	14.00 (356)	16.00 (406)	5.63 (143)	3.50 (89)	2.75 (70)	5.00 (127)	0.35 (9)	6.63 (168)	111 (50.4)	116 (52.7)
182JM	—	3	—	9.00 (229)	5.75 (146)	15.00 (381)	17.00 (432)	5.63 (143)	4.50 (114)	3.75 (95)	4.50 (114)	0.41 (10)	7.38 (187)	126 (57.2)	141 (64.0)
184JM	7.5	5	—	9.00 (229)	6.75 (172)	16.00 (406)	18.00 (457)	5.63 (143)	4.50 (114)	3.75 (95)	5.50 (140)	0.41 (10)	7.38 (187)	151 (68.6)	176 (79.9)
213JP	10	—	—	10.50 (267)	7.00 (178)	21.00 (533)	23.00 (584)	5.63 (143)	5.25 (133)	4.25 (108)	5.50 (140)	0.41 (10)	12.13 (308)	186 (84.4)	201 (91.3)
215JP	15	—	—	10.50 (267)	8.50 (216)	23.00 (584)	25.00 (635)	5.63 (143)	5.25 (133)	4.25 (108)	7.00 (178)	0.41 (10)	12.13 (308)	216 (98.1)	226 (102.6)
254JM	20	—	—	12.38 (314)	10.50 (267)	22.00 (559)	24.00 (610)	5.63 (143)	6.25 (159)	5.00 (127)	8.25 (210)	0.53 (13)	9.75 (248)	236 (107.1)	301 (136.7)
256JM	25	—	—	12.38 (314)	12.25 (311)	24.00 (610)	26.00 (660)	5.63 (143)	6.25 (159)	5.00 (127)	10.00 (254)	0.53 (13)	9.75 (248)	271 (123.0)	336 (152.5)
284JM	30	—	—	13.88 (353)	12.25 (311)	24.00 (610)	26.00 (660)	5.63 (143)	7.00 (178)	5.50 (140)	9.50 (241)	0.53 (13)	9.75 (248)	306 (138.9)	376 (170.7)

PUMP DIMENSIONS
inches (mm)

X	Y
8.50 (216)	4.00 (102)

*Assembly weight combines pump and motor.

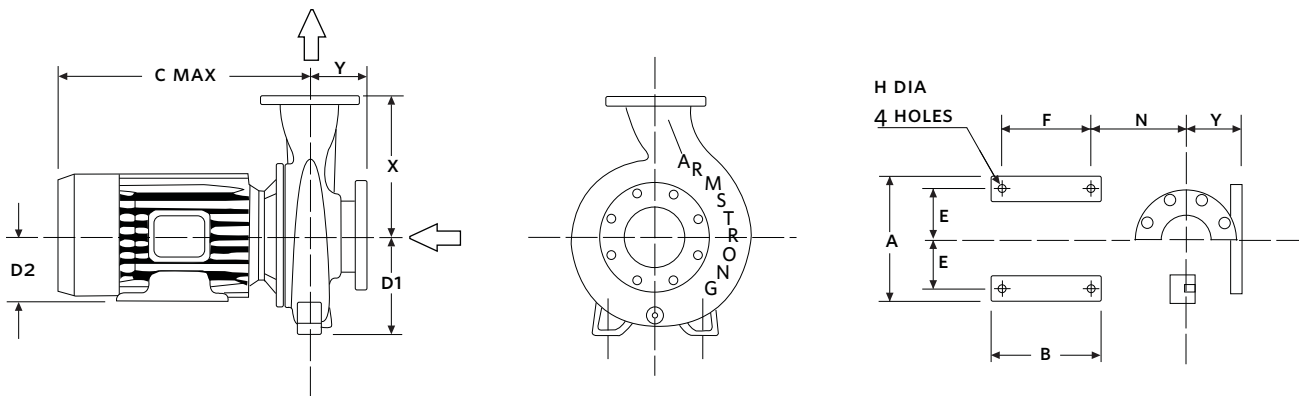

SERIES 4280 PERFORMANCE CURVES

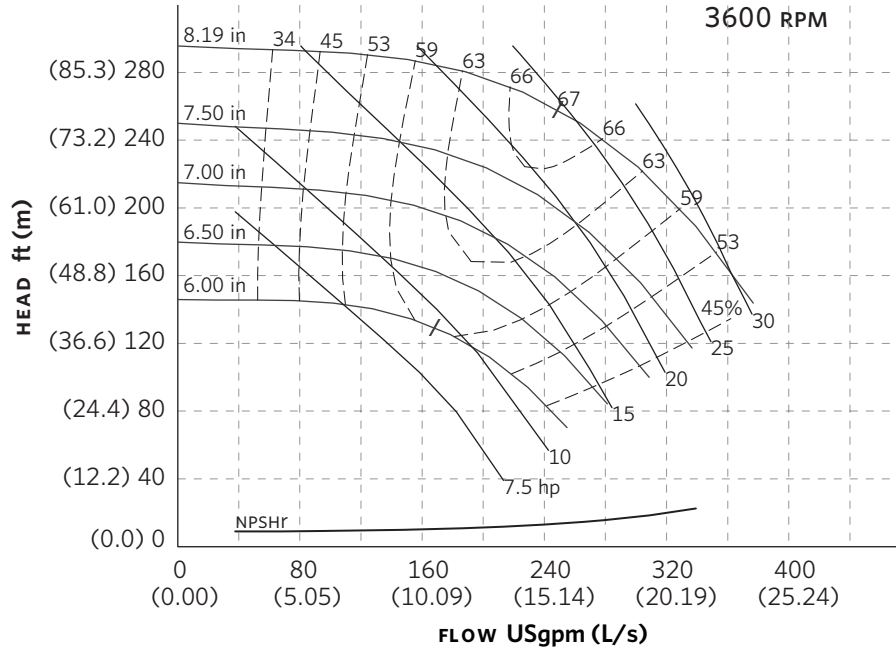

Curve number
PT51-3-0-3600

Series
4030
4280

Size
3 × 1.5 × 8

RPM
3600

BHP based on shown
Fluid's sp. gr.

Availability
4030 all ratings
4280 all ratings

Performance
guaranteed only
at operating point
indicated.

Curve shown for
clear, cold water
- SP. GR. 1.0000

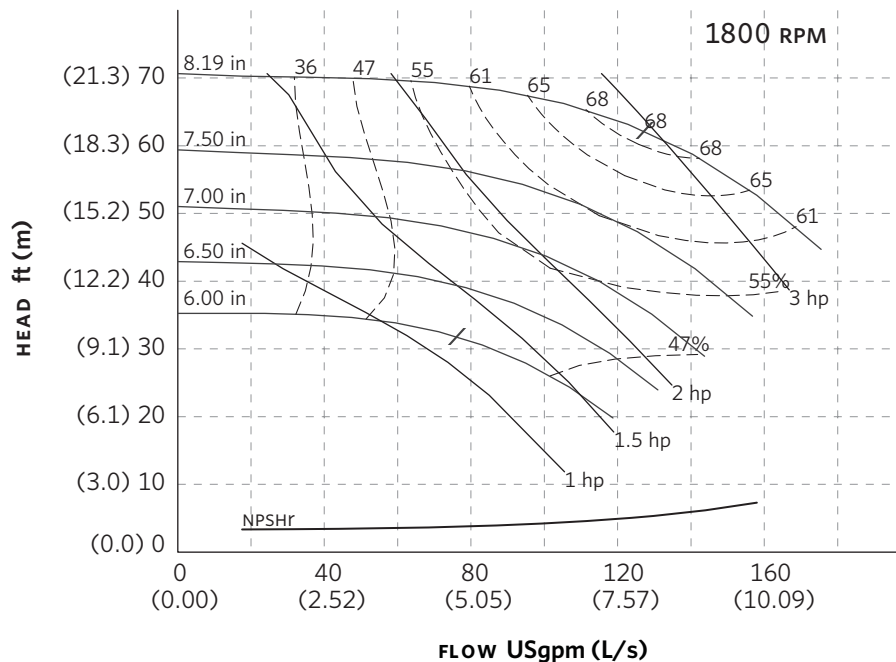

Curve number
PT50-4-0-1800

Series
4030
4280

Size
3 × 1.5 × 8

RPM
1800

BHP based on shown
Fluid's sp. gr.

Availability
4030 all ratings
4280 all ratings

Performance
guaranteed only
at operating point
indicated.

Curve shown for
clear, cold water
- SP. GR. 1.0000

Performance curves are for reference only.
Confirm current performance data with Armstrong ACE ONLINE selection software.

TORONTO

23 BERTRAND AVENUE
TORONTO, ONTARIO
CANADA
M1L 2P3
+1 416 755 2291

BUFFALO

93 EAST AVENUE
NORTH TONAWANDA, NEW YORK
U.S.A.
14120-6594
+1 716 693 8813

BIRMINGHAM

HEYWOOD WHARF, MUCKLOW HILL
HALESOWEN, WEST MIDLANDS
UNITED KINGDOM
B62 8DJ
+44 (0) 8444 145 145

MANCHESTER

WENLOCK WAY
MANCHESTER
UNITED KINGDOM
M12 5JL
+44 (0) 8444 145 145

BANGALORE

#59, FIRST FLOOR, 3RD MAIN
MARGOSA ROAD, MALLESWARAM
BANGALORE, INDIA
560 003
+91 (0) 80 4906 3555

SHANGHAI

NO. 1619 HU HANG ROAD, XI DU TOWNSHIP
FENG XIAN DISTRICT, SHANGHAI
P.R.C.
201401
+86 21 3756 6696

ARMSTRONG INTEGRATED
ESTABLISHED 1934

ARMSTRONGINTEGRATED.COM

**MAKING
ENERGY
MAKE
SENSE™**