

Series 3SE-DS

2½" Spherical Solids Handling
Double Seal

BARNES®

www.cranepumps.com

1½", 2" & 3" Discharge

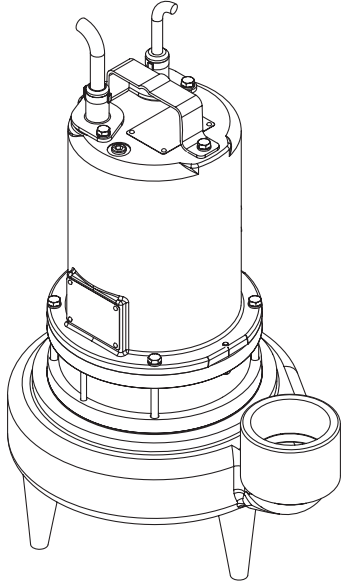

Series: 3SE-DS 1.5 & 2HP, 1750RPM, 60Hz



CSA 108 - File No. L16567

Sample Specifications: Section 1 Page 7.

DESCRIPTION:

SUBMERSIBLE NON-CLOG SEWAGE PUMP
DESIGNED FOR TYPICAL RAW SEWAGE
APPLICATIONS

DISCHARGE	3" NPT, Vertical
LIQUID TEMPERATURE	104°F (40°C) Continuous
VOLUTE	Cast Iron ASTM, Class 30
MOTOR HOUSING	Cast Iron ASTM, Class 30
SEAL PLATE	Cast Iron ASTM A-48, Class 30
IMPELLER: Design	2 Vane, open with pump out vanes on back side. Dynamically balanced, ISO G6.3
<i>Material</i>	Cast Iron, Class 30
SHAFT	416 Stainless Steel
SQUARE RINGS	Buna-N
HARDWARE	300 Series Stainless Steel
PAINT	Air Dry Enamel
SEAL: Design	Tandem Mechanical, Oil filled reservoir
<i>Material</i>	Carbon/Ceramic/Buna-N
<i>Hardware</i>	-300 Series Stainless
CORD ENTRY	30 ft. (9.1m) Cord. Quick connect custom molded for sealing and strain relief
SPEED	1750 RPM (Nominal), 60Hz
UPPER BEARING	Single Row, Ball, Oil lubricated
<i>Load</i>	Radial
LOWER BEARING	Single Row, Ball, Oil lubricated
<i>Load</i>	Radial & Thrust
MOTOR: Design	NEMA L -Single Phase, NEMA B -Three phase Torque Curve, Oil Filled, Squirrel Cage Induction
<i>Insulation</i>	Class B
SINGLE PHASE	Permanent Split Capacitor (PSC) Includes Overload Protection in Motor
THREE PHASE	200-230/460 is Tri-Voltage. 575V. Requires overload Protection to be included in control panel
MOISTURE SENSOR	Normally Open, Requires relay in control panel
TEMPERATURE SENSOR	Normally Closed, Requires relay in control panel. For three phase units ONLY
OPTIONAL EQUIPMENT	Seal Material, Impeller Trims, Additional cord.

RECOMMENDED:

<i>Accessories</i>	Break Away Fitting (BAF) Check Valve Control Panel
<i>Seal Kit PN</i>	130177
<i>Service Kit PN</i>	130173

SECTION 1B
PAGE 60
DATE 9/11

CRANE®

A Crane Co. Company

PUMPS & SYSTEMS

USA: (937) 778-8947 • Canada: (905) 457-6223 • International: (937) 615-3598

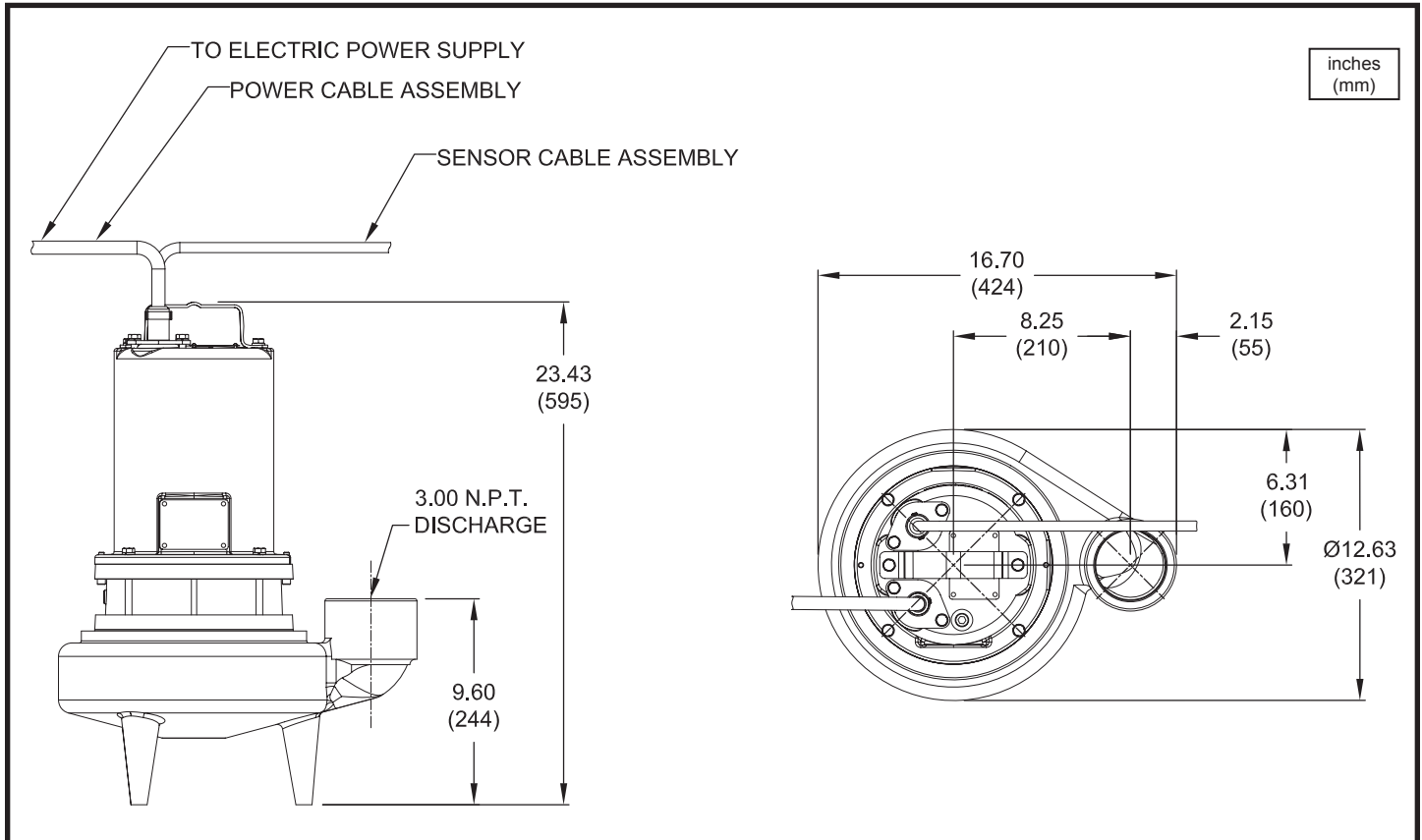

MODEL NO	PART NO	HP	VOLT/PH	Hz	RPM (Nom)	NEMA START CODE	FULL LOAD AMPS	LOCKED ROTOR AMPS	CORD SIZE	CORD TYPE	CORD O.D inch (mm)
3SE1524DS	132745	1.5	230/1	60	1750	C	16.0	44.6	12/3	SOOW / SOW	0.610 (15.5)
3SE1594DS	132758	1.5	200-230/3	60	1750	D/G	13.3/11.6	35.8/41.2	12/4	SOOW / SOW	0.680 (17.4)
3SE1544DS	132760	1.5	460/3	60	1750	G	5.8	20.6	14/4	SOOW / SOW	0.570 (14.5)
3SE1554DS	132761	1.5	575/3	60	1750	G	4.6	16.4	14/4	SOOW / SOW	0.570 (14.5)
3SE2024DS	132765	2.0	230/1	60	1750	A	19.0	44.6	10/3	SOOW / SOW	0.660 (16.8)
3SE2094DS	132768	2.0	200-230/3	60	1750	B/D	15.2/13.2	35.8/41.2	12/4	SOOW / SOW	0.680 (17.4)
3SE2044DS	132770	2.0	460/3	60	1750	D	6.6	20.6	14/4	SOOW / SOW	0.570 (14.5)
3SE2054DS	132772	2.0	575/3	60	1750	D	5.2	16.4	14/4	SOOW / SOW	0.570 (14.5)

Moisture & Temperature sensor cord for all models is 18/5 SOOW/SOW, 0.47 (11.9mm) O.D.
OPTIONAL Temperature only sensor cord for 3 phase models is 14/3 SOOW/SOW, 0.53 (13.5mm) O.D.

IMPORTANT !

- PUMP MAY BE OPERATED "DRY" FOR EXTENDED PERIODS WITHOUT DAMAGE TO MOTOR AND/OR SEALS.
- INSTALLATIONS SUCH AS DECORATIVE FOUNTAINS OR WATER FEATURES PROVIDED FOR VISUAL ENJOYMENT MUST BE INSTALLED IN ACCORDANCE WITH THE NATIONAL ELECTRIC CODE ANSI/NFPA 70 AND/OR THE AUTHORITY HAVING JURISDICTION. THIS PUMP IS NOT INTENDED FOR USE IN SWIMMING POOLS, RECREATIONAL WATER PARKS, OR INSTALLATIONS IN WHICH HUMAN CONTACT WITH PUMPED MEDIA IS A COMMON OCCURRENCE.

Series 3SE-DS

Performance Curve

1.5 & 2.HP, 1750RPM, 60Hz

BARNES®

www.cranepumps.com

1½", 2" & 3" Discharge

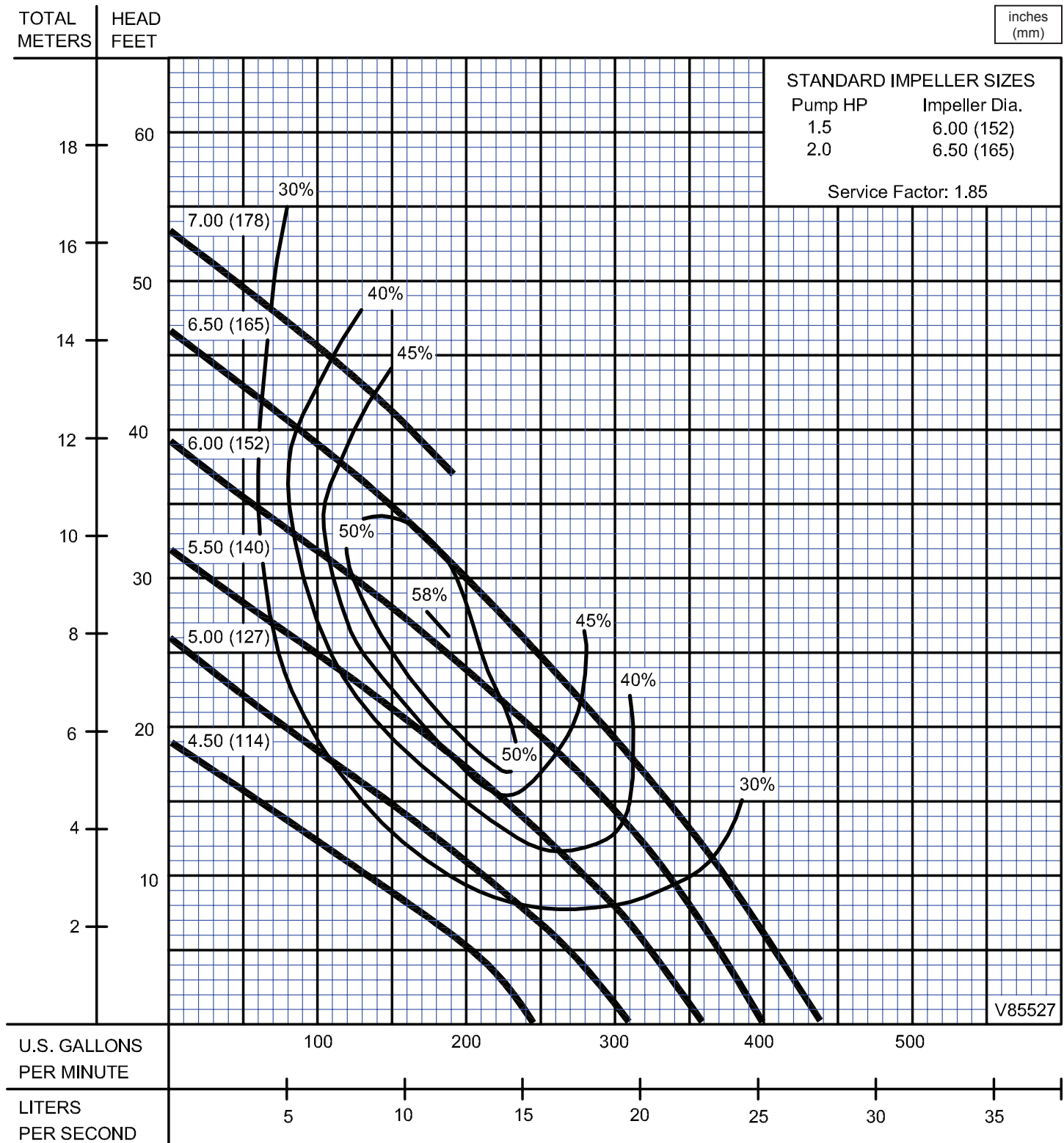

Testing is performed with water, specific gravity 1.0 @ 68° F @ (20°C), other fluids may vary performance

SECTION 1B
PAGE 62
DATE 1/06

CRANE
A Crane Co. Company

PUMPS & SYSTEMS

USA: (937) 778-8947 • Canada: (905) 457-6223 • International: (937) 615-3598