

283HV-3X (B39)

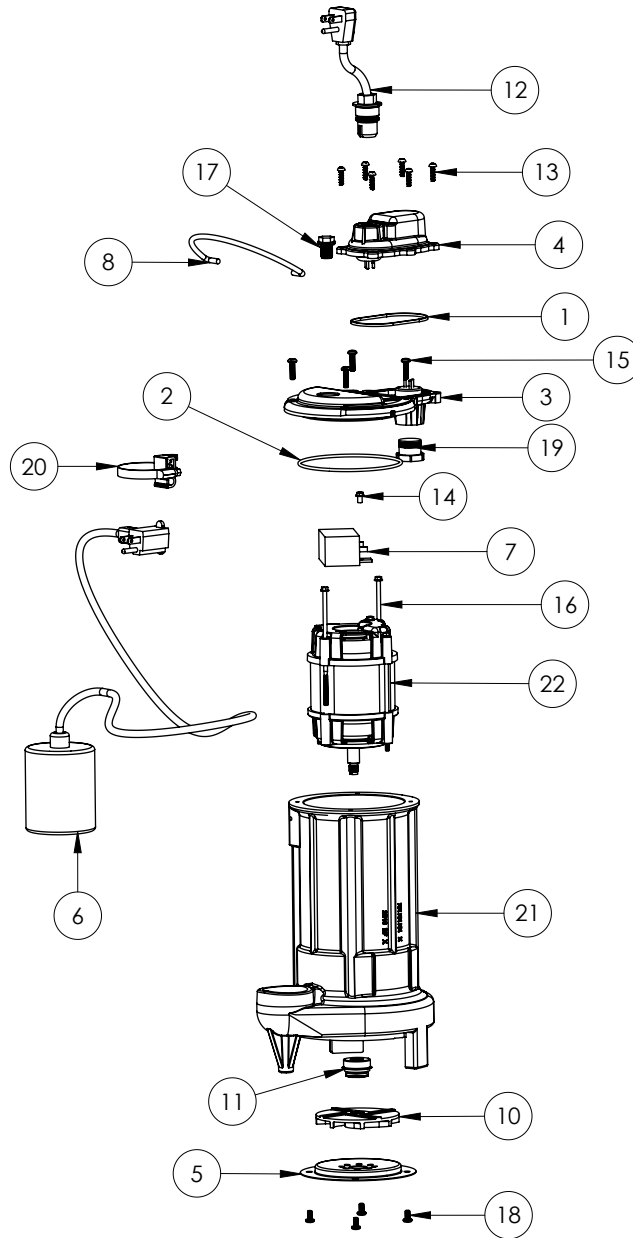

283HV-3X**283HV-3X (B39)**

| # | PART # | DESCRIPTION | QTY | Note |
|----|---------|---------------------------------------|-----|------|
| 1 | K001046 | SEALRING, CHAMBER COVER | 1 | |
| 2 | 2357000 | O-RING | 1 | [1] |
| 3 | 240600B | MOTOR COVER | 1 | |
| 4 | 240700B | CHAMBER COVER | 1 | |
| 5 | 2414000 | 280 SERIES STAMPING INLET | 1 | |
| 6 | 61140C0 | 35' SWITCH, 230V N/O | 1 | |
| 7 | 2455000 | CAPACITOR | 1 | [1] |
| 8 | K001082 | HANDLE | 1 | |
| 10 | K001091 | 280 SERIES IMPELLER KIT | 1 | |
| 11 | 50980A0 | 1/2 INCH UNITIZED SEAL | 1 | [1] |
| 12 | K001344 | POWER CORD, 35FT. | 1 | |
| 13 | 8104200 | #10 HILO X 5/8" STAINLESS STEEL SCREW | 6 | |
| 14 | 8160000 | CAPACITOR SCREW | 1 | [1] |
| 15 | 8072000 | #10 - 24 x 3/4" SCREW | 4 | |
| 16 | 8150000 | #8-32 x 4-7/8" SCREW | 1 | [1] |
| 17 | 8089000 | OIL PLUG, O-RING ASSEMBLY | 1 | |
| 18 | 8092000 | #10 - 24 x 3/8" SCREW | 4 | |
| 19 | 8105000 | PROTECTIVE CAP | 1 | |
| 20 | 5870000 | SWITCH CLAMP | 1 | |
| 21 | 25162CJ | HOUSING | 1 | |
| 22 | 2424200 | MOTOR, .5HP 230V | 1 | [1] |

PART NOTES:

[1] - Part requires factory authorized service. Contact Liberty Pumps at 1-800-543-2550