



Replacement Parts List

304-382

CI 2508

SUPERSEDES: 304-382 February 1, 2003

EFFECTIVE: January 31, 2004

WHEN SELECTING AND ORDERING PARTS, ALWAYS REFER TO SERIAL NUMBER ON NAMEPLATE

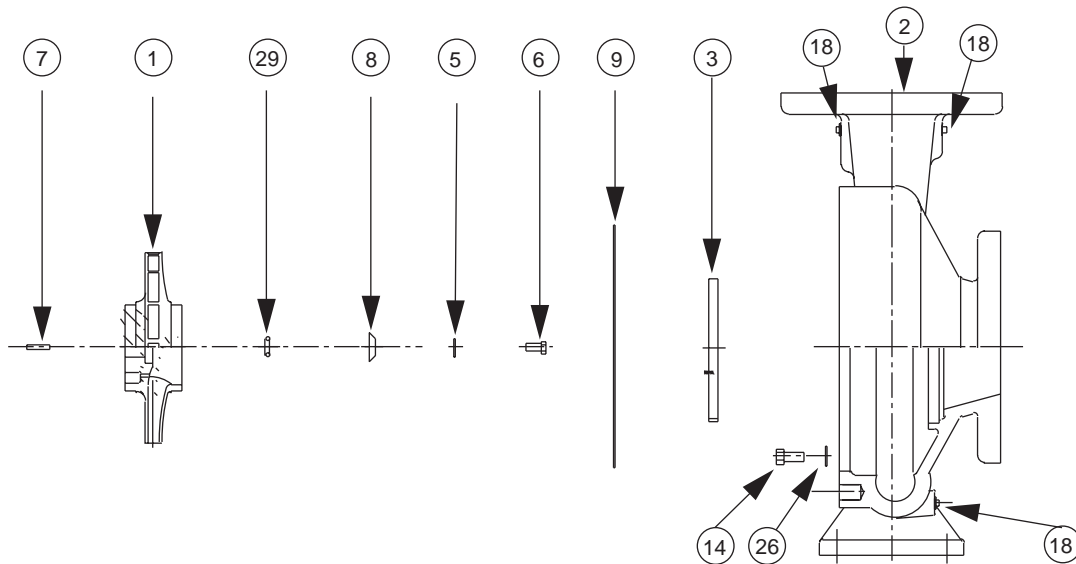
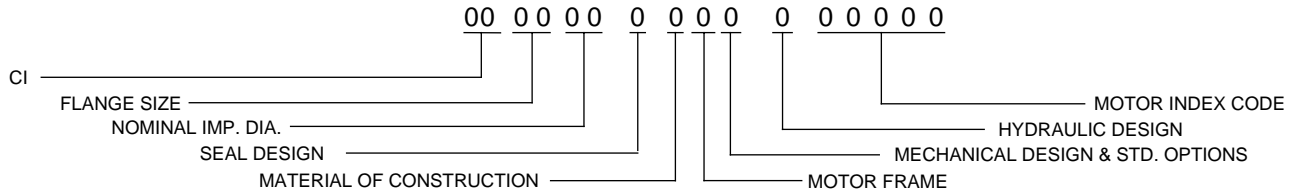

AW-744 REV A

ITEM NO.	NO. REQ.	DESCRIPTION	2508	2508
			FRAME H,J OR K	FRAME L,M DR N
1	1	IMPELLER (CI)	953-2174RP	953-2176RP
1	1	IMPELLER (BRZ)	953-2175RP	953-2177RP
2	1	CASING (125#)(NO WR)	953-2018RP	953-2018RP
2	1	CASING (250#)(NO WR)	953-2019RP	953-2019RP
2	1	CASING (125#)(BRZ W/R)	953-2300RP	953-2300RP
2	1	CASING (250#)(BRZ W/R)	953-2301RP	953-2301RP
3	1(W/R)	WEAR RING (BRZ)	953-1909RP	953-1909RP
5	1	DOWDY WASHER	951-2578RP	951-2579RP
6	1	IMPELLER BOLT (SST)	3/8NCX1 3/4LG	1/2NCX1-1/4LG
7	1	IMPELLER KEY (SST)	3/16X3/16X1-7/8LG	1/4X1/4X2LG
8	1	IMPELLER WASHER	953-828RP	953-829RP
9	1	GASKET (CASING)	953-1009RP	953-1009RP
14	12	CASING BOLT (ST)	3/8NCX7/8LG	3/8NCX7/8LG
18	3	PIPE PLUG (BRZ)	1/4 NPT	1/4 NPT
26	12	CASING WASHER (ZN)	3/8	3/8
29	1	IMPELLER GASKET	953-830RP	953-759RP

CI Series Cover Replacement Parts

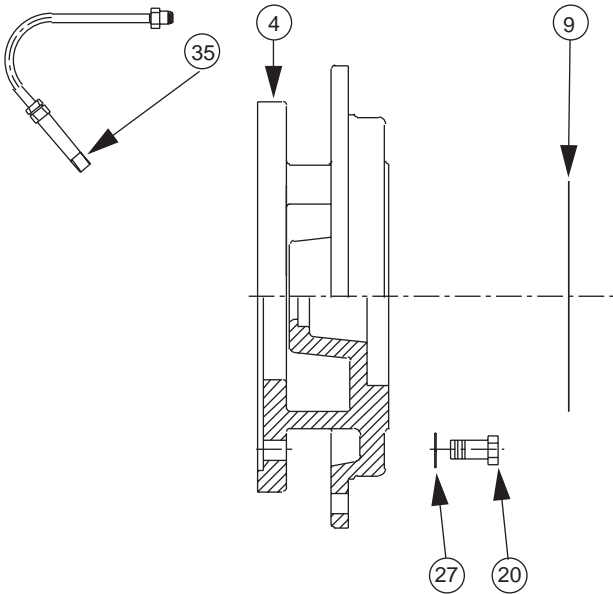

AW-745 REV

ITEM NO.	NO. REQ.	DESCRIPTION	MOTOR FRAME					MODEL NO
			H OR J	K	L	M OR N	R	
4	1	COVER	953-1905RP	953-1906RP	953-1907RP	953-1908RP	-----	2508
9	1	GASKET (CASING)	SEE PAGE 1	SEE PAGE 1	SEE PAGE 1	SEE PAGE 1	-----	
20	4	MOTOR BOLT	3/8NCX1LG	1/2NCX1-1/4LG	1/2NCX1-1/2LG	5/8NCX1-1/4LG	-----	ALL ABOVE
27	4	MOTOR WASHER	3/8	1/2	1/2	5/8	-----	
35	1	TUBE KIT	951-1547RP	951-1547RP	951-1547RP	951-1547RP	-----	

CI Series Seal Replacement Parts

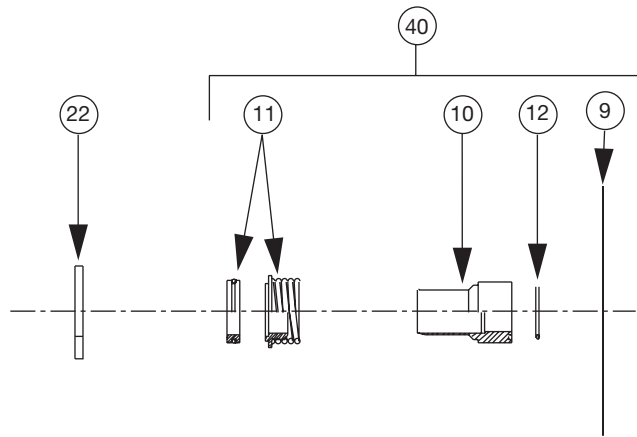

1206, 1506, 2506		1206, 1506, 2506	
1207, 1507, 2007, 2507, 3007, 4075, 4007, 5007	1207, 1507, 2007, 2507, 3007, 4075, 4007, 5007	1207, 1507, 2007, 2507, 3007, 4075, 4007, 5007	1207, 1507, 2007, 2507, 3007, 4075, 4007, 5007
2508	2508	2508	2508
1509, 2009, 2509, 3009, 4009, 5009, 5095, 6009	1509, 2009, 2509, 3009, 4009, 5009, 5095, 6009	1509, 2009, 2509, 3009, 4009, 5009, 5095, 6009	1509, 2009, 2509, 3009, 4009, 5009, 5095, 6009
1511, 2511, 3011, 4011, 5011	1511, 2511, 3011, 4011, 5011, 6011	1511, 2511, 3011, 4011, 5011	1511, 2511, 3011, 4011, 5011, 6011
2510	2510	2510	2510
2513, 3013, 4013, 5013	2513, 3013, 4013, 5013, 6013	2513, 3013, 4013, 5013	2513, 3013, 4013, 5013, 6013

ITEM NO.	NO. REQ.	DESCRIPTION	MOTOR FRAME		MOTOR FRAME	
			H, J OR K	L,M,N OR R	H, J OR K	L,M,N OR R
			MECHANICAL DES. A (125#)		MECHANICAL DES. B (250#)	
9	1	GASKET (CASING)	SEE PAGE 1	SEE PAGE 1	SEE PAGE 1	SEE PAGE 1
10	1	SLEEVE (SS)	953-1118RP	953-1170RP	953-1118RP	953-1170RP
10	1	SLEEVE (BRZ)	953-1119RP	953-1171RP	953-1119RP	953-1171RP
11	1	SEAL (TYPE B)	951-3157RP	951-3158RP	951-3766RP	951-5158RP
11	1	SEAL (TYPE D)	951-3159RP	951-3160RP	951-3781RP	951-5159RP
11	1	SEAL (TYPE E)	951-3161RP	951-3162RP	951-3782RP	951-5160RP
12	1	SLEEVE GASKET	953-830RP	951-3042RP	953-830RP	951-3042RP
22	1	DEFLECTOR	900-044RP	951-3065RP	900-044RP	951-3065RP
40	1	SEAL KIT (TYPE B) SS	953-1549-1RP	953-1549-4RP	953-1549-7RP	953-1549-10RP
40	1	SEAL KIT (TYPE B) BRZ	953-1549-1BRP	953-1549-4BRP	953-1549-7BRP	953-1549-10BRP
40	1	SEAL KIT (TYPE D) SS	953-1549-2RP	953-1549-5RP	953-1549-8RP	953-1549-11RP
40	1	SEAL KIT (TYPE D) BRZ	953-1549-2BRP	953-1549-5BRP	953-1549-8BRP	953-1549-11BRP
40	1	SEAL KIT (TYPE E) SS	953-1549-3RP	953-1549-6RP	953-1549-9RP	953-1549-12RP
40	1	SEAL KIT (TYPE E) BRZ	953-1549-3BRP	953-1549-6BRP	953-1549-9BRP	953-1549-12BRP

AW-687 REV C

Do it Once. Do it Right.™

TACO, INC., 1160 Cranston Street, Cranston, RI 02920 Telephone: (401) 942-8000 FAX: (401) 942-2360.
TACO (Canada), Ltd., 6180 Ordan Drive, Mississauga, Ontario L5T 2B3. Telephone: 905/564-9422. FAX: 905/564-9436.

Visit our web site at: <http://www.taco-hvac.com>

Printed in USA
Copyright 2004
TACO, Inc.