

<b>JOB:</b>	<b>REPRESENTATIVE:</b>	
<b>UNIT TAG:</b>	<b>ORDER NO.</b>	<b>DATE:</b>
<b>ENGINEER:</b>	<b>SUBMITTED BY:</b>	<b>DATE:</b>
<b>CONTRACTOR:</b>	<b>APPROVED BY:</b>	<b>DATE:</b>

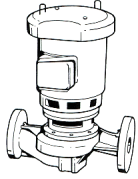

## 2.5x2.5x9.5C

### Series e-80

#### In-Line Mounted Centrifugal Pumps

**SPECIFICATIONS**

FLOW \_\_\_\_\_ HEAD \_\_\_\_\_

HP \_\_\_\_\_ RPM \_\_\_\_\_

VOLTS \_\_\_\_\_

CYCLE \_\_\_\_\_ INPUT PHASE \_\_\_\_\_

ENCLOSURE \_\_\_\_\_

APPROX. WEIGHT \_\_\_\_\_

SPECIALS \_\_\_\_\_

**MATERIALS OF CONSTRUCTION**

Stainless Steel Fitted

**MAXIMUM WORKING PRESSURE**

- 175 psi (12 bar) with 125# ANSI flange drilling
- 250 psi (17 bar) with 250# ANSI flange drilling (requires 80-S)
- 300 psi (21 bar) W.P. with 250# ANSI flange drilling (Requires -S and EPR-Silicon Carbide-Silicon Carbide Seal)

**MOUNTING**

- In-Line Piping
- Flange Supports

**PUMP VARIABLE SPEED CONTROL**

- Integrated Technologic® Sensorless Control (ITSC)
- Integrated Technologic® (IT)
  - External input by others
  - Pressure Sensor(s)
  - Differential Pressure Sensor(s)
  - Flow Sensor(s)
- By Others

**TYPE OF SEAL**

- F Standard Seal w/ Flush Line (Buna-Carbon/Ceramic)
- S Stuffing Box construction w/ Flushed Mechanical Single Seal (EPR-Tungsten Carbide/Carbon)
- PF Stuffing Box Construction w/ Flushed Packing (Graphite Impregnated PTFE)

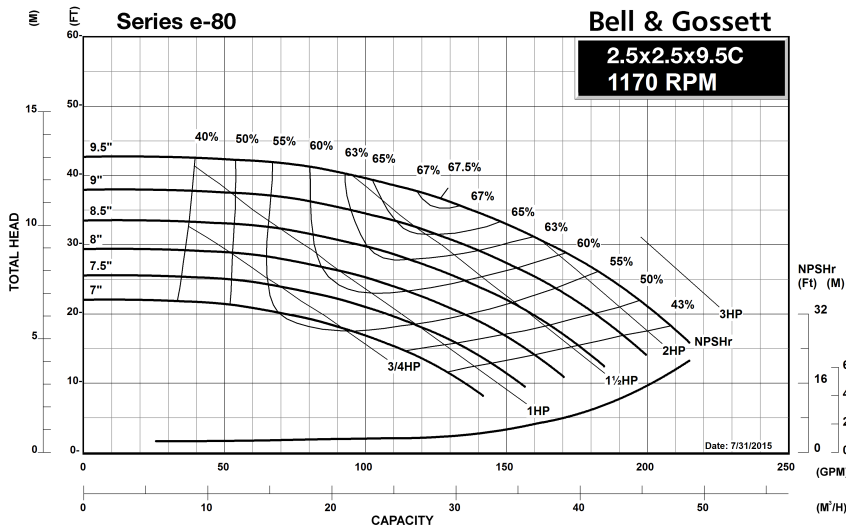

<b>JOB:</b>	<b>REPRESENTATIVE:</b>	
<b>UNIT TAG:</b>	<b>ORDER NO.:</b>	<b>DATE:</b>
<b>ENGINEER:</b>	<b>SUBMITTED BY:</b>	<b>DATE:</b>
<b>CONTRACTOR:</b>	<b>APPROVED BY:</b>	<b>DATE:</b>

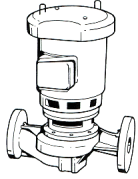

## 2.5x2.5x9.5C

### Series e-80

#### In-Line Mounted Centrifugal Pumps

**SPECIFICATIONS**

FLOW \_\_\_\_\_ HEAD \_\_\_\_\_

HP \_\_\_\_\_ RPM \_\_\_\_\_

VOLTS \_\_\_\_\_

CYCLE \_\_\_\_\_ INPUT PHASE \_\_\_\_\_

ENCLOSURE \_\_\_\_\_

APPROX. WEIGHT \_\_\_\_\_

SPECIALS \_\_\_\_\_

**MATERIALS OF CONSTRUCTION**

Stainless Steel Fitted

**MAXIMUM WORKING PRESSURE**

- 175 psi (12 bar) with 125# ANSI flange drilling
- 250 psi (17 bar) with 250# ANSI flange drilling (requires 80-S)
- 300 psi (21 bar) W.P. with 250# ANSI flange drilling (Requires -S and EPR-Silicon Carbide-Silicon Carbide Seal)

**MOUNTING**

- In-Line Piping
- Flange Supports

**PUMP VARIABLE SPEED CONTROL**

- Integrated Technologic® Sensorless Control (ITSC)
- Integrated Technologic® (IT)
  - External input by others
  - Pressure Sensor(s)
  - Differential Pressure Sensor(s)
  - Flow Sensor(s)
- By Others

**TYPE OF SEAL**

- F Standard Seal w/ Flush Line (Buna-Carbon/Ceramic)
- S Stuffing Box construction w/ Flushed Mechanical Single Seal (EPR-Tungsten Carbide/Carbon)
- PF Stuffing Box Construction w/ Flushed Packing (Graphite Impregnated PTFE)

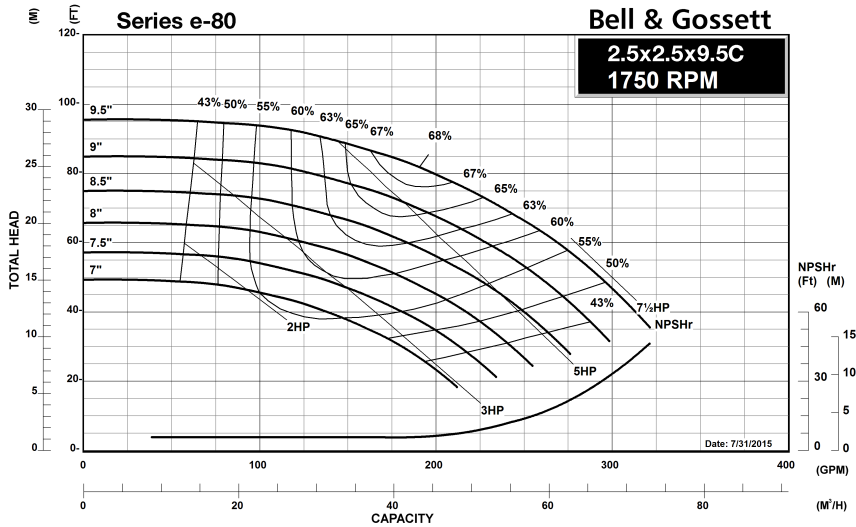

<b>JOB:</b>   <b>UNIT TAG:</b> <b>ENGINEER:</b> <b>CONTRACTOR:</b>	<b>REPRESENTATIVE:</b>   <b>ORDER NO.:</b> <b>SUBMITTED BY:</b> <b>APPROVED BY:</b>	<b>DATE:</b> <b>DATE:</b> <b>DATE:</b>
---	--	--

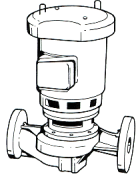

## 2.5x2.5x9.5C

### Series e-80

#### In-Line Mounted Centrifugal Pumps

**SPECIFICATIONS**

FLOW \_\_\_\_\_ HEAD \_\_\_\_\_  
 HP \_\_\_\_\_ RPM \_\_\_\_\_  
 VOLTS \_\_\_\_\_  
 CYCLE \_\_\_\_\_ INPUT PHASE \_\_\_\_\_  
 ENCLOSURE \_\_\_\_\_  
 APPROX. WEIGHT \_\_\_\_\_  
 SPECIALS \_\_\_\_\_

**MATERIALS OF CONSTRUCTION**

Stainless Steel Fitted

**MAXIMUM WORKING PRESSURE**

- 175 psi (12 bar) with 125# ANSI flange drilling
- 250 psi (17 bar) with 250# ANSI flange drilling (requires 80-S)
- 300 psi (21 bar) W.P. with 250# ANSI flange drilling (Requires -S and EPR-Silicon Carbide-Silicon Carbide Seal)

**MOUNTING**

- In-Line Piping
- Flange Supports

**PUMP VARIABLE SPEED CONTROL**

- Integrated Technologic® Sensorless Control (ITSC)
- Integrated Technologic® (IT)
  - External input by others
  - Pressure Sensor(s)
  - Differential Pressure Sensor(s)
  - Flow Sensor(s)
- By Others

**TYPE OF SEAL**

- F Standard Seal w/ Flush Line (Buna-Carbon/Ceramic)
- S Stuffing Box construction w/ Flushed Mechanical Single Seal (EPR-Tungsten Carbide/Carbon)
- PF Stuffing Box Construction w/ Flushed Packing (Graphite Impregnated PTFE)

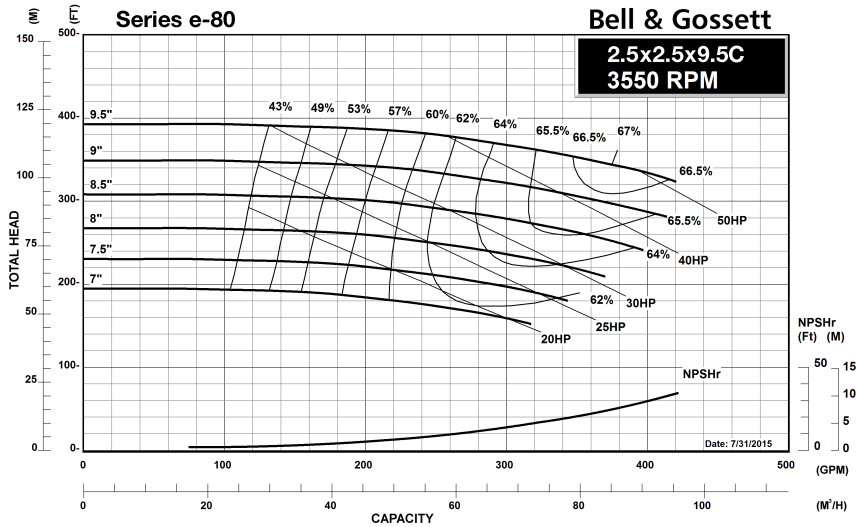

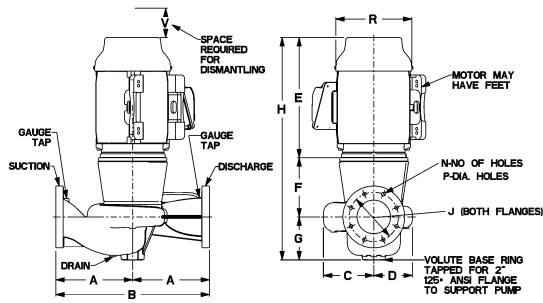

# 2.5x2.5x9.5C Series e-80 Centrifugal Pump Submittal - In-Line Piping

**DIMENSIONS - Inches (mm)**

**STANDARD SEAL**

MOTOR FRAME	A	B	C	D	E (max)	F	G	H (max)	125# ANSI			250# ANSI			R	S (Max)*	V (min)	Suct/Disch Gauge Taps (NPT)	Drain Tap (NPT)
									J	N	P	J	N	P					
145JM	10.75 (273)	21.50 (546)	5.96 (151)	7.06 (179)	12.63 (321)	4.81 (122)	6.00 (152)	23.44 (595)	5.50 (140)	4	0.75 (19)	5.88 (149)	8	0.88 (22)	9.75 (248)	1.50 (38)	4.75 (121)	0.25	0.25
182JM	10.75 (273)	21.50 (546)	5.96 (151)	7.06 (179)	15.31 (389)	4.81 (122)	6.00 (152)	26.13 (664)	5.50 (140)	4	0.75 (19)	5.88 (149)	8	0.88 (22)	11.75 (298)	1.00 (25)	4.75 (121)	0.25	0.25
184JM	10.75 (273)	21.50 (546)	5.96 (151)	7.06 (179)	15.31 (389)	4.81 (122)	6.00 (152)	26.13 (664)	5.50 (140)	4	0.75 (19)	5.88 (149)	8	0.88 (22)	11.75 (298)	1.00 (25)	4.75 (121)	0.25	0.25
213JM	10.75 (273)	21.50 (546)	5.96 (151)	7.06 (179)	19.25 (489)	4.81 (122)	6.00 (152)	30.06 (764)	5.50 (140)	4	0.75 (19)	5.88 (149)	8	0.88 (22)	14.00 (356)	-	4.75 (121)	0.25	0.25
215JM	10.75 (273)	21.50 (546)	5.96 (151)	7.06 (179)	19.25 (489)	4.81 (122)	6.00 (152)	30.06 (764)	5.50 (140)	4	0.75 (19)	5.88 (149)	8	0.88 (22)	14.00 (356)	-	4.75 (121)	0.25	0.25
254JM	10.75 (273)	21.50 (546)	5.96 (151)	7.06 (179)	24.13 (613)	5.81 (148)	6.00 (152)	35.94 (913)	5.50 (140)	4	0.75 (19)	5.88 (149)	8	0.88 (22)	17.00 (432)	-	4.75 (121)	0.25	0.25
256JM	10.75 (273)	21.50 (546)	5.96 (151)	7.06 (179)	24.13 (613)	5.81 (148)	6.00 (152)	35.94 (913)	5.50 (140)	4	0.75 (19)	5.88 (149)	8	0.88 (22)	17.00 (432)	-	4.75 (121)	0.25	0.25
284JM	10.75 (273)	21.50 (546)	5.96 (151)	7.06 (179)	23.63 (600)	5.81 (148)	6.00 (152)	35.44 (900)	5.50 (140)	4	0.75 (19)	5.88 (149)	8	0.88 (22)	16.13 (410)	4.63 (117)	4.75 (121)	0.25	0.25
286JM	10.75 (273)	21.50 (546)	5.96 (151)	7.06 (179)	25.13 (638)	5.81 (148)	6.00 (152)	36.94 (938)	5.50 (140)	4	0.75 (19)	5.88 (149)	8	0.88 (22)	16.13 (410)	4.63 (117)	4.75 (121)	0.25	0.25
324JM	10.75 (273)	21.50 (546)	5.96 (151)	7.06 (179)	26.00 (660)	5.81 (148)	6.00 (152)	37.81 (960)	5.50 (140)	4	0.75 (19)	5.88 (149)	8	0.88 (22)	18.75 (476)	5.38 (137)	4.75 (121)	0.25	0.25
326JM	10.75 (273)	21.50 (546)	5.96 (151)	7.06 (179)	26.00 (660)	5.81 (148)	6.00 (152)	37.81 (960)	5.50 (140)	4	0.75 (19)	5.88 (149)	8	0.88 (22)	18.75 (476)	5.38 (137)	4.75 (121)	0.25	0.25

**STUFFING BOX**

MOTOR FRAME	A	B	C	D	E (max)	F	G	H (max)	125# ANSI			250# ANSI			R	S (Max)*	V (min)	Suct/Disch Gauge Taps (NPT)	Drain Tap (NPT)
									J	N	P	J	N	P					
145JP	10.75 (273)	21.50 (546)	5.96 (151)	7.06 (179)	12.63 (321)	7.94 (202)	6.00 (152)	26.56 (675)	5.50 (140)	4	0.75 (19)	5.88 (149)	8	0.88 (22)	9.75 (248)	1.50 (38)	4.75 (121)	0.25	0.25
182JP	10.75 (273)	21.50 (546)	5.96 (151)	7.06 (179)	15.31 (389)	7.94 (202)	6.00 (152)	29.25 (743)	5.50 (140)	4	0.75 (19)	5.88 (149)	8	0.88 (22)	11.75 (298)	1.00 (25)	4.75 (121)	0.25	0.25
184JP	10.75 (273)	21.50 (546)	5.96 (151)	7.06 (179)	15.31 (389)	7.94 (202)	6.00 (152)	29.25 (743)	5.50 (140)	4	0.75 (19)	5.88 (149)	8	0.88 (22)	11.75 (298)	1.00 (25)	4.75 (121)	0.25	0.25
213JP	10.75 (273)	21.50 (546)	5.96 (151)	7.06 (179)	19.25 (489)	8.69 (221)	6.00 (152)	33.94 (862)	5.50 (140)	4	0.75 (19)	5.88 (149)	8	0.88 (22)	14.00 (356)	-	4.75 (121)	0.25	0.25
215JP	10.75 (273)	21.50 (546)	5.96 (151)	7.06 (179)	19.25 (489)	8.69 (221)	6.00 (152)	33.94 (862)	5.50 (140)	4	0.75 (19)	5.88 (149)	8	0.88 (22)	14.00 (356)	-	4.75 (121)	0.25	0.25
254JP	10.75 (273)	21.50 (546)	5.96 (151)	7.06 (179)	24.13 (613)	8.69 (221)	6.00 (152)	38.81 (986)	5.50 (140)	4	0.75 (19)	5.88 (149)	8	0.88 (22)	17.00 (432)	-	4.75 (121)	0.25	0.25
256JP	10.75 (273)	21.50 (546)	5.96 (151)	7.06 (179)	24.13 (613)	8.69 (221)	6.00 (152)	38.81 (986)	5.50 (140)	4	0.75 (19)	5.88 (149)	8	0.88 (22)	17.00 (432)	-	4.75 (121)	0.25	0.25
284JP	10.75 (273)	21.50 (546)	5.96 (151)	7.06 (179)	23.63 (600)	8.69 (221)	6.00 (152)	38.31 (973)	5.50 (140)	4	0.75 (19)	5.88 (149)	8	0.88 (22)	16.13 (410)	4.63 (117)	4.75 (121)	0.25	0.25
286JP	10.75 (273)	21.50 (546)	5.96 (151)	7.06 (179)	25.13 (638)	8.69 (221)	6.00 (152)	39.81 (1011)	5.50 (140)	4	0.75 (19)	5.88 (149)	8	0.88 (22)	16.13 (410)	4.63 (117)	4.75 (121)	0.25	0.25
324JP	10.75 (273)	21.50 (546)	5.96 (151)	7.06 (179)	26.00 (660)	8.69 (221)	6.00 (152)	40.69 (1033)	5.50 (140)	4	0.75 (19)	5.88 (149)	8	0.88 (22)	18.75 (476)	5.38 (137)	4.75 (121)	0.25	0.25
326JP	10.75 (273)	21.50 (546)	5.96 (151)	7.06 (179)	26.00 (660)	8.69 (221)	6.00 (152)	40.69 (1033)	5.50 (140)	4	0.75 (19)	5.88 (149)	8	0.88 (22)	18.75 (476)	5.38 (137)	4.75 (121)	0.25	0.25

Dimensions are subject to change. Not to be used for construction purposes unless certified.

NOTE: For Single phase Motors add 1" to dimensions E & H.

\*Dimensions are for ODP Motors. For TEFC add S dimension to dimensions E & H.

Xylem Inc.  
8200 N. Austin Avenue, Morton Grove, IL 60053  
Phone: (847)966-3700 Fax: (847)965-8379  
www.bellgossett.com  
Bell & Gossett is a trademark of Xylem Inc. or one of its subsidiaries.  
© 2015 Xylem Inc.



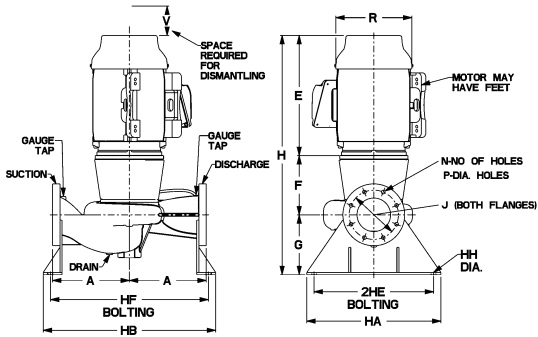

# 2.5x2.5x9.5C Series e-80 Centrifugal Pump Submittal - Flange Support Mounting

**DIMENSIONS - Inches (mm)**

**STANDARD SEAL**

MOTOR FRAME	A	HF BOLTING	HB	2HE BOLTING	HA	HH DIA	E (max)	F	G	H (max)	125# ANSI			250# ANSI			R	S (Max)*	V (min)	Suct/Disch Gauge Taps (NPT)	Drain Tap (NPT)
											J	N	P	J	N	P					
145JM	10.75 (273)	23.73 (603)	27.23 (692)	21.50 (546)	25.00 (635)	0.88 (22)	12.63 (321)	4.81 (122)	6.00 (152)	23.44 (595)	5.50 (140)	4 (19)	0.75 (19)	5.88 (149)	8 (22)	0.88 (22)	9.75 (248)	1.50 (38)	4.75 (121)	0.25	0.25
182JM	10.75 (273)	23.73 (603)	27.23 (692)	21.50 (546)	25.00 (635)	0.88 (22)	15.31 (389)	4.81 (122)	6.00 (152)	26.13 (664)	5.50 (140)	4 (19)	0.75 (19)	5.88 (149)	8 (22)	0.88 (22)	11.75 (298)	1.00 (25)	4.75 (121)	0.25	0.25
184JM	10.75 (273)	23.73 (603)	27.23 (692)	21.50 (546)	25.00 (635)	0.88 (22)	15.31 (389)	4.81 (122)	6.00 (152)	26.13 (664)	5.50 (140)	4 (19)	0.75 (19)	5.88 (149)	8 (22)	0.88 (22)	11.75 (298)	1.00 (25)	4.75 (121)	0.25	0.25
213JM	10.75 (273)	23.73 (603)	27.23 (692)	21.50 (546)	25.00 (635)	0.88 (22)	19.25 (489)	4.81 (122)	6.00 (152)	30.06 (764)	5.50 (140)	4 (19)	0.75 (19)	5.88 (149)	8 (22)	0.88 (22)	14.00 (356)	-	4.75 (121)	0.25	0.25
215JM	10.75 (273)	23.73 (603)	27.23 (692)	21.50 (546)	25.00 (635)	0.88 (22)	19.25 (489)	4.81 (122)	6.00 (152)	30.06 (764)	5.50 (140)	4 (19)	0.75 (19)	5.88 (149)	8 (22)	0.88 (22)	14.00 (356)	-	4.75 (121)	0.25	0.25
254JM	10.75 (273)	23.73 (603)	27.23 (692)	21.50 (546)	25.00 (635)	0.88 (22)	24.13 (613)	5.81 (148)	6.00 (152)	35.94 (913)	5.50 (140)	4 (19)	0.75 (19)	5.88 (149)	8 (22)	0.88 (22)	17.00 (432)	-	4.75 (121)	0.25	0.25
256JM	10.75 (273)	23.73 (603)	27.23 (692)	21.50 (546)	25.00 (635)	0.88 (22)	24.13 (613)	5.81 (148)	6.00 (152)	35.94 (913)	5.50 (140)	4 (19)	0.75 (19)	5.88 (149)	8 (22)	0.88 (22)	17.00 (432)	-	4.75 (121)	0.25	0.25
284JM	10.75 (273)	23.73 (603)	27.23 (692)	21.50 (546)	25.00 (635)	0.88 (22)	23.63 (600)	5.81 (148)	6.00 (152)	35.44 (900)	5.50 (140)	4 (19)	0.75 (19)	5.88 (149)	8 (22)	0.88 (22)	16.13 (410)	4.63 (117)	4.75 (121)	0.25	0.25
286JM	10.75 (273)	23.73 (603)	27.23 (692)	21.50 (546)	25.00 (635)	0.88 (22)	25.13 (638)	5.81 (148)	6.00 (152)	36.94 (938)	5.50 (140)	4 (19)	0.75 (19)	5.88 (149)	8 (22)	0.88 (22)	16.13 (410)	4.63 (117)	4.75 (121)	0.25	0.25
324JM	10.75 (273)	23.73 (603)	27.23 (692)	21.50 (546)	25.00 (635)	0.88 (22)	26.00 (660)	5.81 (148)	6.00 (152)	37.81 (960)	5.50 (140)	4 (19)	0.75 (19)	5.88 (149)	8 (22)	0.88 (22)	18.75 (476)	5.38 (137)	4.75 (121)	0.25	0.25
326JM	10.75 (273)	23.73 (603)	27.23 (692)	21.50 (546)	25.00 (635)	0.88 (22)	26.00 (660)	5.81 (148)	6.00 (152)	37.81 (960)	5.50 (140)	4 (19)	0.75 (19)	5.88 (149)	8 (22)	0.88 (22)	18.75 (476)	5.38 (137)	4.75 (121)	0.25	0.25

**STUFFING BOX**

MOTOR FRAME	A	HF BOLTING	HB	2HE BOLTING	HA	HH DIA	E (max)	F	G	H (max)	125# ANSI			250# ANSI			R	S (Max)*	V (min)	Suct/Disch Gauge Taps (NPT)	Drain Tap (NPT)
											J	N	P	J	N	P					
145JP	10.75 (273)	23.73 (603)	27.23 (692)	21.50 (546)	25.00 (635)	0.88 (22)	12.63 (321)	7.94 (202)	6.00 (152)	26.56 (675)	5.50 (140)	4 (19)	0.75 (19)	5.88 (149)	8 (22)	0.88 (22)	9.75 (248)	1.50 (38)	4.75 (121)	0.25	0.25
182JP	10.75 (273)	23.73 (603)	27.23 (692)	21.50 (546)	25.00 (635)	0.88 (22)	15.31 (389)	7.94 (202)	6.00 (152)	29.25 (743)	5.50 (140)	4 (19)	0.75 (19)	5.88 (149)	8 (22)	0.88 (22)	11.75 (298)	1.00 (25)	4.75 (121)	0.25	0.25
184JP	10.75 (273)	23.73 (603)	27.23 (692)	21.50 (546)	25.00 (635)	0.88 (22)	15.31 (389)	7.94 (202)	6.00 (152)	29.25 (743)	5.50 (140)	4 (19)	0.75 (19)	5.88 (149)	8 (22)	0.88 (22)	11.75 (298)	1.00 (25)	4.75 (121)	0.25	0.25
213JP	10.75 (273)	23.73 (603)	27.23 (692)	21.50 (546)	25.00 (635)	0.88 (22)	19.25 (489)	8.69 (221)	6.00 (152)	33.94 (862)	5.50 (140)	4 (19)	0.75 (19)	5.88 (149)	8 (22)	0.88 (22)	14.00 (356)	-	4.75 (121)	0.25	0.25
215JP	10.75 (273)	23.73 (603)	27.23 (692)	21.50 (546)	25.00 (635)	0.88 (22)	19.25 (489)	8.69 (221)	6.00 (152)	33.94 (862)	5.50 (140)	4 (19)	0.75 (19)	5.88 (149)	8 (22)	0.88 (22)	14.00 (356)	-	4.75 (121)	0.25	0.25
254JP	10.75 (273)	23.73 (603)	27.23 (692)	21.50 (546)	25.00 (635)	0.88 (22)	24.13 (613)	8.69 (221)	6.00 (152)	38.81 (986)	5.50 (140)	4 (19)	0.75 (19)	5.88 (149)	8 (22)	0.88 (22)	17.00 (432)	-	4.75 (121)	0.25	0.25
256JP	10.75 (273)	23.73 (603)	27.23 (692)	21.50 (546)	25.00 (635)	0.88 (22)	24.13 (613)	8.69 (221)	6.00 (152)	38.81 (986)	5.50 (140)	4 (19)	0.75 (19)	5.88 (149)	8 (22)	0.88 (22)	17.00 (432)	-	4.75 (121)	0.25	0.25
284JP	10.75 (273)	23.73 (603)	27.23 (692)	21.50 (546)	25.00 (635)	0.88 (22)	23.63 (600)	8.69 (221)	6.00 (152)	38.31 (973)	5.50 (140)	4 (19)	0.75 (19)	5.88 (149)	8 (22)	0.88 (22)	16.13 (410)	4.63 (117)	4.75 (121)	0.25	0.25
286JP	10.75 (273)	23.73 (603)	27.23 (692)	21.50 (546)	25.00 (635)	0.88 (22)	25.13 (638)	8.69 (221)	6.00 (152)	39.81 (1011)	5.50 (140)	4 (19)	0.75 (19)	5.88 (149)	8 (22)	0.88 (22)	16.13 (410)	4.63 (117)	4.75 (121)	0.25	0.25
324JM	10.75 (273)	23.73 (603)	27.23 (692)	21.50 (546)	25.00 (635)	0.88 (22)	26.00 (660)	8.69 (221)	6.00 (152)	40.69 (1033)	5.50 (140)	4 (19)	0.75 (19)	5.88 (149)	8 (22)	0.88 (22)	18.75 (476)	5.38 (137)	4.75 (121)	0.25	0.25
326JM	10.75 (273)	23.73 (603)	27.23 (692)	21.50 (546)	25.00 (635)	0.88 (22)	26.00 (660)	8.69 (221)	6.00 (152)	40.69 (1033)	5.50 (140)	4 (19)	0.75 (19)	5.88 (149)	8 (22)	0.88 (22)	18.75 (476)	5.38 (137)	4.75 (121)	0.25	0.25

Dimensions are subject to change. Not to be used for construction purposes unless certified.

NOTE: For Single phase Motors add 1" to dimensions E & H.

\*Dimensions are for ODP Motors. For TEFC add S dimension to dimensions E & H.

Xylem Inc.  
8200 N. Austin Avenue, Morton Grove, IL 60053  
Phone: (847)966-3700 Fax: (847)965-8379  
www.bellgossett.com  
Bell & Gossett is a trademark of Xylem Inc. or one of its subsidiaries.  
© 2015 Xylem Inc.



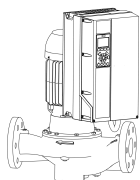

# 2.5x2.5x9.5C Series e-80 In-Line Mounted Centrifugal Pumps With Integrated Technologic® Control

TECHNOLOGIC STANDARD FEATURES	
CONTROL METHOD WITH INTEGRATED TECHNOLOGIC® SENSORLESS CONTROL (ITSC)	Factory configured for sensorless operation.
CONTROL METHOD WITH INTEGRATED TECHNOLOGIC® (IT)	Field configurable for sensor by others, building management system input, or optional sensor(s) provided.
ENCLOSURE	NEMA 12 (same as IP55 & UL type 12)
POWER DISCONNECT SWITCH	Included standard. Fused Disconnect Switch optional with three phase input voltage.
HARMONIC SUPPRESSION	Integrated non-saturating dual DC link reactors provide better harmonic performance than a 5% AC line reactor.
COOLING	Fan-cooled through temperature controlled and easy replacement.
AMBIENT TEMPERATURE RATING	14°F to 113°F (-10°C to 45°C)
COMMUNICATION PROTOCOLS	BACnet, Modbus RTU, N2 Metasys, FLN Apogee
ANALOG INPUTS	2 configurable for either voltage (0 to 10VDC) or current(0/4 to 20mA)
ANALOG OUTPUTS	1 (0/4 to 20mA) up to 500 ohm load accurate to 1% of full scale
DIGITAL INPUTS	4 (0 to 24VDC), NPN or PNP, 0 to 24VDC, on 5 msec scan interval, Up to 2 can be configured as pulse inputs.
DIGITAL OUTPUTS	2 (0 to 24VDC), 40mA max current, configurable as pulse outputs.
RELAY OUTPUTS	2 programmable, 240VAC or 400VAC up to 2 A
MINIMUM CONTROL HEAD	_____ ft (default set to 40% of design head if not unknown)

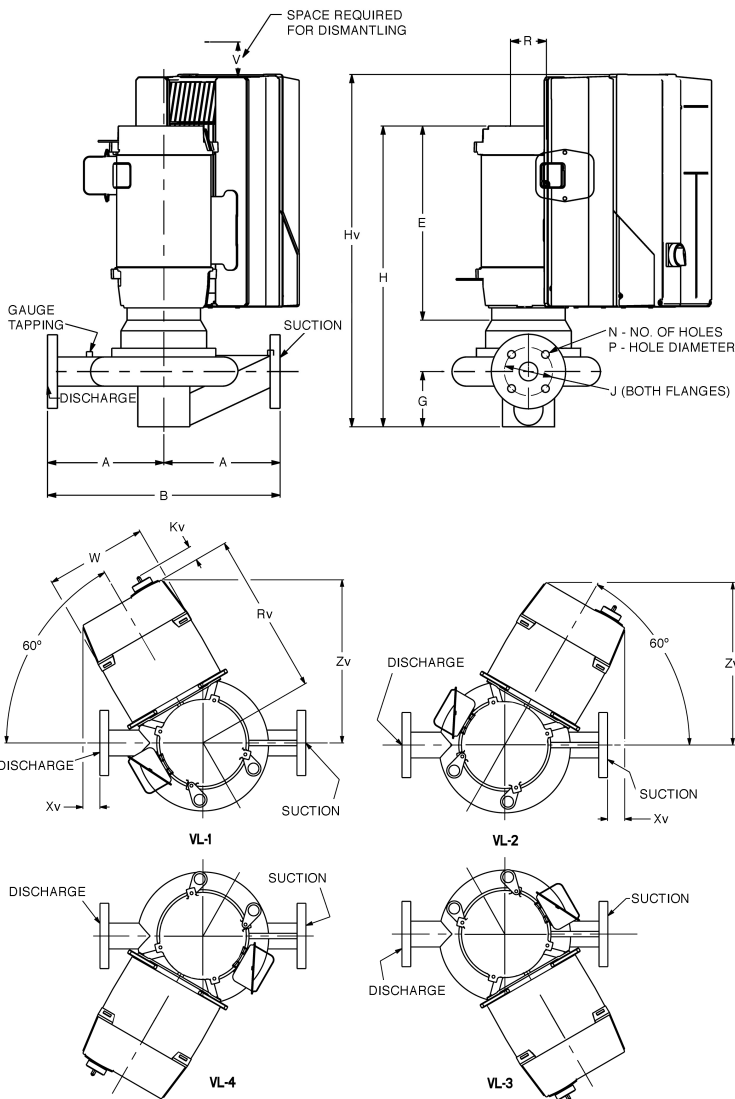

Xylem Inc.  
8200 N. Austin Avenue  
Morton Grove, IL 60053  
Phone: (847)966-3700 Fax: (847)965-8379  
www.bellgossett.com  
Bell & Gossett is a trademark of Xylem Inc. or one of its subsidiaries.  
© 2015 Xylem Inc.

**xylem**  
Let's Solve Water

# Series e-80 2.5x2.5x9.5C

B-139.10

## In-Line Mounted Centrifugal Pumps With Integrated Technologic® Control

**DIMENSIONS - Inches (mm)**

**STANDARD SEAL**

**STUFFING BOX**

MOTOR FRAME	VFD	Rv	Zv	W	Hv	Xv	MOTOR FRAME	VFD	Rv	Zv	W	Hv	Xv
145JM	A5	11.78 (299)	12.31 (313)	9.50 (241)	30.14 (766)	1.19 (30)	145JP	A5	11.78 (299)	12.31 (313)	9.50 (241)	33.27 (845)	1.19 (30)
	B1	14.07 (357)	13.91 (353)	9.50 (241)	32.49 (825)	2.79 (71)		B1	14.07 (357)	13.91 (353)	9.50 (241)	35.62 (905)	2.79 (71)
182JM	A5	12.78 (325)	13.19 (335)	9.50 (241)	29.28 (744)	0.69 (17)	182JP	A5	12.78 (325)	13.19 (335)	9.50 (241)	32.41 (823)	0.69 (17)
	B1	15.07 (383)	14.79 (376)	9.50 (241)	30.28 (769)	2.29 (58)		B1	15.07 (383)	14.79 (376)	9.50 (241)	33.41 (849)	2.29 (58)
184JM	A5	12.78 (325)	13.19 (335)	9.50 (241)	29.28 (744)	0.69 (17)	184JP	A5	12.78 (325)	13.19 (335)	9.50 (241)	32.41 (823)	0.69 (17)
	B1	15.07 (383)	14.79 (376)	9.50 (241)	30.28 (769)	2.29 (58)		B1	15.07 (383)	14.79 (376)	9.50 (241)	33.41 (849)	2.29 (58)
213JM	A5	13.53 (344)	13.83 (351)	9.50 (241)	32.70 (831)	0.31 (8)	213JP	A5	13.53 (344)	13.83 (351)	9.50 (241)	36.58 (929)	0.31 (8)
	B1	15.84 (402)	15.84 (402)	9.50 (241)	34.30 (871)	0.88 (22)		B1	15.84 (402)	15.84 (402)	9.50 (241)	38.17 (970)	0.88 (22)
	B2	15.84 (402)	15.84 (402)	9.50 (241)	40.04 (1017)	0.88 (22)		B2	15.84 (402)	15.84 (402)	9.50 (241)	43.91 (1115)	2.48 (63)
215JM	A5	13.53 (344)	13.83 (351)	9.50 (241)	31.23 (793)	0.31 (8)	215JP	A5	13.53 (344)	13.83 (351)	9.50 (241)	35.11 (892)	0.31 (8)
	B1	15.84 (402)	15.84 (402)	9.50 (241)	32.77 (832)	0.88 (22)		B1	15.84 (402)	15.84 (402)	9.50 (241)	36.64 (931)	0.88 (22)
	B2	15.84 (402)	15.84 (402)	9.50 (241)	38.51 (978)	0.88 (22)		B2	15.84 (402)	15.84 (402)	9.50 (241)	42.38 (1076)	0.88 (22)
	C1	17.81 (452)	19.04 (484)	12.10 (307)	40.53 (1029)	4.08 (104)		C1	17.81 (452)	19.04 (484)	12.10 (307)	44.40 (1128)	4.08 (104)
254JM	-	-	-	-	-	-	254JP	-	-	-	-	-	-
256JM	B1	16.83 (427)	16.70 (424)	9.50 (241)	38.38 (975)	1.38 (35)	256JP	B1	16.83 (427)	16.70 (424)	9.50 (241)	41.25 (1048)	1.38 (35)
	B2	16.83 (427)	16.70 (424)	9.50 (241)	42.84 (1088)	1.38 (35)		B2	16.83 (427)	16.70 (424)	9.50 (241)	45.71 (1161)	1.38 (35)
	C1	18.83 (478)	18.97 (482)	12.09 (307)	43.72 (1110)	3.28 (83)		C1	18.83 (478)	18.97 (482)	12.09 (307)	46.59 (1183)	3.28 (83)
	C2	19.61 (498)	(21) (540)	14.59 (371)	48.38 (1229)	5.58 (142)		C2	19.61 (498)	(21) (540)	14.59 (371)	51.25 (1302)	5.58 (142)
284JM	B1	17.58 (446)	17.36 (441)	9.50 (241)	37.75 (959)	1.75 (44)	284JP	B1	17.58 (446)	17.36 (441)	9.50 (241)	40.63 (1032)	1.75 (44)
	B2	17.58 (446)	17.36 (441)	9.50 (241)	42.20 (1072)	1.75 (44)		B2	17.58 (446)	17.36 (441)	9.50 (241)	45.08 (1145)	1.75 (44)
	C1	19.58 (497)	19.63 (498)	12.09 (307)	44.61 (1133)	3.66 (93)		C1	19.58 (497)	19.63 (498)	12.09 (307)	47.48 (1206)	3.66 (93)
	C2	20.36 (517)	(22) (557)	14.59 (371)	47.76 (1213)	5.96 (151)		C2	20.36 (517)	(22) (557)	14.59 (371)	50.63 (1286)	5.96 (151)
286JM	B2	17.58 (446)	17.36 (441)	9.50 (241)	43.70 (1110)	1.75 (44)	286JP	B2	17.58 (446)	17.36 (441)	9.50 (241)	46.58 (1183)	1.75 (44)
	C1	19.58 (497)	19.63 (498)	12.09 (307)	46.11 (1171)	3.66 (93)		C1	19.58 (497)	19.63 (498)	12.09 (307)	48.98 (1244)	3.66 (93)
	C2	20.36 (517)	(22) (557)	14.59 (371)	49.26 (1251)	5.96 (151)		C2	20.36 (517)	(22) (557)	14.59 (371)	52.13 (1324)	5.96 (151)
324JM	B2	18.58 (472)	18.22 (463)	9.50 (241)	43.05 (1093)	2.25 (57)	324JP	B2	18.58 (472)	18.22 (463)	9.50 (241)	45.92 (1166)	2.25 (57)
	C1	20.58 (523)	20.48 (520)	12.09 (307)	43.39 (1102)	4.16 (106)		C1	20.58 (523)	20.48 (520)	12.09 (307)	46.27 (1175)	4.16 (106)
	C2	21.58 (548)	21.95 (558)	14.59 (371)	47.95 (1218)	5.69 (144)		C2	21.58 (548)	21.95 (558)	14.59 (371)	50.83 (1291)	5.69 (144)
326JM	C1	20.58 (523)	20.48 (520)	12.09 (307)	43.39 (1102)	4.16 (106)	326JP	C1	20.58 (523)	20.48 (520)	12.09 (307)	46.27 (1175)	4.16 (106)
	C2	21.58 (548)	21.95 (558)	14.59 (371)	47.95 (1218)	5.69 (144)		C2	21.58 (548)	21.95 (558)	14.59 (371)	50.83 (1291)	5.69 (144)

NOTE: Drives with single phase input have three phase output and include three phase motors.

Kv=2 (50)

Xylem Inc.  
8200 N. Austin Avenue, Morton Grove, IL 60053  
Phone: (847)966-3700 Fax: (847)965-8379  
www.bellgossett.com  
Bell & Gossett is a trademark of Xylem Inc. or one of its subsidiaries.  
© 2015 Xylem Inc.





# Pressure Sensor/Transmitter For Pumps with TECHNOLOGIC® Drives

## FEATURES

- 4-20mA output
- 10-28 VDC supply voltage
- Operating Temperature -40 to 85°C (-40 to 185°F)
- Storage Temperature -40 to 100°C (-40 to 212°F)
- Enclosure IP-66 (housing only)
- High Strength Stainless Steel Construction
- No Oil, Welds or Internal O-rings
- Wide Operating Temperature
- Low Static and Thermal Errors
- Compatible with Wide Variety of Liquids and Gases
- EMI/RFI Protection
- UL/cUL 508 Approved (with housing)
- 1lb. (0.45 kg) approximate weight

## TECHNOLOGIC ANALOG SENSOR WIRING

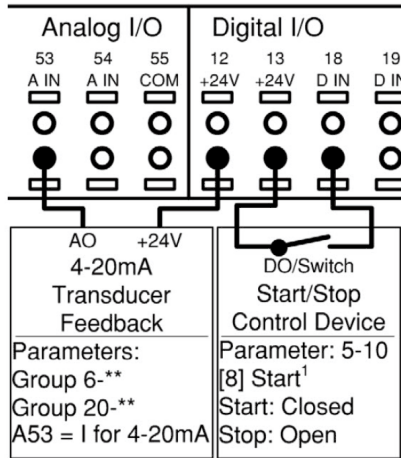

## B&G PART NUMBERS

- S13203 Pressure range: 0-100 psi (0-689 kPa)
- S13204 Pressure range: 0-300 psi (0-2068 kPa)

Consult factory for other ranges.

## INSTALLATION CONSIDERATIONS

- Standard 24 AWG (0.61 mm dia.) 2 wire shielded cable located in a conduit separate from high voltage wiring
- 24 vdc power supplied from Technologic Controller

## DIMENSIONAL INFORMATION

Dimensions in Inches (Millimeters)

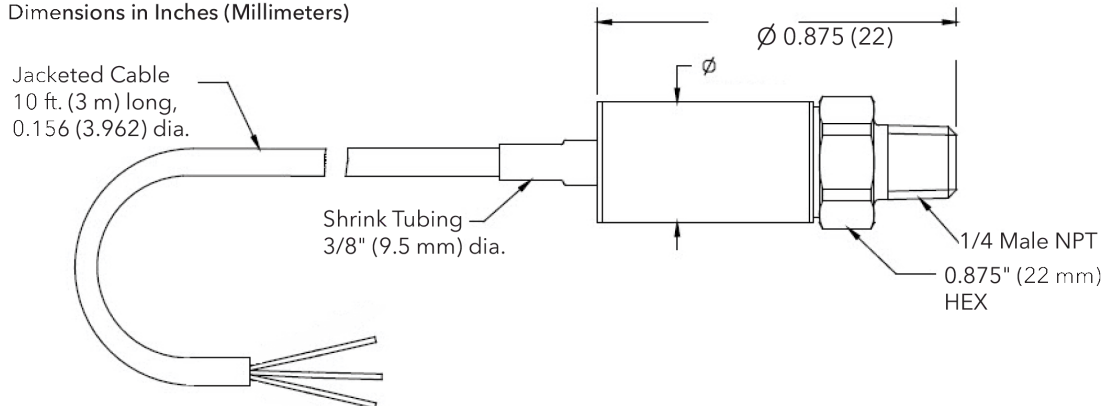



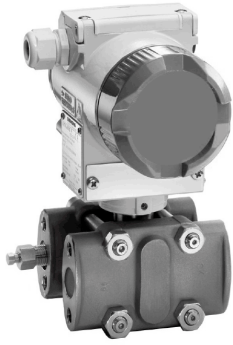

# Differential Pressure Sensor/ Transmitter For Pumps with TECHNOLOGIC® Drives

## FEATURES

- Relays reading to the Technologic controller up to 2000 ft. (610 m) away
- All wetted parts are 316 stainless steel
- Built-in RFI filter effective from 20 to 1000 MHz
- Withstands static pressures up to 2300 PSI (15858 kPa)
- 3 Valve bypass manifold (optional)
- 10 lbs. (4.5 kg) approximate weight

## TECHNOLOGIC ANALOG SENSOR WIRING

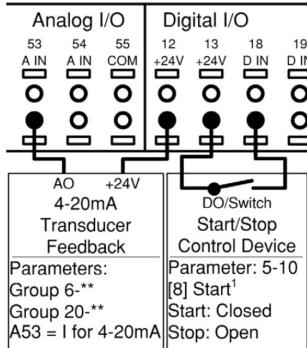

## B&G PART NUMBERS

- S100089 Pressure range: 0 - 40 psi (0 - 276 kPa)
- S100091 Pressure range: 0 - 70 psi (0 - 483 kPa)
- S100092 Pressure range: 0 - 100 psi (0 - 689 kPa)

Consult factory for other ranges.

## INSTALLATION CONSIDERATIONS

- Standard 18 AWG (1.194 mm dia.) 2 wire shielded cable located in a conduit separate from high voltage wiring
- 24 vdc power supplied from Technologic Controller for distance <2000 ft (610 m)

## DIMENSIONAL INFORMATION

Dimensions in Inches (Millimeters)

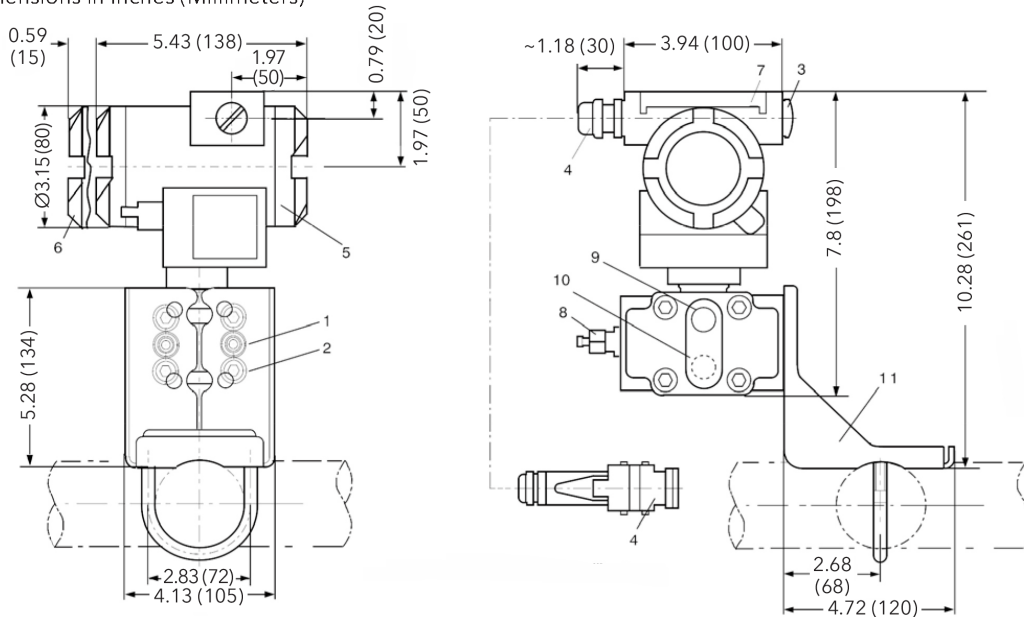

- 1 Process connection 1/4-18NPT for absolute pressure (+) side
- 2 Mounting thread 7/16-20 UNF to EN 61518
- 3 Dummy plug
- 4 Electrical connection: Screwed gland 1/2-14 NPT
- 5 Connection side

- 6 Electronic side, no digital display
- 7 Access cover over magnetic pushbuttons
- 8 Sealing screw with vent shown (optional)
- 9 Side vent for measuring liquid
- 10 Side vent for measuring gas (supplement H02)
- 11 Mounting bracket (2 shackles, 4 nuts, 4 U-plates, 1 angle) made of steel



# Flow Sensor/Transmitter For Pumps with TECHNOLOGIC® Drives

The rugged Bell & Gossett Flow Sensor/Transmitter precisely measures system flow and transmits a proportional 4 to 20 mA DC signal to the Technologic Controller for display or program calculations.

### FEATURES

- Suitable for mounting in vertical pipe
- Suitable for mounting in horizontal pipe within 45° of top dead center
- Non-magnetically sensed, non-fouling paddle wheel
- NEMA 4X Transmitter Enclosure
- Maximum Pressure Ratings:
  - 1000 psi @ 100°F, 900 psi @ 200°F,
  - 750 psi @ 300°F (6895 kPa @ 38°C, 6205 kPa @ 93°C, 5171 kPa @ 149°C)
- Maximum Temperature Ratings:
  - Fluid - 300°F (149°C) continuous service
  - Electronics - 150°F (66°C)
- Optional software and cable available for field programming
- 9.9 lbs (4.5 kg) approximate weight

### DIMENSIONAL INFORMATION

Dimensions in Inches (Millimeters)

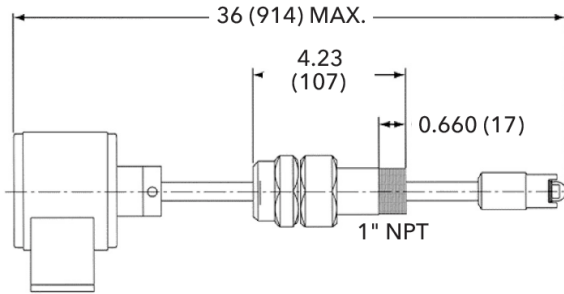

### TECHNOLOGIC ANALOG SENSOR WIRING

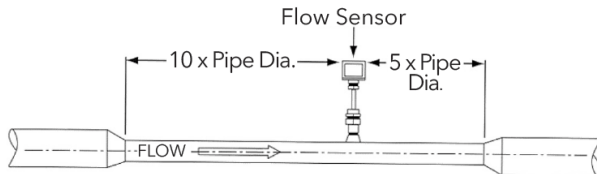
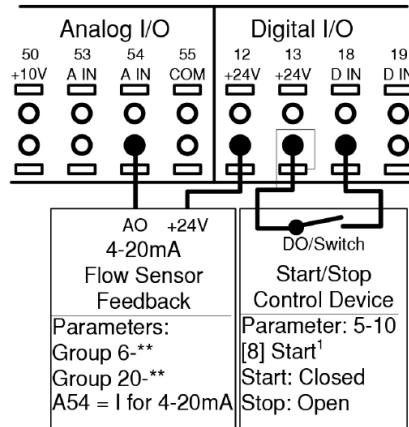

### INSTALLATION CONSIDERATIONS

- Standard 18 AWG (1.194 mm dia.) gauge 3 wire shielded cable located in conduit separate from high voltage wiring
- 24 vdc power supplied from Technologic Controller
- Takes accurate readings and relays them to the Technologic Controller up to 2,000 ft. (610 m) away, when 10 pipe diameters upstream and 5 pipe diameters downstream of straight uninterrupted flow is present.

CALIBRATION CHART		
B&G Part No.	Pipe Size	Max. Flow
137411	3" Sch 40	250 gpm (16 l/sec)
137412	4" Sch 40	400 gpm (25 l/sec)
137413	6" Sch 40	850 gpm (54 l/sec)
137414	8" Sch 40	1750 gpm (110 l/sec)
137415	10" Sch 40	3150 gpm (199 l/sec)
137416	12" Sch 40	5000 gpm (315 l/sec)
137417	14" Sch 40	6400 gpm (404 l/sec)
137418	16" Sch 40	9100 gpm (574 l/sec)
137419	18" Sch 40	12400 gpm (782 l/sec)
137420	20" Sch 40	16500 gpm (1041 l/sec)

Consult factory for custom flow range calibration.