

| | | |
|---|--|--|
| JOB: UNIT TAG: ENGINEER: CONTRACTOR: | REPRESENTATIVE: ORDER NO.: SUBMITTED BY: APPROVED BY: | DATE: DATE: DATE: |
|---|--|--|

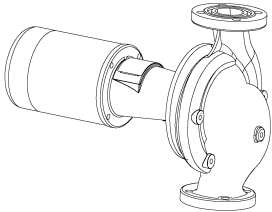

1 1/2 x 1 1/2 x 7

Series 60[®]

Maintenance Free In-Line Mounted Pump

SPECIFICATIONS

FLOW _____ HEAD _____
 HP _____ RPM _____
 VOLTS _____
 CYCLE _____ PHASE _____
 ENCLOSURE _____
 APPROX. WEIGHT _____
 SPECIALS _____

MATERIALS OF CONSTRUCTION

BRONZE FITTED ALL BRONZE

FEATURES

- MAINTENANCE FREE PUMP
- INTERNALLY SELF-FLUSHING MECHANICAL SEAL
- XLII[®] LUBRICATION SYSTEM
- THREE YEAR WARRANTY
- FACTORY TEST

WORKING PRESSURE

- 175 psi (12 bar) W.P.

TYPE OF SEAL

- BUNA/CARBON-CERAMIC (STANDARD) (-20 °F TO 225 °F)

TYPE OF SEAL

- EPT/TUNGSTEN-CARBIDE (-20 °F TO 250 °F)

TYPE OF SEAL

- VITON/CARBON-CERAMIC (0 °F TO 225 °F)

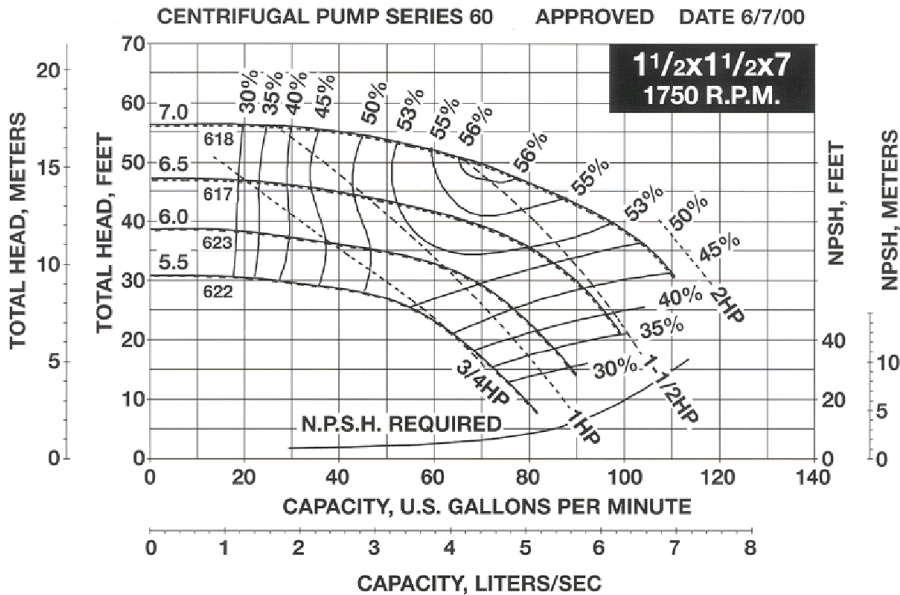

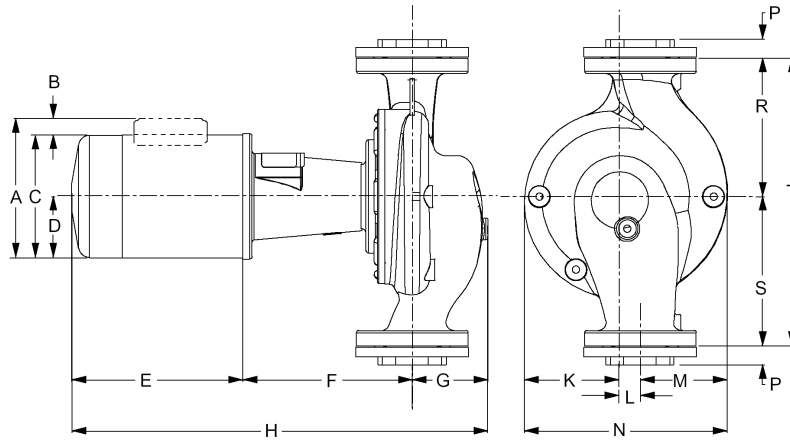

| SUCTION AND DISCHARGE SIZE INCHES NPT | PUMP DIMENSIONS IN INCHES (MM) | | | | | | | | | |
|--|--------------------------------|---------------|----------------|-----------|---------------|----------------|-------------|----------------|------------|-----------------|
| | F | G | K | L | M | N | P | R | S | T |
| 1-1/2 | 9-3/8 (238) | 3-1/4 (83) | 4-5/8 (117) | 1 (25) | 3-7/8 (98) | 9-1/2 (241) | 3/4 (19) | 6-1/2 (165) | 7 (178) | 13-1/2 (343) |

MAXIMUM WORKING PRESSURE 175PSI (12 BAR)

ALL MOTORS 1750 RPM

DIMENSIONS - Inches (mm)

| MOTOR HP | | MOTOR DIMENSIONS - INCHES (MM) | | | | | |
|----------|-------|--------------------------------|---------------|----------------|----------------|-----------------|-----------------|
| HP | PHASE | A | B | C | D | E | H |
| 3/4 | 1 | 10-1/8 (257) | 2-1/4 (57) | 7-7/8 (200) | 4-3/8 (111) | 11 (279) | 23-5/8 (600) |
| 3/4 | 3 | 7-7/8 (200) | - | 7-7/8 (200) | 4-3/8 (111) | 11 (279) | 23-5/8 (600) |
| 1 | 1 | 10-1/8 (257) | 2-1/4 (57) | 7-7/8 (200) | 4-3/4 (121) | 11 (279) | 23-5/8 (600) |
| 1 | 3 | 7-7/8 (200) | - | 7-7/8 (200) | 4-3/4 (121) | 11 (279) | 23-5/8 (600) |
| 1-1/2 | 1 | 8-3/4 (222) | 2-1/4 (57) | 6-1/2 (165) | 3-1/4 (83) | 10-3/4 (273) | 21-5/8 (549) |
| 1-1/2 | 3 | 6-1/2 (165) | - | 6-1/2 (165) | 3-1/4 (83) | 10-3/4 (273) | 21-5/8 (549) |
| 2 | 3 | 6-1/2 (165) | - | 6-1/2 (165) | 3-1/4 (83) | 10-3/4 (273) | 21-3/8 (543) |

Dimensions are subject to change. Not to be used for construction purposes unless certified.
Includes Companion Flanges.

Xylem Inc.
8200 N. Austin Avenue
Morton Grove, IL 60053
Phone: (847)966-3700
Fax: (847)965-8379
www.bellgossett.com

