

JOB:	REPRESENTATIVE:	
UNIT TAG:	ORDER NO.	DATE:
ENGINEER:	SUBMITTED BY:	DATE:
CONTRACTOR:	APPROVED BY:	DATE:

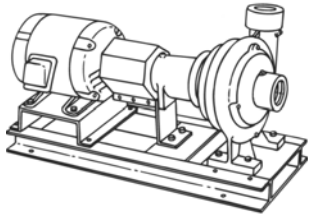

# 1.5BC

## Series e-1510

### Centrifugal Pumps - Base Mounted

**SPECIFICATIONS**

FLOW \_\_\_\_\_ HEAD \_\_\_\_\_

HP \_\_\_\_\_ RPM \_\_\_\_\_

VOLTS \_\_\_\_\_

CYCLE \_\_\_\_\_ PHASE \_\_\_\_\_

ENCLOSURE \_\_\_\_\_

APPROX. WEIGHT \_\_\_\_\_

SPECIALS \_\_\_\_\_

**MATERIALS OF CONSTRUCTION**

Stainless Steel Fitted

**FEATURES**

- i-ALERT™ Condition Monitor
- ANSI/OSHA Coupling Guard
- Center Drop Out Spacer Coupling
- Fabricated Heavy Duty Baseplate

**MAXIMUM WORKING PRESSURE**

175 psi (12 bar) W.P.

**TYPE OF SEAL**

- Standard Seal (Buna-Carbon/Ceramic)
- F Standard Seal w/ Flush Line (Buna-Carbon/Ceramic)
- S Stuffing Box Construction w/ Flushed Mechanical Single Seal (EPR-Tungsten Carbide/Carbon)
- PF Stuffing Box Construction w/ Packing (Graphite Impregnated Teflon)

**Note: Equipped with NEOPRENE coupling**

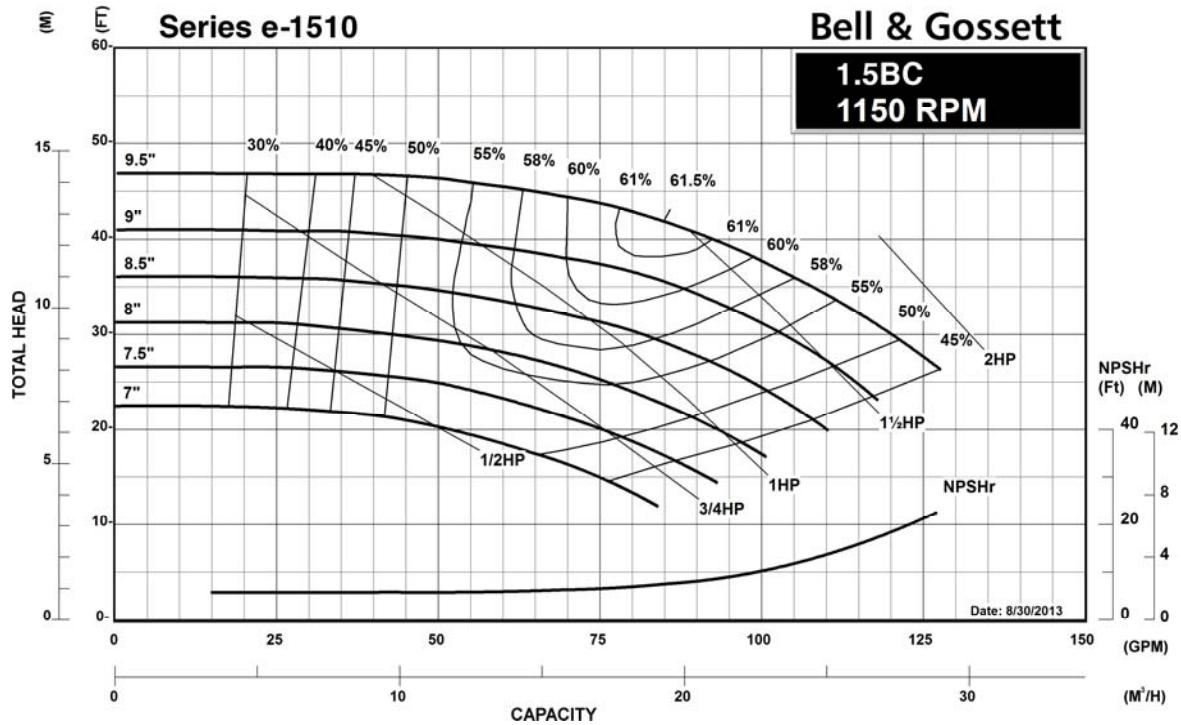

JOB: _____  UNIT TAG: _____ ENGINEER: _____ CONTRACTOR: _____	REPRESENTATIVE: _____  ORDER NO. _____ SUBMITTED BY: _____ APPROVED BY: _____	DATE: _____ DATE: _____ DATE: _____
---	---	---

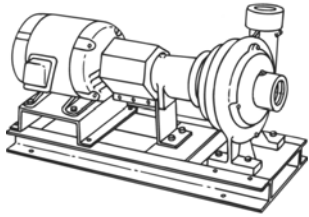

# 1.5BC

## Series e-1510

### Centrifugal Pumps - Base Mounted

**SPECIFICATIONS**

FLOW \_\_\_\_\_ HEAD \_\_\_\_\_  
 HP \_\_\_\_\_ RPM \_\_\_\_\_  
 VOLTS \_\_\_\_\_  
 CYCLE \_\_\_\_\_ PHASE \_\_\_\_\_  
 ENCLOSURE \_\_\_\_\_  
 APPROX. WEIGHT \_\_\_\_\_  
 SPECIALS \_\_\_\_\_

**MATERIALS OF CONSTRUCTION**

Stainless Steel Fitted

**FEATURES**

- i-ALERT™ Condition Monitor
- ANSI/OSHA Coupling Guard
- Center Drop Out Spacer Coupling
- Fabricated Heavy Duty Baseplate

**MAXIMUM WORKING PRESSURE**

175 psi (12 bar) W.P.

**TYPE OF SEAL**

- Standard Seal (Buna-Carbon/Ceramic)
- F Standard Seal w/ Flush Line (Buna-Carbon/Ceramic)
- S Stuffing Box Construction w/ Flushed Mechanical Single Seal (EPR-Tungsten Carbide/Carbon)
- PF Stuffing Box Construction w/ Packing (Graphite Impregnated Teflon)

**Note: Equipped with NEOPRENE coupling**

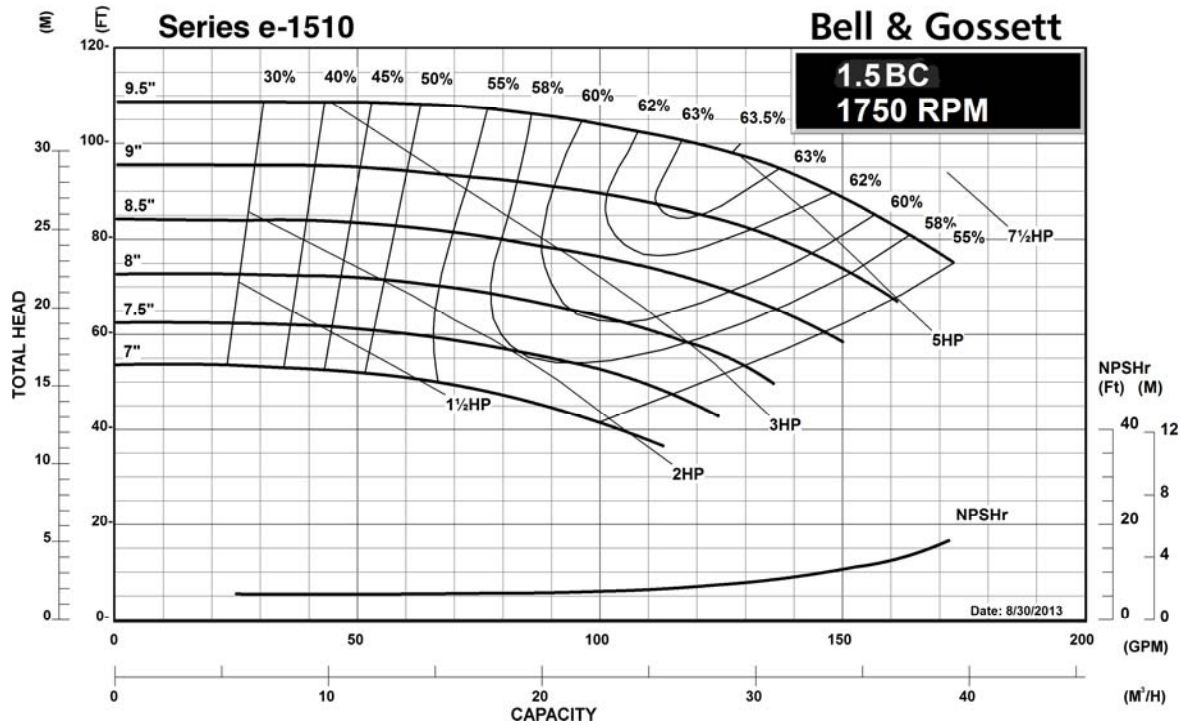

JOB:	REPRESENTATIVE:	
UNIT TAG:	ORDER NO.	DATE:
ENGINEER:	SUBMITTED BY:	DATE:
CONTRACTOR:	APPROVED BY:	DATE:

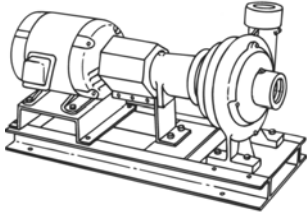

# 1.5BC Series e-1510 Centrifugal Pumps - Base Mounted

**SPECIFICATIONS**

FLOW \_\_\_\_\_ HEAD \_\_\_\_\_  
 HP \_\_\_\_\_ RPM \_\_\_\_\_  
 VOLTS \_\_\_\_\_  
 CYCLE \_\_\_\_\_ PHASE \_\_\_\_\_  
 ENCLOSURE \_\_\_\_\_  
 APPROX. WEIGHT \_\_\_\_\_  
 SPECIALS \_\_\_\_\_

**MATERIALS OF CONSTRUCTION**

Stainless Steel Fitted

**FEATURES**

- i-ALERT™ Condition Monitor
- ANSI/OSHA Coupling Guard
- Center Drop Out Spacer Coupling
- Fabricated Heavy Duty Baseplate

**MAXIMUM WORKING PRESSURE**

175 psi (12 bar) W.P.

**TYPE OF SEAL**

- Standard Seal (Buna-Carbon/Ceramic)
- F Standard Seal w/ Flush Line (Buna-Carbon/Ceramic)
- S Stuffing Box Construction w/ Flushed Mechanical Single Seal (EPR-Tungsten Carbide/Carbon)
- PF Stuffing Box Construction w/ Packing (Graphite Impregnated Teflon)

**Note: Equipped with NEOPRENE coupling**

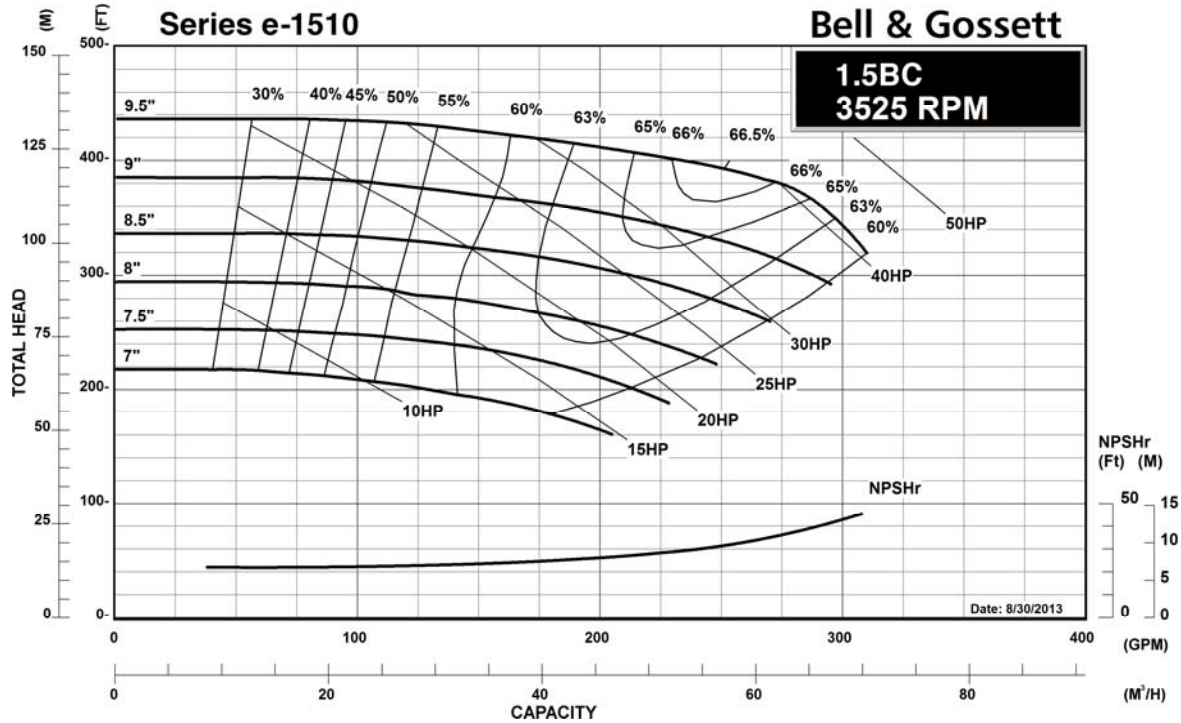

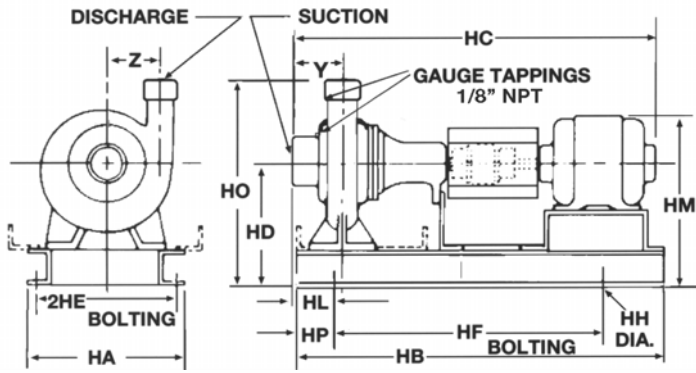

NOZZLE SIZES	
Discharge	1-1/2" N.P.T.
Suction	2" N.P.T.

**DIMENSIONS – Inches (mm)**

**STANDARD SEAL**

MOTOR FRAME	HA	HB	HC MAX	HD	2HE	HF <sub>1</sub>	HF <sub>2</sub>	HH	HL	HM MAX	HO	HP	Y	Z
<b>"S" FRAME</b>														
143T	14-5/8 (371)	31 (787)	28-3/8 (721)	10-3/4 (273)	12-7/8 (327)	25 (635)	-	3/4 (19)	1-11/16 (43)	14-1/2 (368)	17-1/4 (438)	3 (76)	3-1/8 (79)	5-3/4 (146)
145T	14-5/8 (371)	31 (787)	29-3/8 (746)	10-3/4 (273)	12-7/8 (327)	25 (635)	-	3/4 (19)	1-11/16 (43)	14-1/2 (368)	17-1/4 (438)	3 (76)	3-1/8 (79)	5-3/4 (146)
182T	14-5/8 (371)	31 (787)	32-1/8 (816)	10-3/4 (273)	12-7/8 (327)	25 (635)	-	3/4 (19)	1-11/16 (43)	16 (406)	17-1/4 (438)	3 (76)	3-1/8 (79)	5-3/4 (146)
184T	14-5/8 (371)	31 (787)	32-7/8 (835)	10-3/4 (273)	12-7/8 (327)	25 (635)	-	3/4 (19)	1-11/16 (43)	16 (406)	17-1/4 (438)	3 (76)	3-1/8 (79)	5-3/4 (146)
213T 1750 RPM	14-5/8 (371)	34-5/8 (879)	36-7/8 (937)	10-3/4 (273)	12-7/8 (327)	28-5/8 (727)	-	3/4 (19)	1-11/16 (43)	16-5/8 (422)	17-1/4 (438)	3 (76)	3-1/8 (79)	5-3/4 (146)
215T 1750 RPM	14-5/8 (371)	34-5/8 (879)	36-7/8 (937)	10-3/4 (273)	12-7/8 (327)	28-5/8 (727)	-	3/4 (19)	1-11/16 (43)	16-5/8 (422)	17-1/4 (438)	3 (76)	3-1/8 (79)	5-3/4 (146)
<b>"L" FRAME</b>														
213T 3500 RPM	14-5/8 (371)	39-3/8 (1000)	41-1/4 (1048)	10-3/4 (273)	12-7/8 (327)	33-3/8 (848)	-	3/4 (19)	1-11/16 (43)	16-5/8 (422)	17-1/4 (438)	3 (76)	3-1/8 (79)	5-3/4 (146)
215T 3500 RPM	14-5/8 (371)	39-3/8 (1000)	41-1/4 (1048)	10-3/4 (273)	12-7/8 (327)	33-3/8 (848)	-	3/4 (19)	1-11/16 (43)	16-5/8 (422)	17-1/4 (438)	3 (76)	3-1/8 (79)	5-3/4 (146)
254T	16 (406)	46-1/2 (1181)	45 (1143)	12 (305)	14 (356)	36-1/2 (927)	18-1/4 (464)	7/8 (22)	2-13/16 (71)	18-7/8 (479)	18-1/2 (470)	5 (127)	3-1/8 (79)	5-3/4 (146)
256T	16 (406)	46-1/2 (1181)	45 (1143)	12 (305)	14 (356)	36-1/2 (927)	18-1/4 (464)	7/8 (22)	2-13/16 (71)	18-7/8 (479)	18-1/2 (470)	5 (127)	3-1/8 (79)	5-3/4 (146)
284TS	16 (406)	46-1/2 (1181)	46-3/4 (1187)	12 (305)	14 (356)	36-1/2 (927)	18-1/4 (464)	7/8 (22)	2-13/16 (71)	18-7/8 (479)	18-1/2 (470)	5 (127)	3-1/8 (79)	5-3/4 (146)
286TS	16 (406)	46-1/2 (1181)	46-1/8 (1172)	13 (330)	14 (356)	36-1/2 (927)	18-1/4 (464)	7/8 (22)	2-13/16 (71)	21 (533)	19-1/2 (495)	5 (127)	3-1/8 (79)	5-3/4 (146)
324TS	16 (406)	46-1/2 (1181)	47-5/8 (1210)	13 (330)	14 (356)	36-1/2 (927)	18-1/4 (464)	7/8 (22)	2-13/16 (71)	21 (533)	19-1/2 (495)	5 (127)	3-1/8 (79)	5-3/4 (146)
326TS	16 (406)	46-1/2 (1181)	49-5/8 (1260)	12 (305)	14 (356)	36-1/2 (927)	18-1/4 (464)	7/8 (22)	2-13/16 (71)	21-1/8 (537)	18-1/2 (470)	5 (127)	3-1/8 (79)	5-3/4 (146)

**STUFFING BOX**

MOTOR FRAME	HA	HB	HC MAX	HD	2HE	HF <sub>1</sub>	HF <sub>2</sub>	HH	HL	HM MAX	HO	HP	Y	Z
<b>"S" FRAME</b>														
143T	14-5/8 (371)	34-5/8 (879)	32 (813)	10-3/4 (273)	12-7/8 (327)	28-5/8 (727)	-	3/4 (19)	1-11/16 (43)	14-1/2 (368)	17-1/4 (438)	3 (76)	3-1/8 (79)	5-3/4 (146)
145T	14-5/8 (371)	34-5/8 (879)	33 (838)	10-3/4 (273)	12-7/8 (327)	28-5/8 (727)	-	3/4 (19)	1-11/16 (43)	14-1/2 (368)	17-1/4 (438)	3 (76)	3-1/8 (79)	5-3/4 (146)
182T	14-5/8 (371)	34-5/8 (879)	35-3/4 (908)	10-3/4 (273)	12-7/8 (327)	28-5/8 (727)	-	3/4 (19)	1-11/16 (43)	16 (406)	17-1/4 (438)	3 (76)	3-1/8 (79)	5-3/4 (146)
184T	14-5/8 (371)	34-5/8 (879)	36-1/2 (927)	10-3/4 (273)	12-7/8 (327)	28-5/8 (727)	-	3/4 (19)	1-11/16 (43)	16 (406)	17-1/4 (438)	3 (76)	3-1/8 (79)	5-3/4 (146)
213T 1750 RPM	14-5/8 (371)	39-3/8 (1000)	40-1/2 (1029)	10-3/4 (273)	12-7/8 (327)	33-3/8 (848)	-	3/4 (19)	1-11/16 (43)	16-5/8 (422)	17-1/4 (438)	3 (76)	3-1/8 (79)	5-3/4 (146)
215T 1750 RPM	14-5/8 (371)	39-3/8 (1000)	40-1/2 (1029)	10-3/4 (273)	12-7/8 (327)	33-3/8 (848)	-	3/4 (19)	1-11/16 (43)	16-5/8 (422)	17-1/4 (438)	3 (76)	3-1/8 (79)	5-3/4 (146)
<b>"L" FRAME</b>														
213T 3500 RPM	16 (406)	46-1/2 (1181)	43-3/4 (111)	12 (305)	14 (356)	36-1/2 (927)	18-1/4 (464)	7/8 (22)	2-13/16 (71)	17-7/8 (454)	18-1/2 (470)	5 (127)	3-1/8 (79)	5-3/4 (146)
215T 3500 RPM	16 (406)	46-1/2 (1181)	43-3/4 (111)	12 (305)	14 (356)	36-1/2 (927)	18-1/4 (464)	7/8 (22)	2-13/16 (71)	17-7/8 (454)	18-1/2 (470)	5 (127)	3-1/8 (79)	5-3/4 (146)
254T	16 (406)	46-1/2 (1181)	43-3/4 (1111)	12 (305)	14 (356)	36-1/2 (927)	18-1/4 (464)	7/8 (22)	2-13/16 (71)	17-7/8 (454)	18-1/2 (470)	5 (127)	3-1/8 (79)	5-3/4 (146)
256T	16 (406)	51-3/4 (1314)	47-1/2 (1207)	12 (305)	14 (356)	41-3/4 (1060)	20-7/8 (530)	7/8 (22)	2-13/16 (71)	18-7/8 (479)	18-1/2 (470)	5 (127)	3-1/8 (79)	5-3/4 (146)
284TS	16 (406)	51-3/4 (1314)	49-1/4 (1251)	12 (305)	14 (356)	41-3/4 (1060)	20-7/8 (530)	7/8 (22)	2-13/16 (71)	18-7/8 (479)	18-1/2 (470)	5 (127)	3-1/8 (79)	5-3/4 (146)
286TS	16 (406)	51-3/4 (1314)	48-1/2 (1232)	13 (330)	14 (356)	41-3/4 (1060)	20-7/8 (530)	7/8 (22)	2-13/16 (71)	21 (533)	19-1/2 (495)	5 (127)	3-1/8 (79)	5-3/4 (146)
324TS	16 (406)	51-3/4 (1314)	50 (1270)	13 (330)	14 (356)	41-3/4 (1060)	20-7/8 (530)	7/8 (22)	2-13/16 (71)	21 (533)	19-1/2 (495)	5 (127)	3-1/8 (79)	5-3/4 (146)
326TS	16 (406)	51-3/4 (1314)	52 (1321)	12 (305)	14 (356)	41-3/4 (1060)	20-7/8 (530)	7/8 (22)	2-13/16 (71)	21-1/8 (537)	18-1/2 (470)	5 (127)	3-1/8 (79)	5-3/4 (146)

Dimensions are subject to change. Not to be used for construction purposes unless certified.

Xylem Inc.  
8200 N. Austin Avenue  
Morton Grove, IL 60053  
Phone: (847)966-3700  
Fax: (847)965-8379  
www.xylem.com/brands/bellgossett

