

<p>JOB:</p> <p>UNIT TAG:</p> <p>ENGINEER:</p> <p>CONTRACTOR:</p>	<p>REPRESENTATIVE:</p> <p>ORDER NO.</p> <p>SUBMITTED BY:</p> <p>APPROVED BY:</p>	<p>DATE:</p> <p>DATE:</p> <p>DATE:</p>
---	---	---

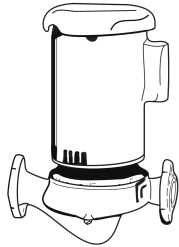

1 1/2 AA

Series "90"

Centrifugal Pumps
Vertical In-Line Mounted - Close Coupled

SPECIFICATIONS

FLOW _____ HEAD _____

HP _____ RPM _____

VOLTS _____

CYCLE _____ PHASE _____

ENCLOSURE _____

APPROX. WEIGHT _____

SPECIALS _____

MATERIALS OF CONSTRUCTION

BRONZE FITTED ALL BRONZE

MAXIMUM WORKING PRESSURE

175 psi (12 bar) W.P.

TYPE OF SEAL

90 Standard Seal
(Buna-Carbon/Ceramic)

Optional Seal
(EPR Carbon/Tungsten Carbide)

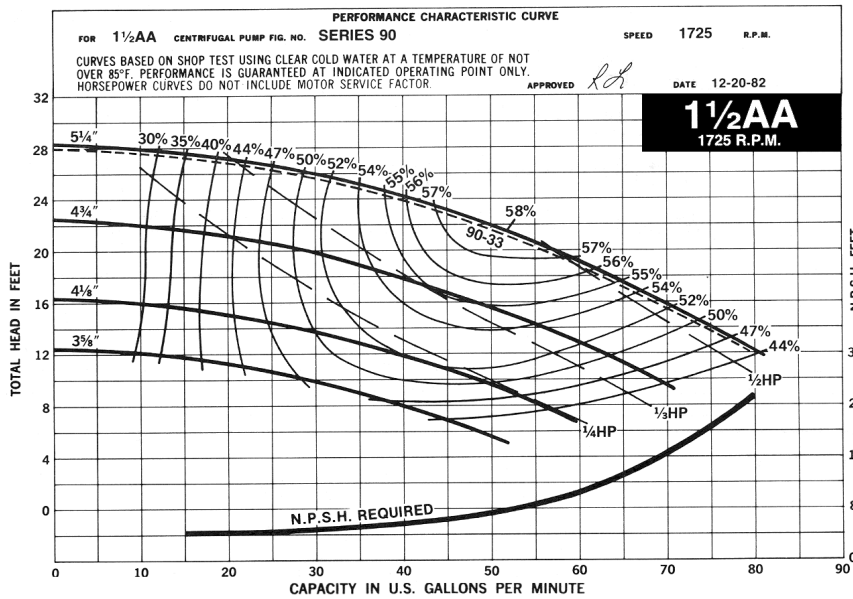

<p>JOB: _____</p> <p>UNIT TAG: _____</p> <p>ENGINEER: _____</p> <p>CONTRACTOR: _____</p>	<p>REPRESENTATIVE: _____</p> <p>ORDER NO. _____</p> <p>SUBMITTED BY: _____</p> <p>APPROVED BY: _____</p> <p>DATE: _____</p> <p>DATE: _____</p> <p>DATE: _____</p>
--	---

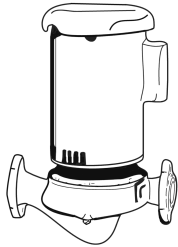

1 1/2 AA

Series "90"

Centrifugal Pumps
Vertical In-Line Mounted - Close Coupled

SPECIFICATIONS

FLOW _____ HEAD _____

HP _____ RPM _____

VOLTS _____

CYCLE _____ PHASE _____

ENCLOSURE _____

APPROX. WEIGHT _____

SPECIALS _____

MATERIALS OF CONSTRUCTION

BRONZE FITTED ALL BRONZE

MAXIMUM WORKING PRESSURE

175 psi (12 bar) W.P.

TYPE OF SEAL

90 Standard Seal
(Buna-Carbon/Ceramic)

Optional Seal
(EPR Carbon/Tungsten Carbide)

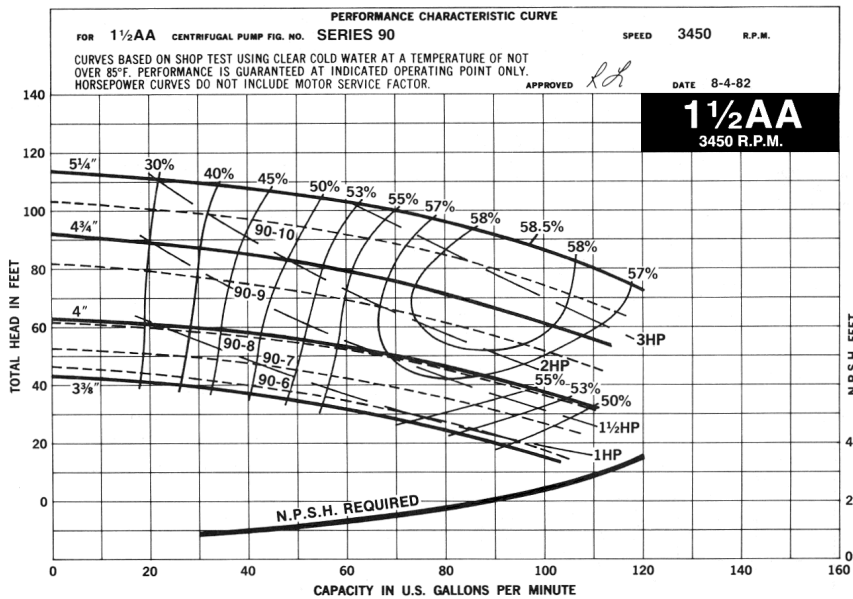

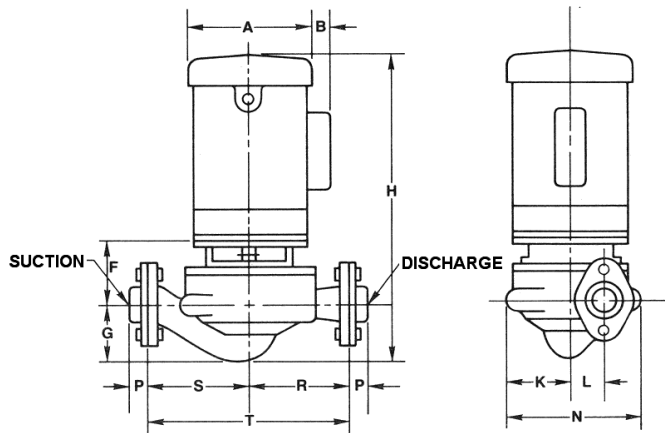

Companion Flanges furnished for Suction and Discharge

PUMP SIZE	SUCTION AND DISCHARGE SIZE - INCHES NPT	PUMP DIMENSIONS IN INCHES (MM)								
		F	G	K	L	N	P	R	S	T
1-1/2AA	1-1/2 (38)	2-7/8 (73)	3-7/8 (98)	3-3/4 (95)	1-3/8 (35)	7-7/8 (200)	3/4 (19)	5 (127)	6-1/2 (165)	11-1/2 (292)

MAXIMUM WORKING PRESSURE 175PSI (12 BAR)

DIMENSIONS – Inches (mm)

MOTOR HP			A MAX.	B	H MAX.
1725	3450	PHASE			
1/4	-	1	7-1/2 (190)	1-1/2 (38)	15-7/8 (403)
1/4	-	3	7-1/2 (190)	-	14-7/8 (378)
1/3	-	1	7-1/2 (190)	1-1/2 (38)	16-1/4 (413)
1/3	-	3	7-1/2 (190)	-	15-3/4 (400)
1/2	-	1	7-1/2 (190)	1-1/2 (38)	16-1/4 (413)
1/2	-	3	7-1/2 (190)	-	15-3/4 (400)
3/4	-	1	7-1/2 (190)	1-1/2 (38)	17-1/4 (438)
3/4	-	3	7-1/2 (190)	-	16-3/4 (425)
-	3/4	1	7-1/2 (190)	1-1/2 (38)	16-1/4 (413)
-	3/4	3	7-1/2 (190)	-	15-7/8 (403)
-	1	1	7-1/2 (190)	1-1/2 (38)	16-3/4 (425)
-	1	3	7-1/2 (190)	-	16-1/2 (419)
-	1-1/2	1	7-1/2 (190)	1-1/2 (38)	18 (457)
-	1-1/2	3	7-1/2 (190)	-	17-1/2 (444)
-	2	3	7-1/2 (190)	-	17-1/2 (444)
-	3	3	7-1/2 (190)	-	18 (457)
-	5	3	7-1/2 (190)	-	19-1/2 (495)

Dimensions are subject to change. Not to be used for construction purposes unless certified.

Xylem Inc.
 8200 N. Austin Avenue
 Morton Grove, IL 60053
 Phone: (847)966-3700
 Fax: (847)965-8379
 www.bellgossett.com

