

JOB: UNIT TAG: ENGINEER: CONTRACTOR:	REPRESENTATIVE: ORDER NO. SUBMITTED BY: APPROVED BY:	DATE: DATE: DATE:
---	---	--

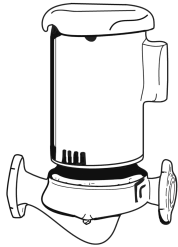

1-1/4AA

Series "90"

Centrifugal Pumps
Vertical In-Line Mounted - Close Coupled

SPECIFICATIONS

FLOW _____ HEAD _____
 HP _____ RPM _____
 VOLTS _____
 CYCLE _____ PHASE _____
 ENCLOSURE _____
 APPROX. WEIGHT _____
 SPECIALS _____

MATERIALS OF CONSTRUCTION

BRONZE FITTED ALL BRONZE

MAXIMUM WORKING PRESSURE

175 psi (12 bar) W.P.

TYPE OF SEAL

90 Standard Seal
(Buna-Carbon/Ceramic)
 Optional Seal
(EPR Carbon/Tungsten Carbide)

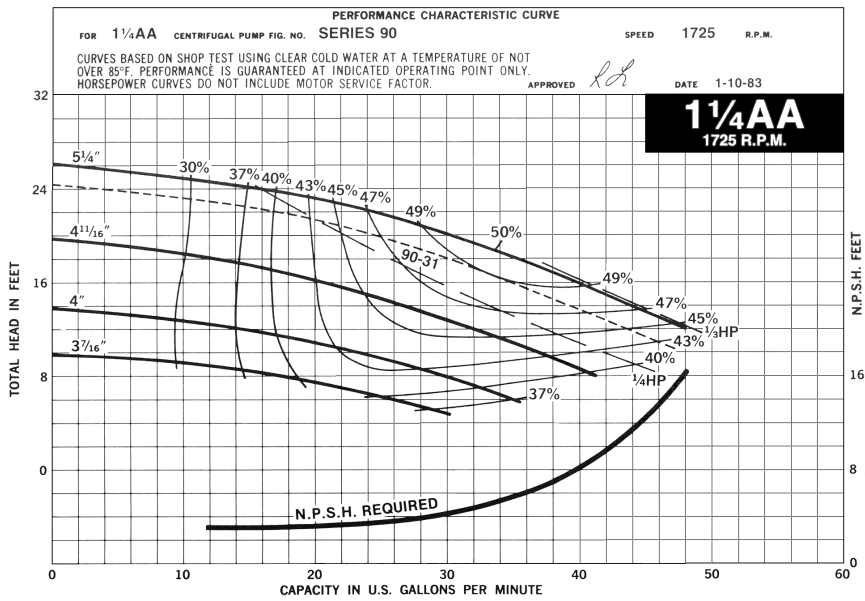

<p>JOB:</p> <p>UNIT TAG:</p> <p>ENGINEER:</p> <p>CONTRACTOR:</p>	<p>REPRESENTATIVE:</p> <p>ORDER NO.</p> <p>SUBMITTED BY:</p> <p>APPROVED BY:</p>	<p>DATE:</p> <p>DATE:</p> <p>DATE:</p>
---	---	---

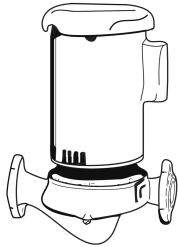

1-1/4AA

Series "90"

Centrifugal Pumps

Vertical In-Line Mounted - Close Coupled

SPECIFICATIONS

FLOW _____ HEAD _____

HP _____ RPM _____

VOLTS _____

CYCLE _____ PHASE _____

ENCLOSURE _____

APPROX. WEIGHT _____

SPECIALS _____

MATERIALS OF CONSTRUCTION

BRONZE FITTED ALL BRONZE

MAXIMUM WORKING PRESSURE

175 psi (12 bar) W.P.

TYPE OF SEAL

90 Standard Seal
(Buna-Carbon/Ceramic)

Optional Seal
(EPR Carbon/Tungsten Carbide)

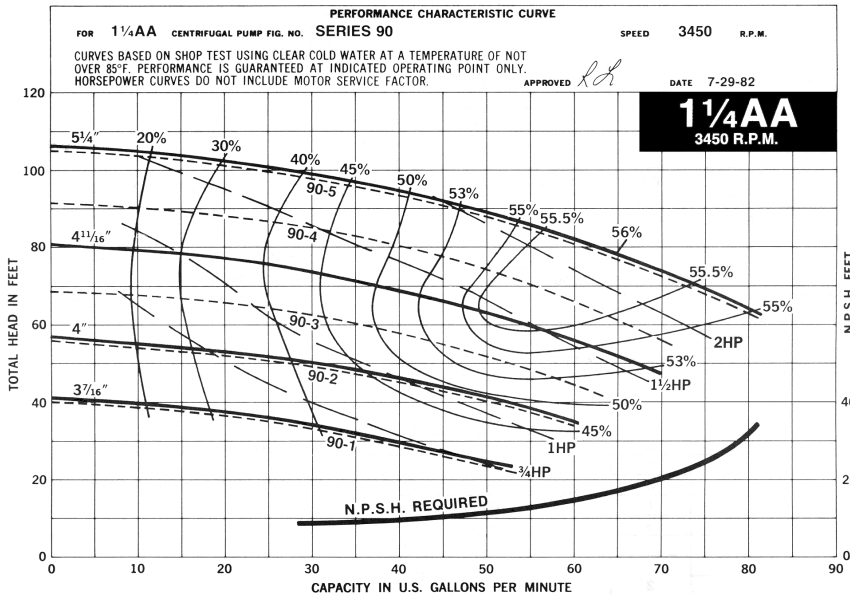

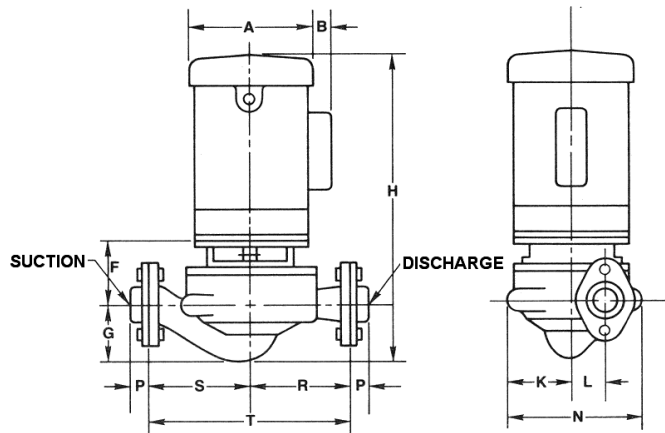

Companion Flanges furnished for Suction and Discharge

PUMP SIZE	SUCTION AND DISCHARGE SIZE - INCHES NPT	PUMP DIMENSIONS IN INCHES (MM)								
		F	G	K	L	N	P	R	S	T
1-1/4AA	1-1/4	2-3/4 (70)	3-11/16 (94)	3-5/8 (92)	1-3/8 (35)	7-1/2 (190)	3/4 (19)	5 (127)	6 (152)	11 (279)

MAXIMUM WORKING PRESSURE 175PSI (12 BAR)

DIMENSIONS - Inches (mm)

MOTOR HP			A MAX.	B	H MAX.
1725	3450	PHASE			
1/4		1	7-1/2 (190)	1-1/2 (38)	15-1/2 (394)
1/4		3	7-1/2 (190)		14-1/2 (368)
1/3		1	7-1/2 (190)	1-1/2 (38)	16 (406)
1/3		3	7-1/2 (190)		15-1/2 (394)
	3/4	1	7-1/2 (190)	1-1/2 (38)	16 (406)
	3/4	3	7-1/2 (190)		15-5/8 (397)
	1	1	7-1/2 (190)	1-1/2 (38)	16-1/2 (419)
	1	3	7-1/2 (190)		16-1/4 (413)
	1-1/2	1	7-1/2 (190)	1-1/2 (38)	17-3/4 (451)
	1-1/2	3	7-1/2 (190)		17-1/4 (438)
	2	3	7-1/2 (190)		17-1/4 (438)
	3	3	7-1/2 (190)		17-3/4 (451)

Dimensions are subject to change. Not to be used for construction purposes unless certified.

Xylem Inc.
 8200 N. Austin Avenue
 Morton Grove, IL 60053
 Phone: (847)966-3700
 Fax: (847)965-8379
 www.bellgossett.com

