

# Performance curves

UPS 80-80/4  
3 phase 208-230 V, 60 Hz

## Performance curves

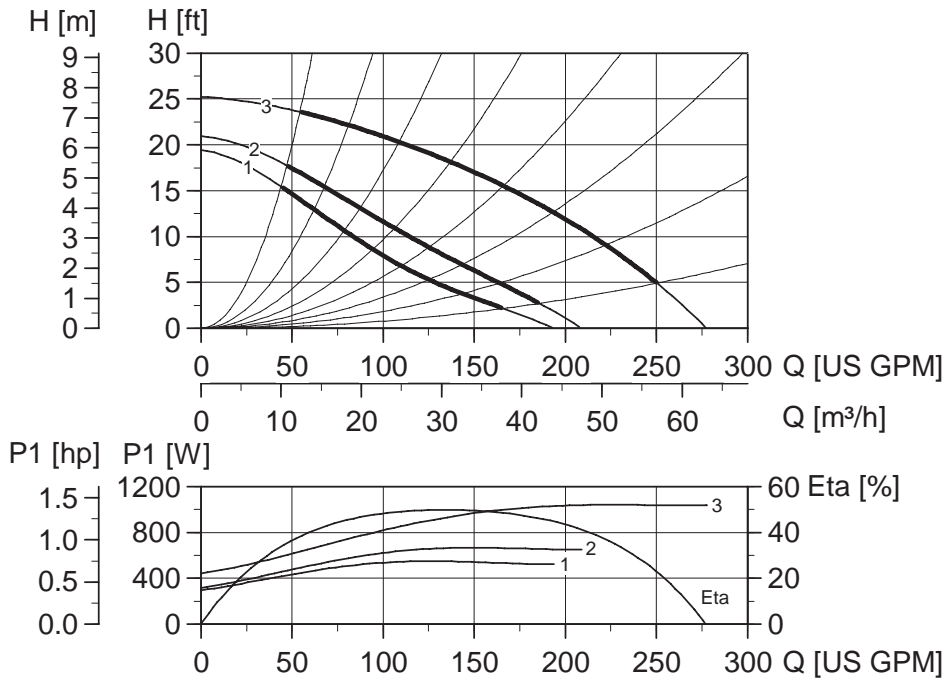

Note: ETA is calculated as wire-to-water efficiency.

## Weights and volume

	Cast Iron				Bronze			
	lbs.	ft <sup>3</sup>	Kg	m <sup>3</sup>	lbs.	ft <sup>3</sup>	Kg	m <sup>3</sup>
Net weight	89.7		40.7		102.3		46.4	
Gross weight	102.1		46.3		114.6		52	
Shipping volume		2.90		0.082		2.90		0.082

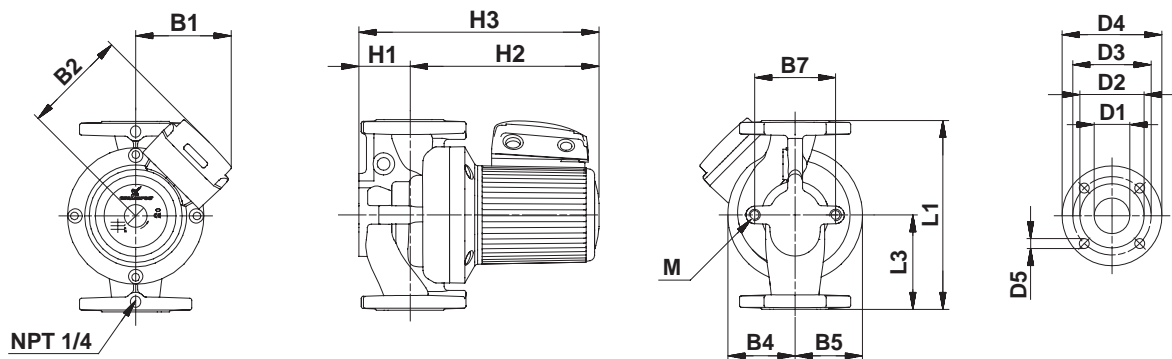

## Dimensions

	L1	L3	B1	B2	B4	B5	B7	H1	H2	H3	D1	D2	D3	D4	D5	M
[Inches]	19	9 1/2	5 3/4	6 11/16	4 15/16	3 15/16	6 5/16	3 13/16	11 1/4	15 1/16	3 3/16	5	6	7 9/16	3/4	
[mm]	482.6	241.3	145	169	125	100	160	97	285	387	80.8	127	152	191	19	M16